

AC SERVOMOTORS/SERVO DRIVES

G5-series

Pulse-train Input Type

User's Manual

R88D-KE□(AC Servomotors)

R88M-KP□(AC Servo Drives)



To: All Customers

Corrections Insert

OMRON Corporation

Cat. No. I584-E1-02

Thank you for supporting OMRON and OMRON products.

Some mistakes were discovered in the manual listed below. We sincerely apologize for these mistakes.

Please mark your manual so that the corrections are noted on the pages concerned, and then securely add any required pages from this *Notification* to the rear of the manual.

Applicable Manuals

This Notification applies to the following manuals: AC SERVOMOTORS/SERVO DRIVES G5-series Pulse-tr1in Input Type USER'S MANUAL (Cat.I584-E1-02).

Relevant Location: Decelerator Dimensions

1 Page 2-52

For 1,000-r/min Servomotors (900 W to 3 kW)



The frames show the locations of the additions and changes.

Current Contents

● For 1,000-r/min Servomotors (900 W to 3 kW)

Model	Outline drawing	Dimensions [mm]													
		LM	LR	C1	C2	D1	D2	D3	D4	D5	E	F1	F2		
900 W	1/5	R88G-HPG32A05900TB□	1	129	133	120	□130	135	145	115	114	84	98	12.5	35
	1/11	R88G-HPG32A11900TB□	1	129	133	120	□130	135	145	115	114	84	98	12.5	35
	1/21	R88G-HPG50A21900TB□	1	149	156	170	□130	190	145	165	163	122	103	12	53
	1/33	R88G-HPG50A33900TB□	1	149	156	170	□130	190	145	165	163	122	103	12	53
2 kW	1/5	R88G-HPG32A052K0TB□	1	129	133	120	□180	135	200	115	114	84	98	12.5	35
	1/11	R88G-HPG50A112K0TB□	1	149	156	170	□180	190	200	165	163	122	103	12	53
	1/21	R88G-HPG50A212K0TB□	1	231	222	230	□180	260	200	220	214	168	165	12	53
	1/25	R88G-HPG65A255K0SBD□	1	231	222	230	□180	260	200	220	214	168	165	12	57

Corrected Contents

● For 1,000-r/min Servomotors (900 W to 3 kW)

Model	Outline drawing	Dimensions [mm]													
		LM	LR	C1	C2	D1	D2	D3	D4	D5	E	F1	F2		
900 W	1/5	R88G-HPG32A05900TB□	1	129	133	120	□130	135	145	115	114	84	98	12.5	35
	1/11	R88G-HPG32A11900TB□	1	129	133	120	□130	135	145	115	114	84	98	12.5	35
	1/21	R88G-HPG50A21900TB□	1	149	156	170	□130	190	145	165	163	122	103	12	53
	1/33	R88G-HPG50A33900TB□	1	149	156	170	□130	190	145	165	163	122	103	12	53
2 kW	1/5	R88G-HPG32A052K0TB□	1	129	133	120	□180	135	200	115	114	84	98	12.5	35
	1/11	R88G-HPG50A112K0TB□	1	149	156	170	□180	190	200	165	163	122	103	12	53
	1/21	R88G-HPG50A212K0TB□	1	149	156	170	□180	190	200	165	163	122	103	12	53
	1/25	R88G-HPG65A255K0SBD□	1	231	222	230	□180	260	200	220	214	168	165	12	57

Current Contents

Dimensions [mm]												Model		
G	S	T	Z1	Z2	AT ⁻¹	Key				Tap				
						QK	b	h	t1	M	L			
13	40	82	11	M8 x 25	M6	70	12	8	5	M10	20	R88G-HPG32A05900TB□	1/5	900 W
13	40	82	11	M8 x 25	M6	70	12	8	5	M10	20	R88G-HPG32A11900TB□	1/11	
16	50	82	14	M8 x 25	M6	70	14	9	5.5	M10	20	R88G-HPG50A21900TB□	1/21	
16	50	82	14	M8 x 25	M6	70	14	9	5.5	M10	20	R88G-HPG50A33900TB□	1/33	2 kW
13	40	82	11	M12 x 25	M6	70	12	8	5	M10	20	R88G-HPG32A052K0TB□	1/5	
16	50	82	14	M12 x 25	M6	70	14	9	5.5	M10	20	R88G-HPG50A112K0TB□	1/11	
25	80	130	18	M12 x 25	M8	110	22	14	9	M16	35	R88G-HPG50A212K0TB□	1/21	
25	80	130	18	M12 x 25	M8	110	22	14	9	M16	35	R88G-HPG65A255K0SB□	1/25	

Corrected Contents

Dimensions [mm]												Model		
G	S	T	Z1	Z2	AT ⁻¹	Key				Tap				
						QK	b	h	t1	M	L			
13	40	82	11	M8 x 25	M6	70	12	8	5	M10	20	R88G-HPG32A05900TB□	1/5	900 W
13	40	82	11	M8 x 25	M6	70	12	8	5	M10	20	R88G-HPG32A11900TB□	1/11	
16	50	82	14	M8 x 25	M6	70	14	9	5.5	M10	20	R88G-HPG50A21900TB□	1/21	
16	50	82	14	M8 x 25	M6	70	14	9	5.5	M10	20	R88G-HPG50A33900TB□	1/33	2 kW
13	40	82	11	M12 x 25	M6	70	12	8	5	M10	20	R88G-HPG32A052K0TB□	1/5	
16	50	82	14	M12 x 25	M6	70	14	9	5.5	M10	20	R88G-HPG50A112K0TB□	1/11	
16	50	82	14	M12 x 25	M6	70	14	9	5.5	M10	20	R88G-HPG50A212K0TB□	1/21	
25	80	130	18	M12 x 25	M8	110	22	14	9	M16	35	R88G-HPG65A255K0SB□	1/25	

© **OMRON, 2012**

All rights reserved. No part of this publication may be reproduced, stored in a retrieval system, or transmitted, in any form, or by any means, mechanical, electronic, photocopying, recording, or otherwise, without the prior written permission of OMRON.

No patent liability is assumed with respect to the use of the information contained herein. Moreover, because OMRON is constantly striving to improve its high-quality products, the information contained in this manual is subject to change without notice. Every precaution has been taken in the preparation of this manual. Nevertheless, OMRON assumes no responsibility for errors or omissions. Neither is any liability assumed for damages resulting from the use of the information contained in this publication.

Introduction

Thank you for purchasing an OMNUC G5-series Servo Drive (Pulse-train Input Type). This User's Manual describes the installation and wiring methods of the OMNUC G5-series Servo Drives (Pulse-train Input Type) and parameter setting method which is required for the operation, as well as troubleshooting and inspection methods.

Intended Audience

This User's Manual is intended for the following personnel, who must also have knowledge of electrical systems (an electrical engineer or the equivalent).

- Personnel in charge of introducing the FA equipment
- Personnel in charge of designing the FA systems
- Personnel in charge of managing the FA systems and facilities

Notice

This User's Manual contains information you need to know to correctly use the OMNUC G5-series Servo Drives (Pulse-train Input Type) and peripheral equipment.

Before using the Servo Drive, read this User's Manual and gain a full understanding of the information provided herein.

After you finished reading this User's Manual, keep it in a convenient place so that it can be referenced at any time.

Make sure this User's Manual is delivered to the end user.

Read and Understand this Manual

Warranty and Limitations of Liability

<i>WARRANTY</i>
<p>OMRON's exclusive warranty is that the products are free from defects in materials and workmanship for a period of one year (or other period if specified) from date of sale by OMRON.</p> <p>OMRON MAKES NO WARRANTY OR REPRESENTATION, EXPRESS OR IMPLIED, REGARDING NONINFRINGEMENT, MERCHANTABILITY, OR FITNESS FOR PARTICULAR PURPOSE OF THE PRODUCTS.</p> <p>ANY BUYER OR USER ACKNOWLEDGES THAT THE BUYER OR USER ALONE HAS DETERMINED THAT THE PRODUCTS WILL SUITABLY MEET THE REQUIREMENTS OF THEIR INTENDED USE. OMRON DISCLAIMS ALL OTHER WARRANTIES, EXPRESS OR IMPLIED.</p>

<i>LIMITATIONS OF LIABILITY</i>
<p>OMRON SHALL NOT BE RESPONSIBLE FOR SPECIAL, INDIRECT, OR CONSEQUENTIAL DAMAGES, LOSS OF PROFITS OR COMMERCIAL LOSS IN ANY WAY CONNECTED WITH THE PRODUCTS, WHETHER SUCH CLAIM IS BASED ON CONTRACT, WARRANTY, NEGLIGENCE, OR STRICT LIABILITY.</p> <p>In no event shall the responsibility of OMRON for any act exceed the individual price of the product on which liability is asserted.</p> <p>IN NO EVENT SHALL OMRON BE RESPONSIBLE FOR WARRANTY, REPAIR, OR OTHER CLAIMS REGARDING THE PRODUCTS UNLESS OMRON'S ANALYSIS CONFIRMS THAT THE PRODUCTS WERE PROPERLY HANDLED, STORED, INSTALLED, AND MAINTAINED AND NOT SUBJECT TO CONTAMINATION, ABUSE, MISUSE, OR INAPPROPRIATE MODIFICATION OR REPAIR.</p>

Application Considerations

SUITABILITY FOR USE

OMRON shall not be responsible for conformity with any standards, codes, or regulations that apply to the combination of products in the customer's application or use of the products.

At the customer's request, OMRON will provide applicable third party certification documents identifying ratings and limitations of use that apply to the products. This information by itself is not sufficient for a complete determination of the suitability of the products in combination with the end product, machine, system, or other application or use.

The following are some examples of applications for which particular attention must be given. This is not intended to be an exhaustive list of all possible uses of the products, nor is it intended to imply that the uses listed may be suitable for the products:

- Outdoor use, uses involving potential chemical contamination or electrical interference, or conditions or uses not described in this manual.
- Nuclear energy control systems, combustion systems, railroad systems, aviation systems, medical equipment, amusement machines, vehicles, safety equipment, and installations subject to separate industry or government regulations.
- Systems, machines, and equipment that could present a risk to life or property. Please know and observe all prohibitions of use applicable to the products.

NEVER USE THE PRODUCTS FOR AN APPLICATION INVOLVING SERIOUS RISK TO LIFE OR PROPERTY WITHOUT ENSURING THAT THE SYSTEM AS A WHOLE HAS BEEN DESIGNED TO ADDRESS THE RISKS, AND THAT THE OMRON PRODUCTS ARE PROPERLY RATED AND INSTALLED FOR THE INTENDED USE WITHIN THE OVERALL EQUIPMENT OR SYSTEM.

PROGRAMMABLE PRODUCTS

OMRON shall not be responsible for the user's programming of a programmable product, or any consequence thereof.

Disclaimers

CHANGE IN SPECIFICATIONS

Product specifications and accessories may be changed at any time based on improvements and other reasons. It is our practice to change model numbers when published ratings or features are changed, or when significant construction changes are made. However, some specifications of the products may be changed without any notice. When in doubt, special model numbers may be assigned to fix or establish key specifications for your application on your request. Please consult with your OMRON representative at any time to confirm actual specifications of purchased products.

DIMENSIONS AND WEIGHTS

Dimensions and weights are nominal and are not to be used for manufacturing purposes, even when tolerances are shown.

PERFORMANCE DATA

Performance data given in this manual is provided as a guide for the user in determining suitability and does not constitute a warranty. It may represent the result of OMRON's test conditions, and the users must correlate it to actual application requirements. Actual performance is subject to the OMRON Warranty and Limitations of Liability.

ERRORS AND OMISSIONS

The information in this manual has been carefully checked and is believed to be accurate; however, no responsibility is assumed for clerical, typographical, or proofreading errors, or omissions.

Safety Precautions

To ensure that the OMNUC G5-series (Pulse-train Input Type) Servomotor/Servo Drive as well as peripheral equipment are used safely and correctly, be sure to read this Safety Precautions section and the main text before using the product. Learn all items you should know before use, regarding the equipment as well as the required safety information and precautions.

Make an arrangement so that this User's Manual also gets to the end user of this product.

After reading this User's Manual, keep it in a convenient place so that it can be referenced at any time.

Explanation of Displays

The precautions explained in this section describe important information regarding safety and must be followed without fail.

The displays of precautions in this User's Manual and their meanings are explained below.



DANGER

Indicates a potentially hazardous situation which, if not avoided, could result in death or serious injury. Additionally, there may be severe property damage.



Caution

Indicates a potentially hazardous situation which, if not avoided, may result in minor or moderate injury, or property damage.

Even those items denoted by the caution symbol may lead to a serious outcome depending on the situation. Accordingly, be sure to observe all safety precautions.



Precautions for Safe Use

Precautions on what to do and what not to do to ensure safe usage of the product.



Precautions for Correct Use

Precautions on what to do and what not to do to ensure proper operation and performance.



Additional Information

This information is provided to increase understanding or make operation easier.

Explanation of Symbols



△ This symbol indicates danger and caution.

The specific instruction is indicated using an illustration or text inside or near △. The symbol shown to the left indicates "beware of electric shock."



⊘ This symbol indicates a prohibited item (an item you must not do).

The specific instruction is indicated using an illustration or text inside or near ⊘. The symbol shown to the left indicates "disassembly prohibited."

















● This symbol indicates a compulsory item (an item that must be done).

The specific instruction is indicated using an illustration or text inside or near ●. The symbol shown to the left indicates "grounding required."









Precautions for Safe Use of This Product

Illustrations contained in this User's Manual sometimes depict conditions without covers and safety shields for the purpose of showing the details. When using this product, be sure to install the covers and shields as specified and use the product according to this User's Manual.

If the product has been stored for an extended period of time, contact your OMRON sales representative.

 DANGER	
	<p>Be sure to ground the frame ground terminals for the Servo Drive and Servomotor with 100 VAC or 200 VAC to 100 Ω or less, and for the Servo Drive and Servomotor with 400 VAC to 10 Ω or less.</p> <p>Electric shock may result.</p>
	<p>Never put your hand inside the Servo Drive.</p> <p>Electric shock may result.</p>
	<p>While the power is supplied, do not remove the front cover, terminal covers, cables, and options.</p> <p>Electric shock may result.</p>
	<p>Operation, maintenance or inspection by unauthorized personnel is prohibited.</p> <p>Electric shock or injury may result.</p>
	<p>Before carrying out wiring or inspection, turn OFF the main circuit power and wait for at least 15 minutes.</p> <p>Electric shock may result.</p>
	<p>Do not damage, pull, stress strongly, pinch the cables or place heavy articles on them.</p> <p>Electric shock, malfunction, or burn damage may result.</p>
	<p>Never enter the operating area during operation.</p> <p>Injury may result.</p>
	<p>Never modify the Servo Drive.</p> <p>Injury or equipment damage may result.</p>
	<p>Install a stopping device on the machine to ensure safety.</p> <p>* The holding brake is not a stopping device to ensure safety.</p> <p>Injury may result.</p>
	<p>Install an immediate stop device externally to the machine so that the operation can be stopped and the power supply cut off immediately.</p> <p>Injury may result.</p>
	<p>When the power is restored after a momentary power interruption, the machine may restart suddenly. Never come close to the machine when restoring power.</p> <p>* Implement measures to ensure safety of people nearby even when the machine is restarted.</p> <p>Injury may result.</p>
	<p>After an earthquake, be sure to conduct safety checks.</p> <p>Electric shock, injury, or fire may result.</p>
	<p>Never drive the Servomotor using an external drive source.</p> <p>Fire may result.</p>

⚠ DANGER



	Do not place flammable materials near the Servomotor, Servo Drive, or Regeneration Resistor. Fire may result.
	Install the Servomotor, Servo Drive, and Regeneration Resistor on non-flammable materials such as metals. Fire may result.
	Do not use the Servomotor with cables submerged in oil or water. Electric shock, injury, or fire may result.
	Never connect a power supply directly to the Servomotor. Fire or failure may result.
	Do not perform wiring or any operation with wet hands. Electric shock, injury, or fire may result.
	Do not touch the key grooves with bare hands if a Servomotor with shaft-end key grooves is being used. Injury may result.
	Install the Servomotor and Servo Drive before wiring them. Electric shock may result.
	The Servo Drive radiator, Regeneration Resistor, Servomotor, etc., may become hot while the power is supplied or remain hot for a while even after the power supply is cut off. Never touch these components. Burn injury may result.
	Use the Servomotor and Servo Drive in a specified combination. Fire or equipment damage may result.

⚠ Caution

	<p>Do not store or install the Servo Drive in the following locations:</p> <ul style="list-style-type: none"> • Location subject to direct sunlight • Location where the ambient temperature exceeds the specified level • Location where the relative humidity exceeds the specified level • Location subject to condensation due to rapid temperature changes • Location subject to corrosive or flammable gases • Location subject to high levels of dust, salt content, or iron dust • Location subject to splashes of water, oil, chemicals, etc. • Location where the Servo Drive may receive vibration or impact directly <p>Electric shock, fire, or equipment damage may result.</p>
---	---

Storage and Transportation















Caution

	When transporting the Servo Drive, do not hold it by the cables or Servomotor shaft. Injury or failure may result.
	Do not overload the Servo Drive or Servomotor. (Follow the instructions on the product label.) Injury or failure may result.
	Use the Servomotor eye-bolts only when transporting the Servomotor. Do not use them to transport the machine. Injury or failure may result.













Installation and Wiring





Caution

	Do not step on the Servo Drive or place heavy articles on it. Injury may result.
	Do not block the intake or exhaust openings. Do not allow foreign objects to enter the Servo Drive. Fire may result.
	Be sure to observe the mounting direction. Failure may result.
	Provide the specified clearance between the Servo Drive and the inner surface of the control panel or other equipment. Fire or failure may result.
	Do not apply strong impact on the Servo Drive. Failure may result.
	Wire the cables correctly and securely. Runaway Servomotor, injury, or failure may result.
	Tighten the Servo Drive mounting screws, terminal block screws, and cable screws to the specified torque. Failure may result.
	Use crimp terminals to wire screw type terminal blocks. Do not connect bare stranded wires directly to terminals blocks. Fire may result.
	Only use the power supply voltage specified in this User's Manual. Burn damage may result.
	In locations where the power supply infrastructure is poor, make sure the rated voltage can be supplied. Failure may result.
	Provide safety measures, such as a breaker, to protect against short circuiting of external wiring. Fire may result.
	If the Servo Drive is used in the following locations, provide sufficient shielding measures. <ul style="list-style-type: none"> • Location subject to static electricity or other forms of noise • Location subject to a strong electric or magnetic field • Location where exposure to radioactivity may occur • Location near power supply lines Failure may result.
	Connect an immediate stop relay in series with the brake control relay. Injury or failure may result.
	When connecting the battery, make sure the polarity is correct. Battery damage or explosion may result.

Operation and Adjustment

 Caution	
	Conduct a test operation after confirming that the equipment is not affected. Equipment damage may result.
	Before operating the Servo Drive in an actual environment, check if it operates correctly based on the parameters you have set. Equipment damage may result.
	Never adjust or set parameters to extreme values, because it will make the operation unstable. Injury may result.
	Separate the Servomotor from the mechanical system and check its operation before installing the Servomotor to the machine. Injury may result.
	If an error (alarm) occurs, remove the cause and ensure safety, and then reset the error (alarm) and restart the operation. Injury may result.
	Do not use the built-in brake of the Servomotor for normal braking operation. Failure may result.
	Do not operate the Servomotor connected to an excessive load inertia. Failure may result.
	Install protective and safety devices to prevent idling or locking of the electromagnetic brake or the gear head, or leakage of grease from the gear head. Injury, damage, or taint damage result.
	If the Servo Drive fails, cut off the power supply to the Servo Drive at the power supply. Fire may result.
	Do not turn ON and OFF the main Servo Drive power supply frequently. Failure may result.
	Do not apply strong impact on the Servomotor shaft or Servo Drive. Failure may result.
	The Servomotor may not be able to keep a stopped state without control. Install an appropriate stopping device to ensure safety. Equipment damage or injury may result.

Maintenance and Inspection **Caution**

	After replacing the Servo Drive, transfer to the new Servo Drive all data needed to resume operation, before restarting operation. Equipment damage may result.
	Never repair the Servo Drive by disassembling it. Electric shock or injury may result.
	Be sure to turn OFF the power supply when the Servo Drive is not going to be used for a prolonged period of time. Injury or malfunction may result.

Location of Warning Label

The Servo Drive bears a warning label at the following location to provide handling warnings. When handling the Servo Drive, be sure to observe the instructions provided on this label.

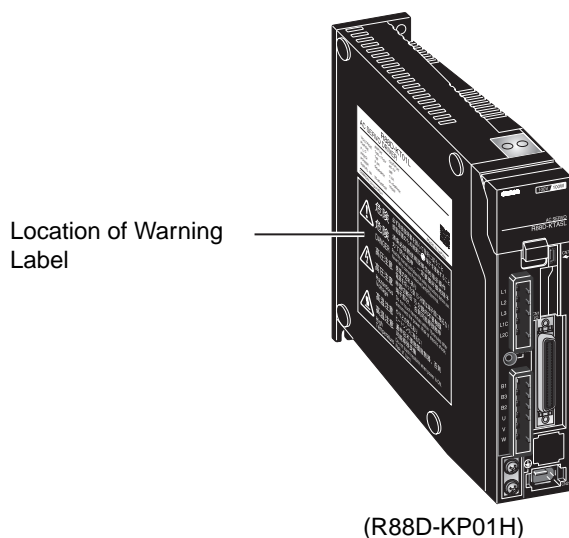

Instructions on Warning Label

	危険 危険 DANGER	必ず取扱説明書を読んで指示に従うこと 感電保護のため確実にⓍ端子を接地すること 请务必按照使用说明书的指示操作 为了防止触电，一定要接好接地端子 Read the manual and follow the safety instructions before use. Never fail to connect Protective Earth(PE) terminal.
	高压注意 高压注意 Hazardous Voltage	感電の恐れあり 電源を切った後15分間は端子部に触るな! 电源切断后15分钟内不要触摸 端子部分，否则可能导致触电 Do not touch terminals within 15 minutes after disconnect the power. Risk of electric shock.
	高温注意 高温注意 High Temperature	やけどの恐れあり ヒートシンクに触るな! 通电后不要触摸散热器，否则 可能导致受伤 Do not touch heatsink when power is ON. Risk of burn.

Disposal

- When disposing of the battery, insulate it using tape, and dispose of it by following the applicable ordinances of your local government.
- Dispose of the Servo Drive as industrial waste.

Items to Check After Unpacking

After unpacking, check the following items.

- Is this the model you ordered?
- Was there any damage sustained during shipment?

Accessories

Safety Precautions document × 1 copy

- Connectors, mounting screws, mounting brackets, and other accessories other than those in the table below are not supplied. They must be prepared by the customer.
- If any item is missing or a problem is found such as Servo Drive damage, contact the OMRON dealer or sales office where you purchased your product.

Specifications		Connector for main circuit power supply terminals and control circuit power supply terminals	Connector for External Regeneration Resistor connection terminals and Motor connection terminals	Safety connector	Mounting brackets
Single-phase/ 3-phase 200 VAC	100 W	Included		Included	-
	200 W				
	400 W				
	750 W				
	1 kW				
	1.5 kW				
3-phase 200 VAC	2 kW	-			Included
	3 kW				
	5 kW				

Revision History

The manual revision code is a number appended to the end of the catalog number found in the bottom right-hand corner of the front and back covers.

Example

Cat.No.	I584-E1-02
----------------	-------------------

↑
Revision code

Revision Code	Revision Date	Revised Content
01	April 2012	Original production
02	August 2012	<p>Front cover: Corrected model numbers.</p> <p>Pages 2-16 and 2-17: Corrected specifications and deleted rows in middle table.</p> <p>Page 3-63: Deleted rows from middle two tables.</p> <p>Pages 3-69, 3-73, 3-76, and 3-79: Corrected specifications in parentheses before table.</p> <p>Pages 3-70, 3-74, 3-77, and 3-80: Deleted page.</p> <p>Page 4-6: Corrected bolt sizes and removed columns from middle table.</p>

Manual Configuration

This User's Manual consists of the following sections.

Read the necessary section or sections referring the following table.

		Outline
Section 1	Features and System Configuration	This section explains the features of the Servo Drive, name of each part, and applicable EC Directives and UL standards.
Section 2	Models and External Dimensions	This section explains the models of Servo Drives, Servomotors, Decelerators, and peripheral devices, and provides the external dimensions and mounting dimensions.
Section 3	Specifications	This section provides the general specifications, characteristics, connector specifications, and I/O circuits of the Servo Drives as well as the general specifications, characteristics, encoder specifications of the Servomotors and other peripheral devices.
Section 4	System Design	This section explains the installation conditions, wiring methods which include wiring conforming to EMC directives, and regenerative energy calculation methods for the Servo Drives, Servomotors, and Decelerators. It also explains the performance of External Regeneration Resistors.
Section 5	Basic Control Mode	This section provides the outline of functions and settings for each control mode.
Section 6	Applied Functions	This section provides the outline and settings of the applied functions such as damping control, electronic gear, gain switching, and disturbance observer.
Section 7	Parameter Details	This section explains the set value and setting details of each parameter.
Section 8	Operation	This section gives the operational procedure and explains how to operate in each mode.
Section 9	Adjustment Functions	This section explains the functions, setting methods, and items to note regarding various gain adjustments.
Section 10	Troubleshooting and Maintenance	This section explains the items that must be checked when problems occur, error diagnosis using the alarm display and measures, error diagnosis based on the operating condition and measures, and periodic maintenance.
Appendices		The appendices provide connection examples with OMRON's PLC and Position Controller, as well as lists of parameters.

Manual Structure

Page Structure and Symbol Icons

The following page structure and symbol icons are used in this User's Manual.

- Level 1 heading →
- Level 2 heading →
- Level 3 heading →

Note, Supplementary Information, Reference Target

A note, supplementary information, reference target, etc. are provided with difference icons.



6 Applied Functions

6-11 Disturbance Observer Function

6-11-1 Outline of the Function

The disturbance observer function enables you to lower the effect of the disturbance torque and reduce vibration by using the estimated disturbance torque value.

You can use the disturbance observer for position control or speed control in the following situations.

- The servo is ON.
- The Servomotor can rotate normally without any failures.
- The realtime autotuning function is disabled.
- The instantaneous speed observer function is disabled.

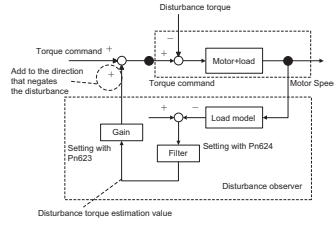

Precautions for Correct Use

If there is a resonance point below the cut-off frequency estimated by the disturbance observer, or if the disturbance torque contains a large amount of high-frequency content, the disturbance observer may not produce the expected results.

6 - 41 OMNUC G5-series (Pulse-train Input Type) AC Servomotors and Servo Drives User's Manual

Manual Name

Operation Steps

Describes the operation steps.

6 Applied Functions

6-11-2 Parameters Requiring Settings

Parameter No.	Name	Description	Reference
Pr#10	Function Expansion Setting	Set the bits related to the disturbance observer.	P7-56
Pr#23	Disturbance Torque Compensation Gain	Set the compensation gain for the disturbance torque.	P7-58
Pr#24	Disturbance Observer Filter Setting	Set the filter time constant for disturbance torque compensation.	P7-58

6-11-3 Operating Procedure

- 1 Set Function Expansion Setting (Pr#10).**
Set whether to enable or disable the disturbance observer in bit 1.
0: Disabled
1: Enabled
Set the operating conditions for enabling the function in bit 2.
0: Enabled at all time
1: Enabled only when Gain 1 is selected
- 2 Set Disturbance Observer Filter Setting (Pr#24).**
Set a small value in Disturbance Torque Compensation Gain (Pr#23). Change the value in Disturbance Observer Filter Setting (Pr#24) from a large value to a smaller one to determine a setting that provides a balance between the effect of suppressing the influence of disturbance and the operating noise level.
- 3 Set Disturbance Torque Compensation Gain (Pr#23).**
Change the value of Disturbance Torque Compensation Gain (Pr#23) from a small value to a larger value to determine a setting that provides a balance between the effect of suppressing the influence of disturbance and the operating noise level.

6 - 42 OMNUC G5-series (Pulse-train Input Type) AC Servomotors and Servo Drives User's Manual

6-11 Disturbance Observer Function

6

6-11-1 Outline of the Function

- Level 2 heading Shows which sub-section the content of the current page belongs to.
- Section Number of Level 1 heading Shows which section the content of the current page belongs to.
- Level 3 heading Shows which paragraph the content of the current page belongs to.

Note The above page is only a sample for illustrative purposes. It is not the actual content of this User's Manual.

Special Information

Special information in this manual is classified as follows:



Precautions for Safe Use

Precautions on what to do and what not to do to ensure safe usage of the product.



Precautions for Correct Use

Precautions on what to do and what not to do to ensure proper operation and performance.



Additional Information

Additional information to read as required.

This information is provided to increase understanding or make operation easier.

Sections in this Manual

1	Features and System Configuration	10	Troubleshooting and Maintenance	1	10
2	Models and External Dimensions	A	Appendices	2	A
3	Specifications			3	
4	System Design			4	
5	Basic Control Mode			5	
6	Applied Functions			6	
7	Parameter Details			7	
8	Operation			8	
9	Adjustment Functions			9	

CONTENTS

Introduction	1
Read and Understand this Manual	2
Safety Precautions	5
Items to Check After Unpacking	13
Revision History	14
Manual Configuration	15
Manual Structure	16
Sections in this Manual	19
CONTENTS	20

Section 1 Features and System Configuration

1-1 Outline	1-2
1-1-1 Outline of OMNUC G5-series Servo Drives (Pulse-train Input Type).....	1-2
1-1-2 Features of OMNUC G5-series Servo Drives (Pulse-train Input Type).....	1-2
1-2 System Configuration	1-3
1-3 Names and Functions	1-4
1-3-1 Servo Drive Part Names	1-4
1-3-2 Servo Drive Functions.....	1-5
1-4 System Block Diagram.....	1-6
1-5 Applicable Standards	1-10
1-5-1 EC Directives	1-10
1-5-2 UL and cUL Standards.....	1-10
1-5-3 SEMI F47	1-10

Section 2 Models and External Dimensions

2-1 Servo System Configuration	2-2
2-2 How to Read Model Numbers	2-4
2-2-1 Servo Drive	2-4
2-2-2 Servomotor	2-5
2-2-3 Decelerator (Backlash: 3 Arcminutes max.).....	2-6
2-2-4 Decelerator (Backlash: 15 Arcminutes max.).....	2-7
2-3 Model Tables	2-8
2-3-1 Servo Drive Model Table	2-8
2-3-2 Servomotor Model Tables	2-8
2-3-3 Servo Drive and Servomotor Combination Tables	2-11
2-3-4 Decelerator Model Tables	2-12
2-3-5 Cable and Peripheral Device Model Tables.....	2-16

2-4	External and Mounting Dimensions	2-22
2-4-1	Servo Drive Dimensions	2-22
2-4-2	Servomotor Dimensions	2-31
2-4-3	Combinations of Servomotors and Decelerators	2-40
2-4-4	Decelerator Dimensions	2-42
2-4-5	External Regeneration Resistor Dimensions	2-56
2-4-6	Reactor Dimensions	2-57
2-4-7	Mounting Bracket (L-brackets for Rack Mounting) Dimensions	2-61

Section 3 Specifications

3-1	Servo Drive Specifications	3-2
3-1-1	General Specifications	3-2
3-1-2	Characteristics	3-3
3-1-3	Main Circuit and Motor Connections	3-6
3-1-4	Control I/O Connector Specifications (CN1)	3-9
3-1-5	Control Input Circuits	3-15
3-1-6	Control Input Details	3-17
3-1-7	Control Output Circuits	3-27
3-1-8	Control Output Details	3-28
3-1-9	Encoder Connector Specifications (CN2)	3-32
3-1-10	Analog Monitor Connector Specifications (CN5)	3-33
3-1-11	USB Connector Specifications (CN7)	3-34
3-2	Overload Characteristics (Electronic Thermal Function)3-35	
3-2-1	Overload Characteristics Graphs	3-35
3-3	Servomotor Specifications	3-36
3-3-1	General Specifications	3-36
3-3-2	Characteristics	3-37
3-3-3	Encoder Specifications	3-53
3-4	Decelerator Specifications	3-54
3-4-1	Models and Specifications	3-54
3-5	Cable and Connector Specifications	3-62
3-5-1	Resistance to Bending of Global Flexible Cable	3-62
3-5-2	Encoder Cable Specifications	3-64
3-5-3	Motor Power Cable Specifications	3-68
3-5-4	Connector Specifications	3-80
3-5-5	Analog Monitor Cable Specifications	3-83
3-5-6	Control Cable Specifications	3-84
3-6	Servo Relay Unit and Cable Specifications	3-96
3-6-1	Servo Relay Unit Specifications	3-96
3-6-2	Servo Drive Relay Unit Cable Specifications	3-108
3-6-3	Position Control Unit Relay Unit Cable Specifications	3-111
3-7	External Regeneration Resistor Specifications	3-122
3-7-1	External Regeneration Resistor Specifications	3-122
3-8	Reactor Specifications	3-124

Section 4 System Design

4-1	Installation Conditions	4-2
4-1-1	Servo Drive Installation Conditions	4-2
4-1-2	Servomotor Installation Conditions	4-3
4-1-3	Decelerator Installation Conditions	4-6
4-2	Wiring	4-10
4-2-1	Peripheral Equipment Connection Examples	4-10
4-2-2	Main Circuit and Motor Connections	4-14

4-3	Wiring Conforming to EMC Directives.....	4-20
4-3-1	Wiring Method.....	4-20
4-3-2	Selecting Connection Components.....	4-26
4-4	Regenerative Energy Absorption.....	4-39
4-4-1	Calculating the Regenerative Energy.....	4-39
4-4-2	Servo Drive Regeneration Absorption Capacity.....	4-41
4-4-3	Regenerative Energy Absorption with an External Regeneration Resistor.....	4-42
4-4-4	Connecting an External Regeneration Resistor.....	4-43

Section 5 Basic Control Mode

5-1	Position Control.....	5-2
5-1-1	Outline of the Function.....	5-2
5-1-2	Parameters Requiring Settings.....	5-3
5-1-3	Related Functions.....	5-5
5-1-4	Parameter Block Diagram for Position Control Mode.....	5-6
5-2	Internally Set Speed Control.....	5-7
5-2-1	Outline of the Function.....	5-7
5-2-2	Parameters Requiring Settings.....	5-7
5-2-3	Related Functions.....	5-11
5-2-4	Parameter Block Diagram for Speed Control Mode.....	5-12
5-3	Switching Control.....	5-13
5-3-1	Outline of the Function.....	5-13
5-3-2	Parameters Requiring Settings.....	5-13
5-3-3	Related Functions.....	5-14

Section 6 Applied Functions

6-1	Damping Control.....	6-3
6-1-1	Outline of the Function.....	6-3
6-1-2	Parameters Requiring Settings.....	6-3
6-2	Adaptive Filter.....	6-6
6-2-1	Outline of the Function.....	6-6
6-2-2	Parameters Requiring Settings.....	6-7
6-3	Notch Filters.....	6-8
6-3-1	Outline of the Function.....	6-8
6-3-2	Parameters Requiring Settings.....	6-9
6-4	Electronic Gear Function.....	6-11
6-4-1	Outline of the Function.....	6-11
6-4-2	Parameters Requiring Settings.....	6-11
6-4-3	Operation Example.....	6-13
6-5	Encoder Dividing Function.....	6-15
6-5-1	Outline of the Function.....	6-15
6-5-2	Parameters Requiring Settings.....	6-15
6-6	Brake Interlock.....	6-18
6-6-1	Outline of the Function.....	6-18
6-6-2	Parameters Requiring Settings.....	6-18
6-6-3	Precautions for Correct Use of Holding Brake.....	6-18
6-6-4	Operation.....	6-19
6-7	Gain Switching Function.....	6-23
6-7-1	Outline of the Function.....	6-23
6-7-2	Parameters Requiring Settings.....	6-24
6-8	Torque Limit.....	6-31
6-8-1	Outline of the Function.....	6-31

6-9	Sequence I/O Signals	6-33
6-9-1	Outline of the Function.....	6-33
6-9-2	Input Signals.....	6-33
6-9-3	Output Signals	6-36
6-10	Forward and Reverse Drive Prohibition Functions	6-38
6-10-1	Outline of the Function.....	6-38
6-10-2	Parameters Requiring Settings.....	6-38
6-11	Disturbance Observer Function	6-41
6-11-1	Outline of the Function.....	6-41
6-11-2	Parameters Requiring Settings.....	6-42
6-11-3	Operating Procedure	6-42
6-12	Gain 3 Switching Function	6-43
6-12-1	Outline of the Function.....	6-43
6-12-2	Parameters Requiring Settings.....	6-43
6-12-3	Operation.....	6-43
6-13	Friction Torque Compensation Function	6-44
6-13-1	Outline of the Function.....	6-44
6-13-2	Parameters Requiring Settings.....	6-44
6-13-3	Operation Example.....	6-45
6-14	Inertia Ratio Switching Function	6-46
6-14-1	Outline of the Function.....	6-46
6-14-2	Parameters Requiring Settings.....	6-46
6-14-3	Operating Procedure	6-46
6-15	Feed-forward Function	6-47
6-15-1	Outline of the Function.....	6-47
6-15-2	Parameters Requiring Settings.....	6-47
6-15-3	Operating Procedure	6-48
6-16	Instantaneous Speed Observer Function	6-50
6-16-1	Outline of the Function.....	6-50
6-16-2	Parameters Requiring Settings.....	6-50
6-16-3	Operating Procedure	6-51

Section 7 Parameter Details

7-1	Basic Parameters	7-2
7-2	Gain Parameters	7-10
7-3	Vibration Suppression Parameters	7-20
7-4	Analog Control Parameters	7-26
7-5	Interface Monitor Setting Parameters	7-32
7-6	Extended Parameters	7-42
7-7	Special Parameters	7-55

Section 8 Operation

8-1	Operational Procedure	8-2
8-2	Preparing for Operation	8-3
8-2-1	Items to Check Before Turning ON the Power Supply	8-3
8-2-2	Turning ON the Power Supply.....	8-4
8-2-3	Checking the Display	8-4
8-3	Using the Front Panel Display	8-5

8-4	Mode Setting	8-6
8-4-1	Changing the Mode.....	8-6
8-4-2	Monitor Mode.....	8-7
8-4-3	Parameter Setting Mode	8-19
8-4-4	Parameter Write Mode	8-21
8-4-5	Auxiliary Function Mode.....	8-22
8-5	Trial Operation	8-28
8-5-1	Preparations for Trial Operation	8-28
8-5-2	Trial Operation in Position Control Mode.....	8-29

Section 9 Adjustment Functions

9-1	Gain Adjustment	9-2
9-1-1	Purpose of the Gain Adjustment	9-2
9-1-2	Gain Adjustment Methods.....	9-2
9-1-3	Gain Adjustment Procedure	9-3
9-2	Realtime Autotuning	9-4
9-2-1	Setting Realtime Autotuning.....	9-5
9-2-2	Setting Machine Rigidity.....	9-5
9-3	Manual Tuning	9-11
9-3-1	Basic Settings	9-11

Section 10 Troubleshooting and Maintenance

10-1	Actions for Problems	10-2
10-1-1	Preliminary Checks When a Problem Occurs	10-2
10-1-2	Precautions When a Problem Occurs	10-3
10-1-3	Replacing the Servomotor or Servo Drive.....	10-4
10-2	Warning List	10-5
10-3	Alarm List	10-6
10-4	Troubleshooting	10-10
10-4-1	Error Diagnosis with Alarm Displays	10-10
10-4-2	Error Diagnosis Using the Operation State	10-17
10-5	Periodic Maintenance	10-21
10-5-1	Servomotor Life Expectancy	10-21
10-5-2	Servo Drive Life Expectancy	10-22

Appendices

A-1	Connection Examples	A-2
A-2	Parameter List	A-11

1

Features and System Configuration

This section explains the features of the Servo Drive, name of each part, and applicable EC Directives and UL standards.

1-1	Outline	1-2
1-1-1	Outline of OMNUC G5-series Servo Drives (Pulse-train Input Type)	1-2
1-1-2	Features of OMNUC G5-series Servo Drives (Pulse-train Input Type)	1-2
1-2	System Configuration	1-3
1-3	Names and Functions	1-4
1-3-1	Servo Drive Part Names	1-4
1-3-2	Servo Drive Functions	1-5
1-4	System Block Diagram	1-6
1-5	Applicable Standards	1-10
1-5-1	EC Directives	1-10
1-5-2	UL and cUL Standards	1-10
1-5-3	SEMI F47	1-10

1-1 Outline

1-1-1 Outline of OMNUC G5-series Servo Drives (Pulse-train Input Type)

The OMNUC G5-series Servo Drives (Pulse-train Input Type) are AC Servo Drives with the position control and speed control capabilities.

The OMNUC G5-series provides a wide portfolio of products, which supports the motor capacity from 50 W to 5 kW and 200 V input power supply, to suit various applications of customers.

The Servomotors with high-resolution 20-bit incremental encoder are available.

As for gain adjustment, the OMNUC G5-series Servo Drives support the realtime autotuning and adaptive filter functions that automatically perform complicated gain adjustment. A notch filter can also be automatically set to suppress machine vibration by reducing machine resonance during operation. The damping control function of the Servomotor and Servo Drive realizes stable stopping performance in a mechanism which vibrates because of the low rigidity of the load.

1-1-2 Features of OMNUC G5-series Servo Drives (Pulse-train Input Type)

The OMNUC G5-series Servo Drives (Pulse-train Input Type) have the following features.

Switchable between Two Control Modes

You can switch between two control modes: 1) Position Control Mode and 2) Speed Control Mode. A single Servo Drive enables you to select the suitable mode to support various applications.

Suppressing Vibration of Low-rigidity Mechanisms During Acceleration/Deceleration

The damping control function suppresses vibration of low-rigidity mechanisms or devices whose tips tend to vibrate.

Two damping filters are provided to enable to switch the damping frequency automatically according to the operation direction and via an external signal. In addition, the settings can be configured easily by setting the damping frequency and filter values. You are assured of stable operation even if the set values are inappropriate.

1-2 System Configuration

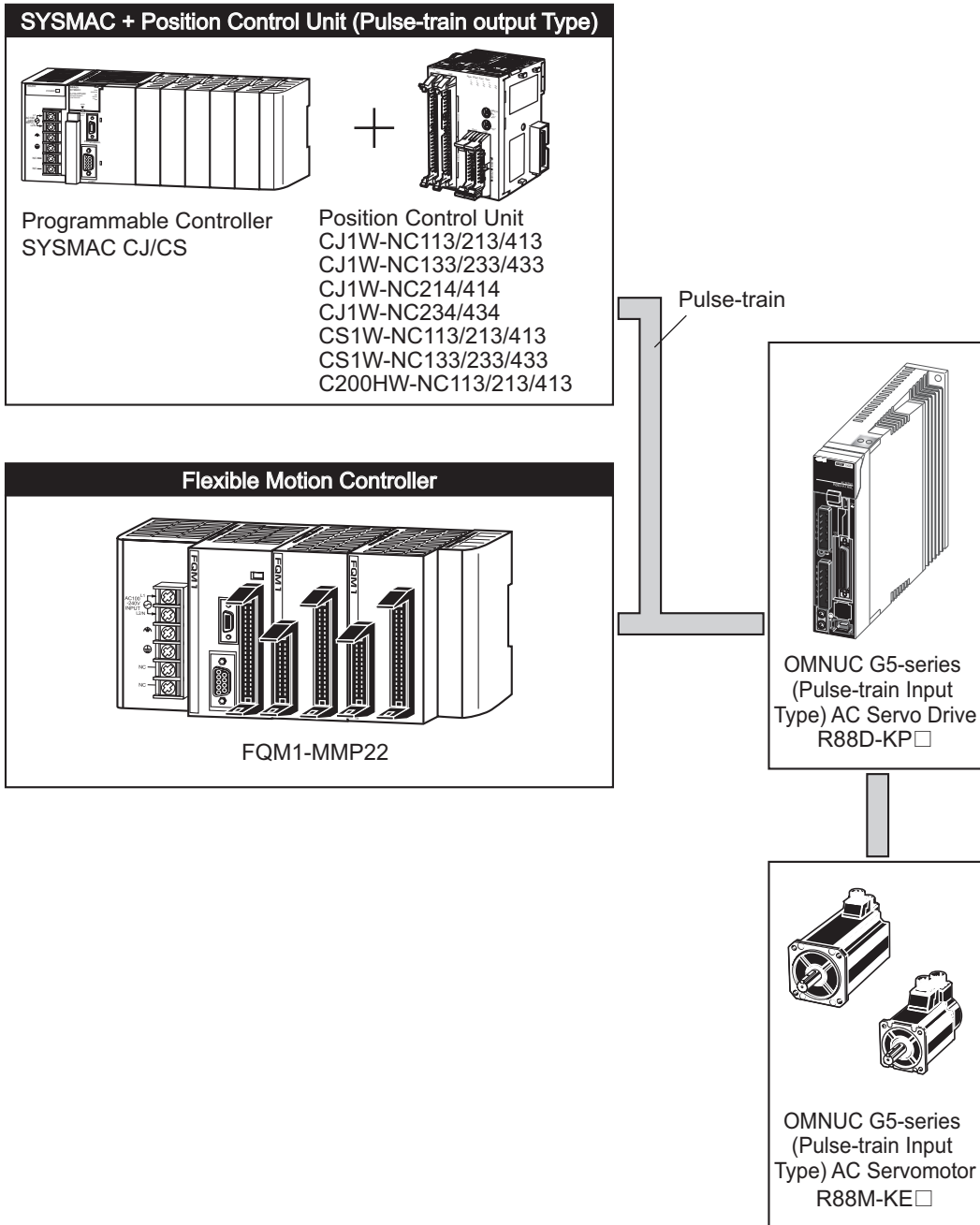

1-3 Names and Functions

1-3-1 Servo Drive Part Names

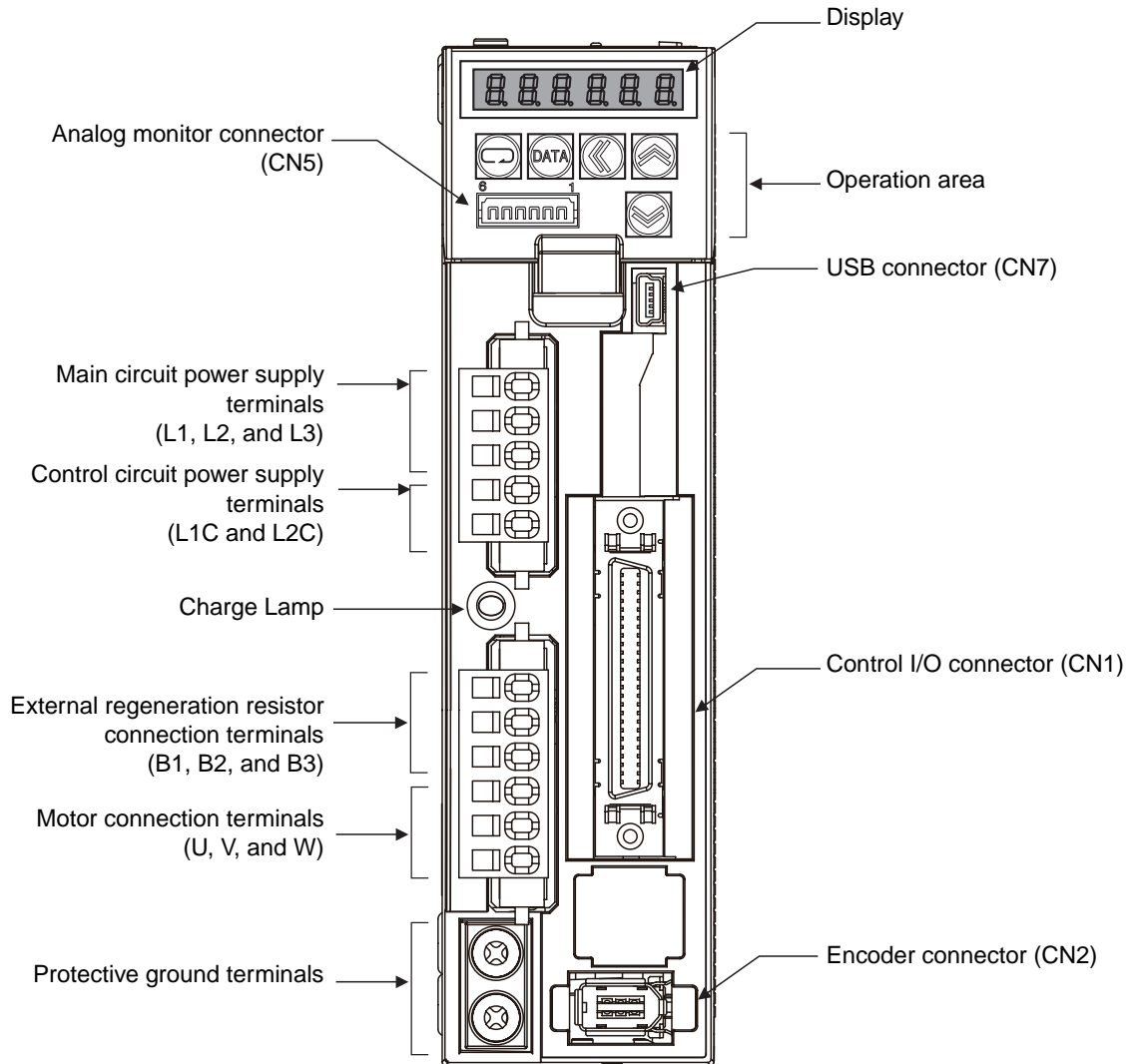

1-3-2 Servo Drive Functions

Display

A 6-digit 7-segment LED display shows the drive status, alarm numbers, parameters, and other information.

Operation Area

This area is used to monitor the parameter settings and drive status.

Charge Lamp

Lights when the main circuit power supply is turned ON.

Control I/O Connector (CN1)

Used for command input signals and I/O signals.

Encoder Connector (CN2)

Connector for the encoder installed in the Servomotor.

Analog Monitor Connector (CN5)

You can use a special cable to monitor values, such as the motor rotation speed, torque command value, etc.

USB Connector (CN7)

Communications connector for the computer.

1-4 System Block Diagram

R88D-KP01H/-KP02H/-KP04H

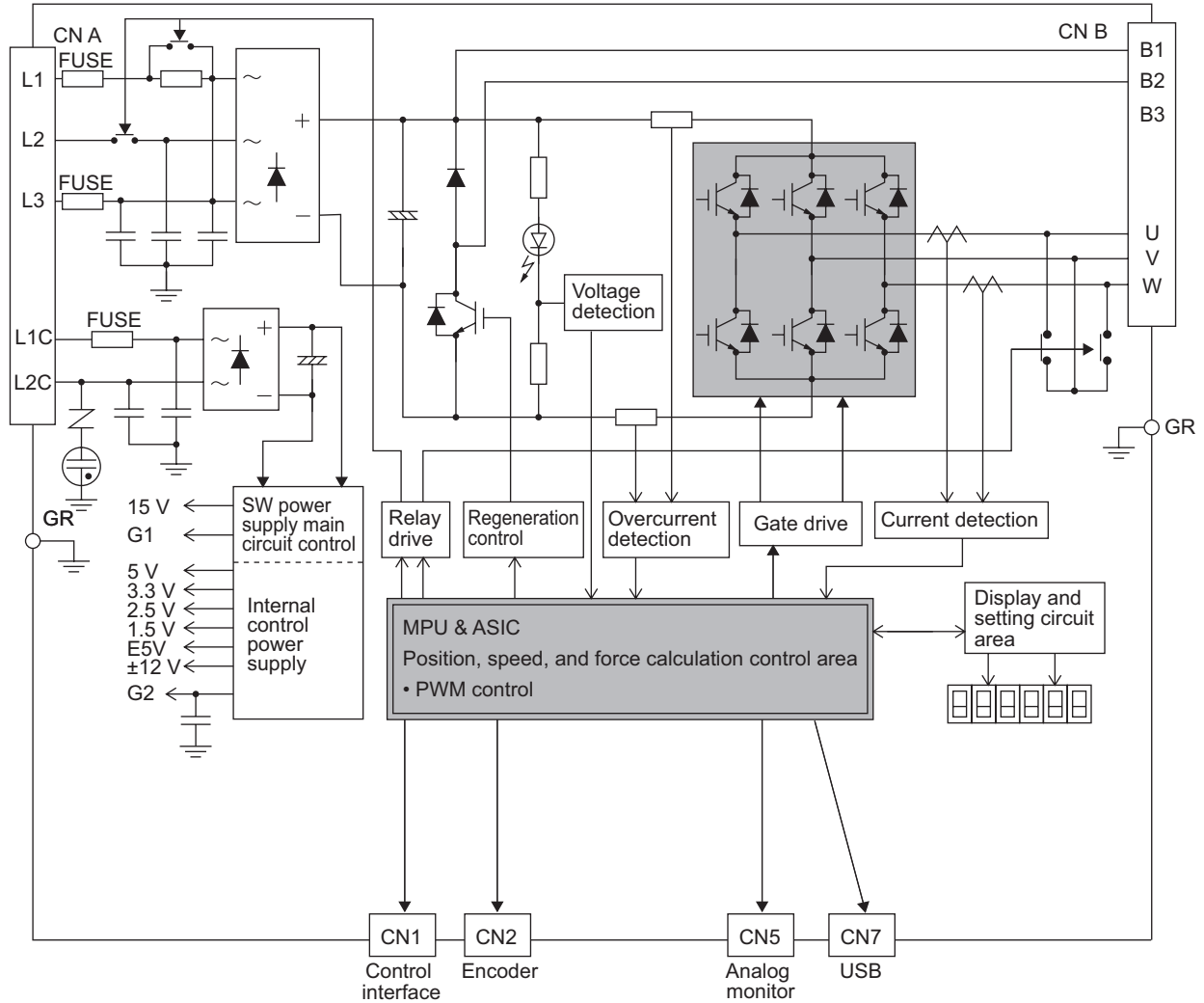

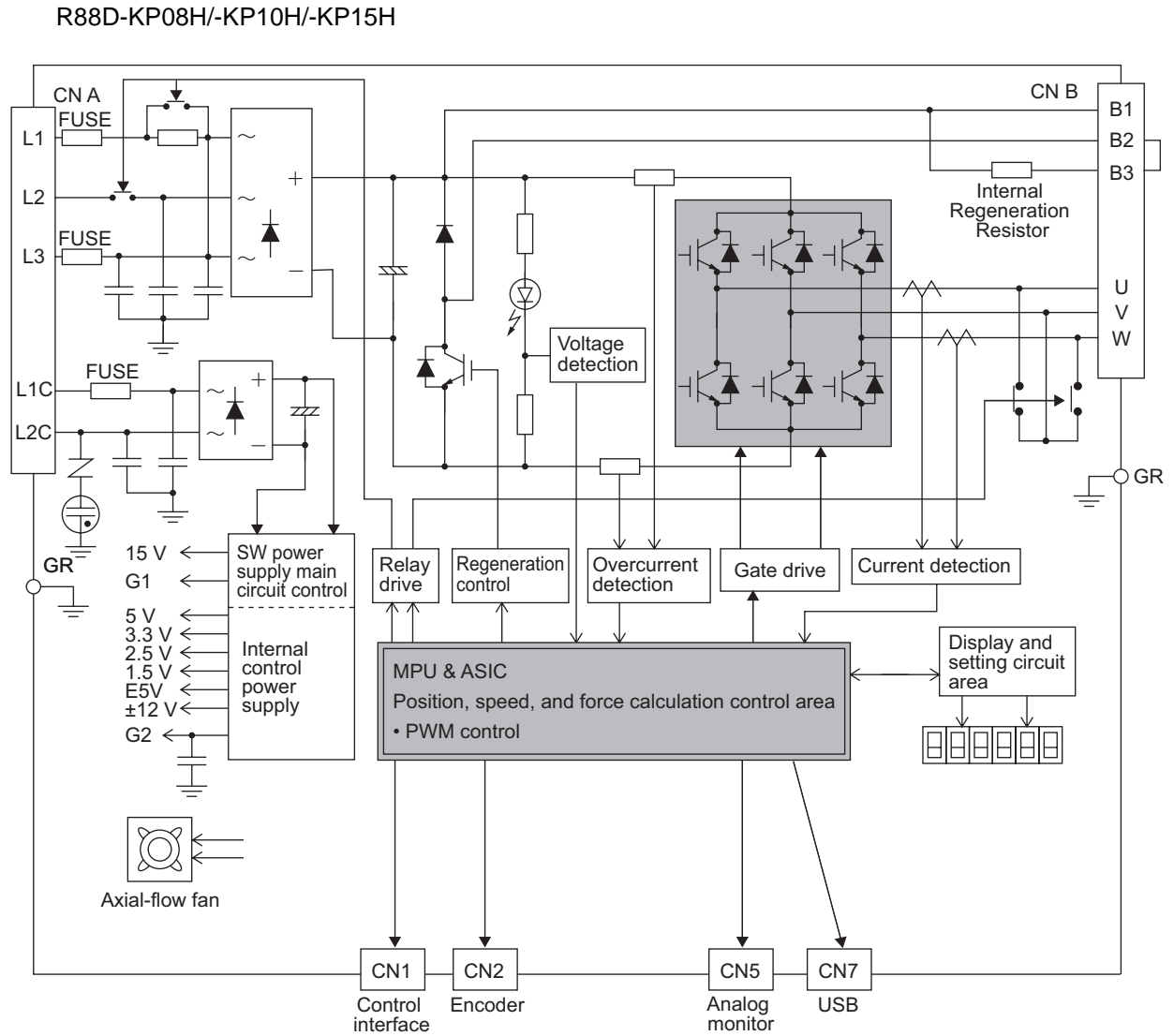

R88D-KP20H

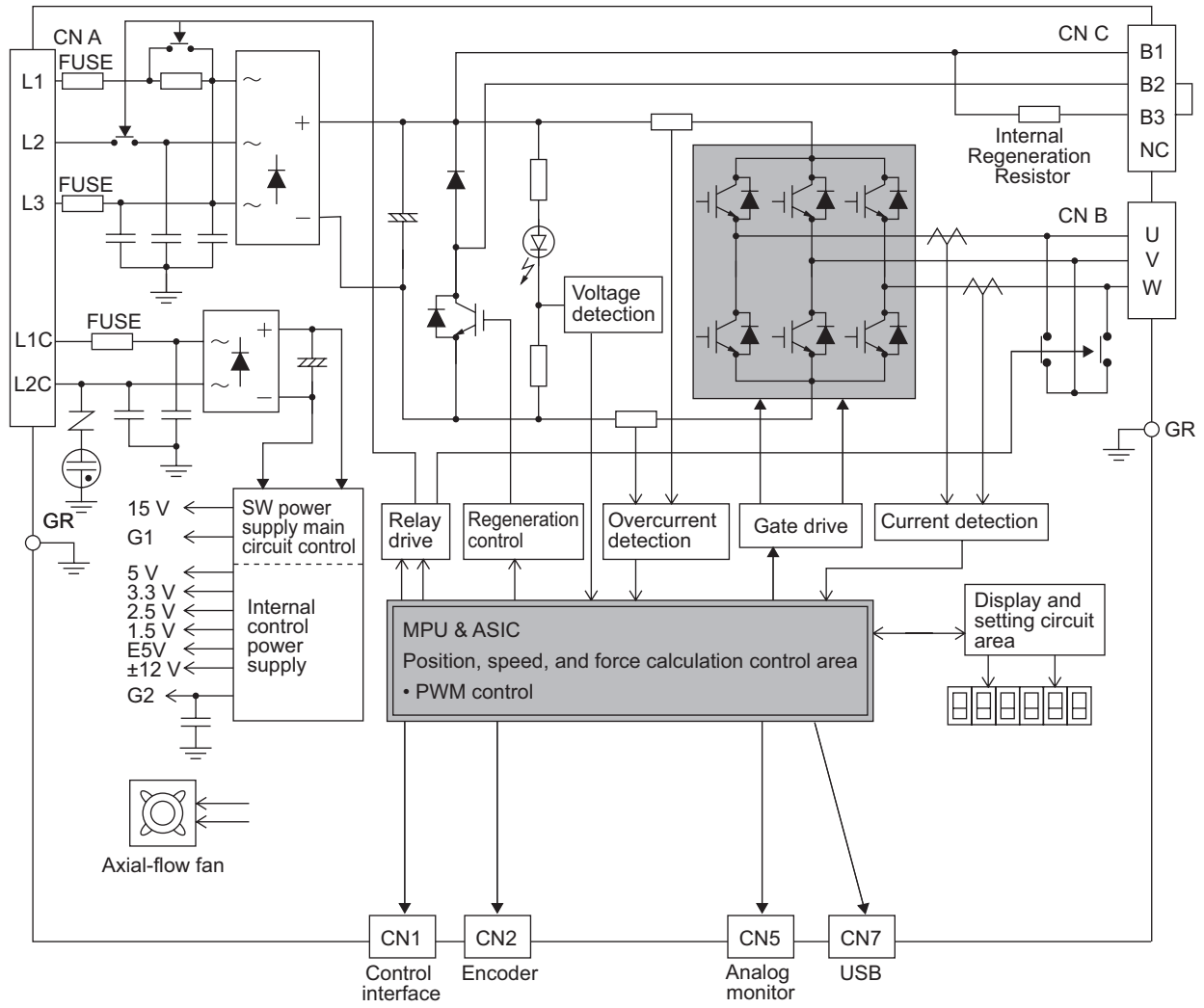

1-5 Applicable Standards

1-5-1 EC Directives

EC directive	Product	Applicable standards
Low Voltage Directive	AC Servo Drives	EN61800-5-1
	AC Servomotors	EN60034-1/-5
EMC Directive	AC Servo Drives	EN55011 class A group1
		IEC61800-3
		EN61000-6-2

Note To conform to EMC Directives, the Servomotor and Servo Drive must be installed under the conditions described in *4-3 Wiring Conforming to EMC Directives* on page 4-20.

1-5-2 UL and cUL Standards

Standard	Product	Applicable standards	File number
UL standards	AC Servo Drives	UL508C	E179149
	AC Servomotors	UL1004-1	E331224
CSA standards	AC Servo Drives	CSA22.2 No.14	E179149
	AC Servomotors	CSA22.2 No.100	E331224

1-5-3 SEMI F47

- Servo Drives conform to the SEMI F47 standard for momentary power interruptions (voltage sag immunity) for no-load or light-load operation.
- This standard applies to semiconductor manufacturing equipment.

Note 1 It does not apply to Servo Drives with 24 VDC specifications for the control power input.
2 Always perform evaluation testing for SEMI F47 compliance in the actual system.

2

Models and External Dimensions

This section explains the models of Servo Drives, Servomotors, Decelerators, and peripheral devices, and provides the external dimensions and mounting dimensions.

2-1	Servo System Configuration	2-2
2-2	How to Read Model Numbers	2-4
2-2-1	Servo Drive	2-4
2-2-2	Servomotor	2-5
2-2-3	Decelerator (Backlash: 3 Arcminutes max.)	2-6
2-2-4	Decelerator (Backlash: 15 Arcminutes max.)	2-7
2-3	Model Tables	2-8
2-3-1	Servo Drive Model Table	2-8
2-3-2	Servomotor Model Tables	2-8
2-3-3	Servo Drive and Servomotor Combination Tables	2-11
2-3-4	Decelerator Model Tables	2-12
2-3-5	Cable and Peripheral Device Model Tables	2-16
2-4	External and Mounting Dimensions	2-22
2-4-1	Servo Drive Dimensions	2-22
2-4-2	Servomotor Dimensions	2-31
2-4-3	Combinations of Servomotors and Decelerators	2-40
2-4-4	Decelerator Dimensions	2-42
2-4-5	External Regeneration Resistor Dimensions	2-56
2-4-6	Reactor Dimensions	2-57
2-4-7	Mounting Bracket (L-brackets for Rack Mounting) Dimensions	2-61

2-1 Servo System Configuration

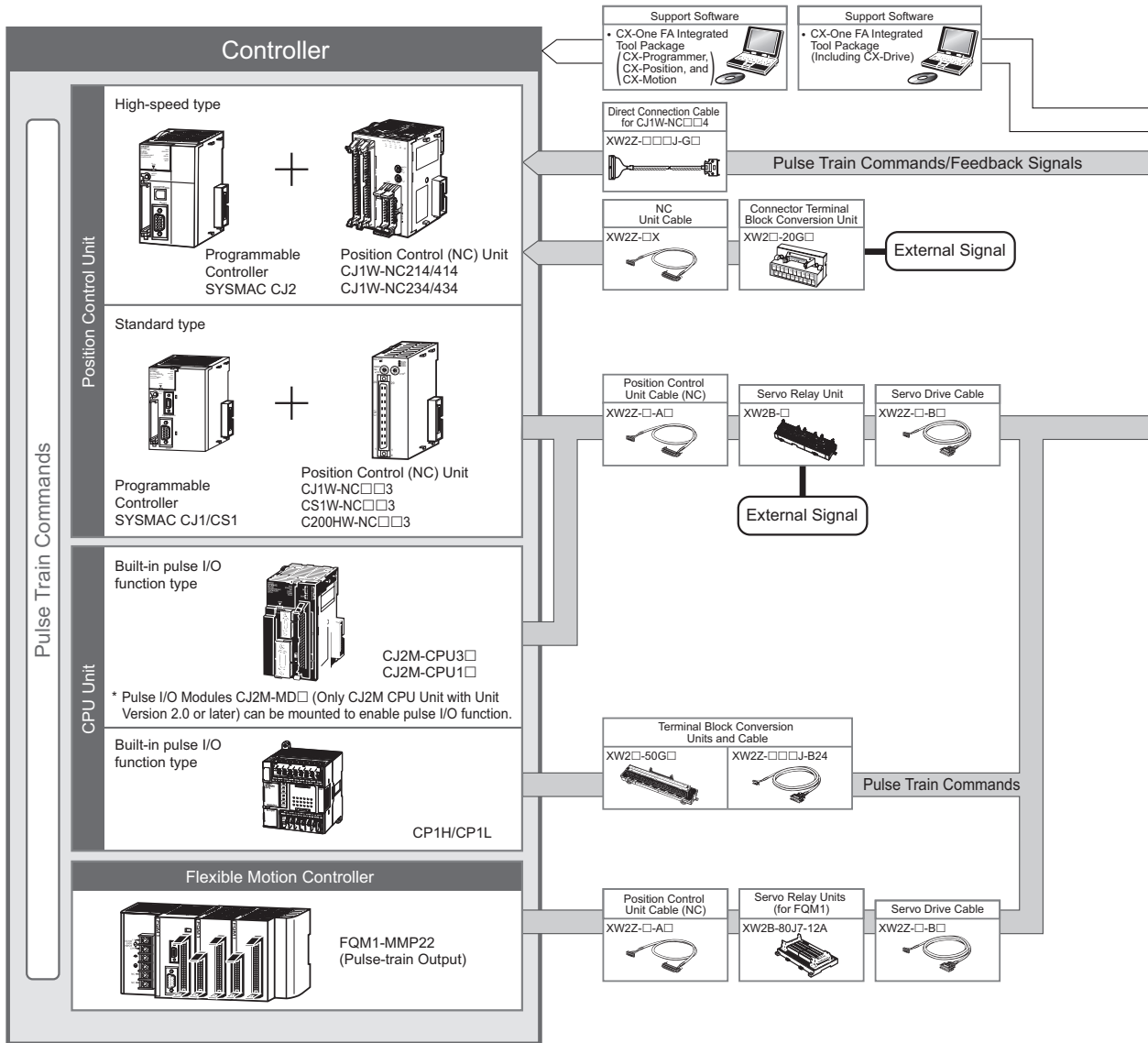

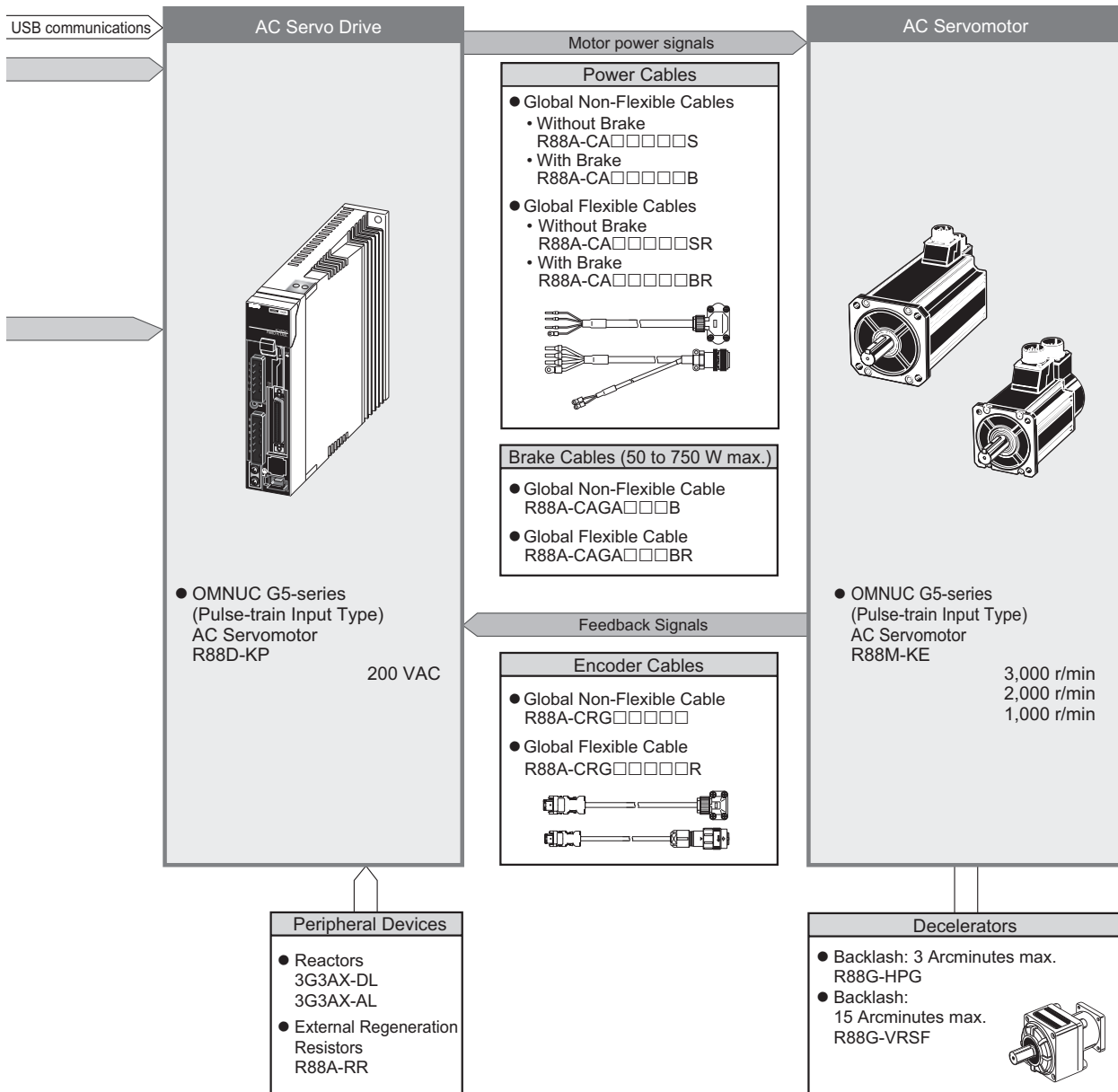

2-2 How to Read Model Numbers

2-2-1 Servo Drive

The Servo Drive model number tells the Servo Drive type, applicable Servomotor capacity, power supply voltage, etc.

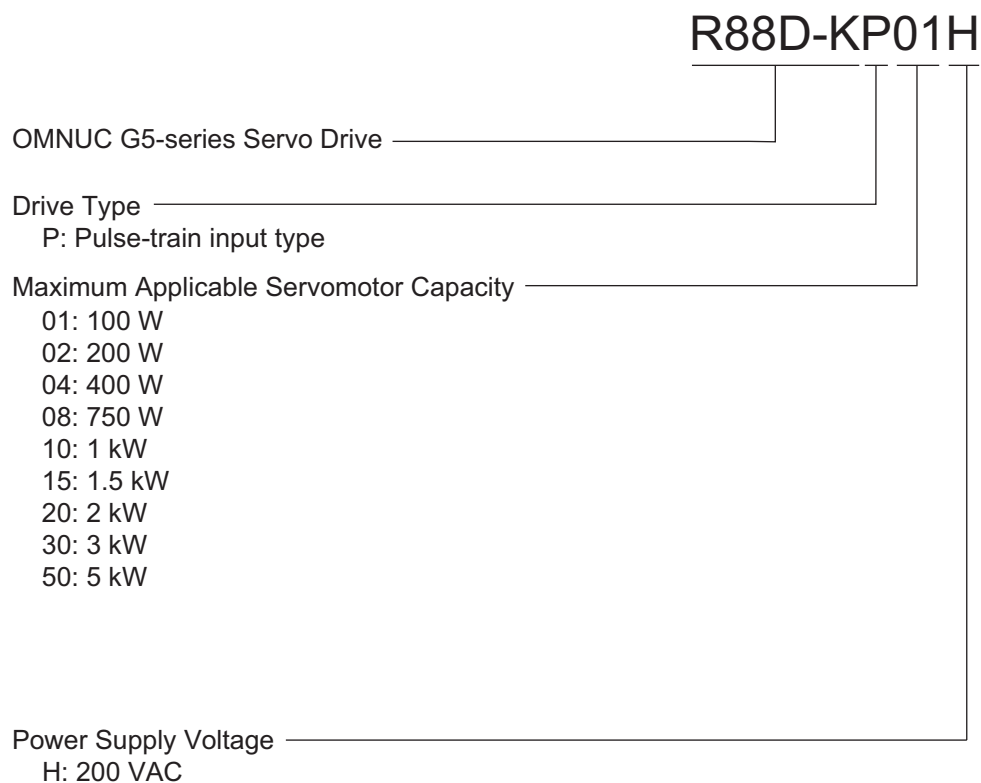

2-2-2 Servomotor

R88M-KE10030H-BOS2

OMNUC G5-series Servomotor

Motor Type

E: Economy type

Servomotor Capacity

- 050 : 50 W
- 100 : 100 W
- 200 : 200 W
- 400 : 400 W
- 750 : 750 W
- 900 : 900 W
- 1K0 : 1 kW
- 1K5 : 1.5 kW
- 2K0 : 2 kW
- 3K0 : 3 kW
- 4K0 : 4 kW
- 5K0 : 5 kW

Rated Rotation Speed

- 10: 1,000 r/min
- 20: 2,000 r/min
- 30: 3,000 r/min

Applied Voltage

H: 200 VAC

Options

- Blank: Straight shaft
- B: With brake
- O: With oil seal
- S2: With key and tap

2-2-3 Decelerator (Backlash: 3 Arcminutes max.)

R88G-HPG14A05100SBJ

Decelerator for G5-Series Servomotor
Backlash: 3 Arcminutes max.

Flange Size Number

- 11B: □40
- 14A: □60
- 20A: □90
- 32A: □120
- 50A: □170
- 65A: □230

Gear Ratio

- 05: 1/5
- 09: 1/9 (only for flange number 11A)
- 11: 1/11 (except for flange number 65A)
- 20: 1/20 (only for flange number 65A)
- 21: 1/21 (except for flange number 65A)
- 25: 1/25 (only for flange number 65A)
- 33: 1/33
- 45: 1/45

Applicable Servomotor Capacity

- 050: 50 W
- 100: 100 W
- 200: 200 W
- 400: 400 W
- 750: 750 W
- 900: 900 W
- 1K0: 1 kW
- 1K5: 1.5 kW
- 2K0: 2 kW
- 3K0: 3 kW
- 4K0: 4 kW
- 5K0: 5 kW

Servomotor Type

- No: 3,000-r/min Cylinder type
- S: 2,000-r/min Servomotors
- T: 1,000-r/min Servomotors

Backlash

- B: 3 Arcminutes max.

Options

- Blank: Straight shaft
- J: With key

2-2-4 Decelerator (Backlash: 15 Arcminutes max.)

R88G-VRSF09B100CJ

Decelerator for G5-Series Servomotor
Backlash: 15 Arcminutes max.

Gear Ratio
05: 1/5
09: 1/9
15: 1/15
25: 1/25

Flange Size Number
B: □52
C: □78
D: □98

Applicable Servomotor Capacity
050: 50 W
100: 100 W
200: 200 W
400: 400 W
750: 750 W

Backlash
C: 15 Arcminutes max.

Options
J: With key

2-3 Model Tables

2-3-1 Servo Drive Model Table

Specifications		Model
Single-phase/3-phase 200 VAC	100 W	R88D-KP01H
	200 W	R88D-KP02H
	400 W	R88D-KP04H
	750 W	R88D-KP08H
	1 kW	R88D-KP10H
	1.5 kW	R88D-KP15H
3-phase 200 VAC	2 kW	R88D-KP20H
	3 kW	R88D-KP30H
	5 kW	R88D-KP50H

2-3-2 Servomotor Model Tables

3,000-r/min Servomotors

- Without brake

Specifications		Model	
		With incremental encoder	
		Straight shaft without key	Straight shaft with key and tap
200 V	50 W	R88M-KE05030H	R88M-KE05030H-S2
	100 W	R88M-KE10030H	R88M-KE10030H-S2
	200 W	R88M-KE20030H	R88M-KE20030H-S2
	400 W	R88M-KE40030H	R88M-KE40030H-S2
	750 W	R88M-KE75030H	R88M-KE75030H-S2
	1 kW	R88M-KE1K030H	R88M-KE1K030H-S2
	1.5 kW	R88M-KE1K530H	R88M-KE1K530H-S2
	2 kW	R88M-KE2K030H	R88M-KE2K030H-S2
	3 kW	R88M-KE3K030H	R88M-KE3K030H-S2
	4 kW	R88M-KE4K030H	R88M-KE4K030H-S2
	5 kW	R88M-KE5K030H	R88M-KE5K030H-S2

Note Models with oil seals are also available.

● With brake

Specifications		Model	
		With incremental encoder	
		Straight shaft without key	Straight shaft with key and tap
200 V	50 W	R88M-KE05030H-B	R88M-KE05030H-BS2
	100 W	R88M-KE10030H-B	R88M-KE10030H-BS2
	200 W	R88M-KE20030H-B	R88M-KE20030H-BS2
	400 W	R88M-KE40030H-B	R88M-KE40030H-BS2
	750 W	R88M-KE75030H-B	R88M-KE75030H-BS2
	1 kW	R88M-KE1K030H-B	R88M-KE1K030H-BS2
	1.5 kW	R88M-KE1K530H-B	R88M-KE1K530H-BS2
	2 kW	R88M-KE2K030H-B	R88M-KE2K030H-BS2
	3 kW	R88M-KE3K030H-B	R88M-KE3K030H-BS2
	4 kW	R88M-KE4K030H-B	R88M-KE4K030H-BS2
5 kW	R88M-KE5K030H-B	R88M-KE5K030H-BS2	

Note Models with oil seals are also available.

2,000-r/min Servomotors

● Without brake

Specifications		Model	
		With incremental encoder	
		Straight shaft without key	Straight shaft with key and tap
200 V	1 kW	R88M-KE1K020H	R88M-KE1K020H-S2
	1.5 kW	R88M-KE1K520H	R88M-KE1K520H-S2
	2 kW	R88M-KE2K020H	R88M-KE2K020H-S2
	3 kW	R88M-KE3K020H	R88M-KE3K020H-S2
	4 kW	R88M-KE4K020H	R88M-KE4K020H-S2
	5 kW	R88M-KE5K020H	R88M-KE5K020H-S2

Note Models with oil seals are also available.

● With brake

Specifications		Model	
		With incremental encoder	
		Straight shaft without key	Straight shaft with key and tap
200 V	1 kW	R88M-KE1K020H-B	R88M-KE1K020H-BS2
	1.5 kW	R88M-KE1K520H-B	R88M-KE1K520H-BS2
	2 kW	R88M-KE2K020H-B	R88M-KE2K020H-BS2
	3 kW	R88M-KE3K020H-B	R88M-KE3K020H-BS2
	4 kW	R88M-KE4K020H-B	R88M-KE4K020H-BS2
	5 kW	R88M-KE5K020H-B	R88M-KE5K020H-BS2

Note Models with oil seals are also available.

1,000-r/min Servomotors

● Without brake

Specifications		Model	
		With incremental encoder	
		Straight shaft without key	Straight shaft with key and tap
200 V	900 W	R88M-KE90010H	R88M-KE90010H-S2
	2 kW	R88M-KE2K010H	R88M-KE2K010H-S2
	3 kW	R88M-KE3K010H	R88M-KE3K010H-S2

● With brake

Specifications		Model	
		With incremental encoder	
		Straight shaft without key	Straight shaft with key and tap
200 V	900 W	R88M-KE90010H-B	R88M-KE90010H-BS2
	2 kW	R88M-KE2K010H-B	R88M-KE2K010H-BS2
	3 kW	R88M-KE3K010H-B	R88M-KE3K010H-BS2

Note Models with oil seals are also available.

2-3-3 Servo Drive and Servomotor Combination Tables

The tables in this section show the possible combinations of OMNUC G5-series (Pulse-train Input Type) Servo Drives and Servomotors. The Servomotors and Servo Drives can only be used in the listed combinations.

“-□” at the end of the motor model number is for options, such as the shaft type, brake, oil seal and key.

3,000-r/min Servomotors and Servo Drives

Voltage	Servomotor		Servo Drive
	Rated output	With incremental encoder	
Single-phase/ 3-phase 200 V	50 W ^{*1}	R88M-KE05030H-□	R88D-KP01H
	100 W	R88M-KE10030H-□	R88D-KP01H
	200 W	R88M-KE20030H-□	R88D-KP02H
	400 W	R88M-KE40030H-□	R88D-KP04H
	750 W	R88M-KE75030H-□	R88D-KP08H
	1 kW ^{*1}	R88M-KE1K030H-□	R88D-KP15H
	1.5 kW	R88M-KE1K530H-□	R88D-KP15H
3-phase 200 V	2 kW	R88M-KE2K030H-□	R88D-KP20H
	3 kW	R88M-KE3K030H-□	R88D-KP30H
	4 kW ^{*1}	R88M-KE4K030H-□	R88D-KP50H
	5 kW	R88M-KE5K030H-□	R88D-KP50H

*1 Use these combination with caution because the Servo Drive and Servomotor have different capacities.

2,000-r/min Servomotors and Servo Drives

Voltage	Servomotor		Servo Drive
	Rated output	With incremental encoder	
Single-phase/ 3-phase 200 V	1 kW	R88M-KE1K020H-□	R88D-KP10H
	1.5 kW	R88M-KE1K520H-□	R88D-KP15H
3-phase 200 V	2 kW	R88M-KE2K020H-□	R88D-KP20H
	3 kW	R88M-KE3K020H-□	R88D-KP30H
	4 kW ^{*1}	R88M-KE4K020H-□	R88D-KP50H
	5 kW	R88M-KE5K020H-□	R88D-KP50H

*1 Use these combination with caution because the Servo Drive and Servomotor have different capacities.

1,000-r/min Servomotors and Servo Drives

Voltage	Servomotor		Servo Drive
	Rated output	With incremental encoder	
Single-phase/ 3-phase 200 V	900 W ^{*1}	R88M-KE90010H-□	R88D-KP15H
3-phase 200 V	2 kW ^{*1}	R88M-KE2K010H-□	R88D-KP30H
	3 kW ^{*1}	R88M-KE3K010H-□	R88D-KP50H

*1 Use these combination with caution because the Servo Drive and Servomotor have different capacities.

2-3-4 Decelerator Model Tables

The following tables list the Decelerator models for OMNUC G5-series Servomotors. Select a decelerator based on the Servomotor capacity.

Backlash: 3 Arcminutes max.

● For 3,000-r/min Servomotors

Specifications		Model
Servomotor capacity	Gear ratio	
50 W	1/5	R88G-HPG11B05100B□
	1/9	R88G-HPG11B09050B□
	1/21	R88G-HPG14A21100B□
	1/33	R88G-HPG14A33050B□
	1/45	R88G-HPG14A45050B□
100 W	1/5	R88G-HPG11B05100B□
	1/11	R88G-HPG14A11100B□
	1/21	R88G-HPG14A21100B□
	1/33	R88G-HPG20A33100B□
	1/45	R88G-HPG20A45100B□
200 W	1/5	R88G-HPG14A05200B□
	1/11	R88G-HPG14A11200B□
	1/21	R88G-HPG20A21200B□
	1/33	R88G-HPG20A33200B□
	1/45	R88G-HPG20A45200B□
400 W	1/5	R88G-HPG14A05400B□
	1/11	R88G-HPG20A11400B□
	1/21	R88G-HPG20A21400B□
	1/33	R88G-HPG32A33400B□
	1/45	R88G-HPG32A45400B□
750 W	1/5	R88G-HPG20A05750B□
	1/11	R88G-HPG20A11750B□
	1/21	R88G-HPG32A21750B□
	1/33	R88G-HPG32A33750B□
	1/45	R88G-HPG32A45750B□

Specifications		Model
Servomotor capacity	Gear ratio	
1 kW	1/5	R88G-HPG32A052K0B□
	1/11	R88G-HPG32A112K0B□
	1/21	R88G-HPG32A211K5B□
	1/33	R88G-HPG50A332K0B□
	1/45	R88G-HPG50A451K5B□
1.5 kW	1/5	R88G-HPG32A052K0B□
	1/11	R88G-HPG32A112K0B□
	1/21	R88G-HPG32A211K5B□
	1/33	R88G-HPG50A332K0B□
	1/45	R88G-HPG50A451K5B□
2 kW	1/5	R88G-HPG32A052K0B□
	1/11	R88G-HPG32A112K0B□
	1/21	R88G-HPG50A212K0B□
	1/33	R88G-HPG50A332K0B□
3 kW	1/5	R88G-HPG32A053K0B□
	1/11	R88G-HPG50A113K0B□
	1/21	R88G-HPG50A213K0B□
4 kW	1/5	R88G-HPG32A054K0B□
	1/11	R88G-HPG50A115K0B□
5 kW	1/5	R88G-HPG50A055K0B□
	1/11	R88G-HPG50A115K0B□

Note 1 The standard shaft type is a straight shaft.

2 A model with a key and tap is indicated with J at the end of the model number (the suffix shown in the box).
(Example: R88G-HPG11A05100BJ)

● For 2,000-r/min Servomotors

Specifications		Model
Servomotor capacity	Gear ratio	
1 kW	1/5	R88G-HPG32A053K0B□
	1/11	R88G-HPG32A112K0SB□
	1/21	R88G-HPG32A211K0SB□
	1/33	R88G-HPG50A332K0SB□
	1/45	R88G-HPG50A451K0SB□
1.5 kW	1/5	R88G-HPG32A053K0B□
	1/11	R88G-HPG32A112K0SB□
	1/21	R88G-HPG50A213K0B□
	1/33	R88G-HPG50A332K0SB□
2 kW	1/5	R88G-HPG32A053K0B□
	1/11	R88G-HPG32A112K0SB□
	1/21	R88G-HPG50A213K0B□
	1/33	R88G-HPG50A332K0SB□
3 kW	1/5	R88G-HPG32A054K0B□
	1/11	R88G-HPG50A115K0B□
	1/21	R88G-HPG50A213K0SB□
	1/25	R88G-HPG65A253K0SB□
4 kW	1/5	R88G-HPG50A055K0SB□
	1/11	R88G-HPG50A115K0SB□
	1/20	R88G-HPG65A205K0SB□
	1/25	R88G-HPG65A255K0SB□
5 kW	1/5	R88G-HPG50A055K0SB□
	1/11	R88G-HPG50A115K0SB□
	1/20	R88G-HPG65A205K0SB□
	1/25	R88G-HPG65A255K0SB□

Note 1 The standard shaft type is a straight shaft.

2 A model with a key and tap is indicated with J at the end of the model number (the suffix shown in the box).
(Example: R88G-HPG32A053K0BJ)

● For 1,000-r/min Servomotors

Specifications		Model
Servomotor capacity	Gear ratio	
900 W	1/5	R88G-HPG32A05900TB□
	1/11	R88G-HPG32A11900TB□
	1/21	R88G-HPG50A21900TB□
	1/33	R88G-HPG50A33900TB□
2 kW	1/5	R88G-HPG32A052K0TB□
	1/11	R88G-HPG50A112K0TB□
	1/21	R88G-HPG50A212K0TB□
	1/25	R88G-HPG65A255K0SB□
3 kW	1/5	R88G-HPG50A055K0SB□
	1/11	R88G-HPG50A115K0SB□
	1/20	R88G-HPG65A205K0SB□
	1/25	R88G-HPG65A255K0SB□

Note 1 The standard shaft type is a straight shaft.

2 A model with a key and tap is indicated with J at the end of the model number (the suffix shown in the box).
(Example: R88G-HPG32A05900TBJ)

Backlash: 15 Arcminutes max.

● For 3,000-r/min Servomotors (Straight Shaft with Key)

Specifications		Model
Servomotor capacity	Gear ratio	
50 W	1/5	R88G-VRSF05B100CJ
	1/9	R88G-VRSF09B100CJ
	1/15	R88G-VRSF15B100CJ
	1/25	R88G-VRSF25B100CJ
100 W	1/5	R88G-VRSF05B100CJ
	1/9	R88G-VRSF09B100CJ
	1/15	R88G-VRSF15B100CJ
	1/25	R88G-VRSF25B100CJ
200 W	1/5	R88G-VRSF05B200CJ
	1/9	R88G-VRSF09C200CJ
	1/15	R88G-VRSF15C200CJ
	1/25	R88G-VRSF25C200CJ
400 W	1/5	R88G-VRSF05C400CJ
	1/9	R88G-VRSF09C400CJ
	1/15	R88G-VRSF15C400CJ
	1/25	R88G-VRSF25C400CJ
750 W	1/5	R88G-VRSF05C750CJ
	1/9	R88G-VRSF09D750CJ
	1/15	R88G-VRSF15D750CJ
	1/25	R88G-VRSF25D750CJ

2-3-5 Cable and Peripheral Device Model Tables

Encoder Cables (Global Non-Flexible Cable)

Specifications	Model	
[200 V] For 3,000-r/min Servomotors of 50 to 750 W	3 m	R88A-CRGB003C
	5 m	R88A-CRGB005C
	10 m	R88A-CRGB010C
	15 m	R88A-CRGB015C
	20 m	R88A-CRGB020C
[200 V] 3,000-r/min Servomotors of 1.0 kW or more For 2,000-r/min Servomotors For 1,000-r/min Servomotors	3 m	R88A-CRGC003N
	5 m	R88A-CRGC005N
	10 m	R88A-CRGC010N
	15 m	R88A-CRGC015N
	20 m	R88A-CRGC020N

Motor Power Cables (Global Non-Flexible Cable)

Specifications	Model		
	For motor without brake	For motor with brake	
[200 V] For 3,000-r/min Servomotors of 50 to 750 W	3 m	R88A-CAGA003S	–
	5 m	R88A-CAGA005S	–
	10 m	R88A-CAGA010S	–
	15 m	R88A-CAGA015S	–
	20 m	R88A-CAGA020S	–
For 3,000-r/min Servomotors of 1 to 2 kW For 2,000-r/min Servomotors of 1 to 2 kW For 1,000-r/min Servomotors of 900 W	3 m	R88A-CAGB003S	R88A-CAGB003B
	5 m	R88A-CAGB005S	R88A-CAGB005B
	10 m	R88A-CAGB010S	R88A-CAGB010B
	15 m	R88A-CAGB015S	R88A-CAGB015B
	20 m	R88A-CAGB020S	R88A-CAGB020B
For 3,000-r/min Servomotors of 3 to 5 kW For 2,000-r/min Servomotors of 3 to 5 kW For 1,000-r/min Servomotors of 2 to 3 kW	3 m	R88A-CAGD003S	R88A-CAGD003B
	5 m	R88A-CAGD005S	R88A-CAGD005B
	10 m	R88A-CAGD010S	R88A-CAGD010B
	15 m	R88A-CAGD015S	R88A-CAGD015B
	20 m	R88A-CAGD020S	R88A-CAGD020B

Brake Cables (Global Non-Flexible Cable)

Specifications	Model	
[200 V] For 3,000-r/min Servomotors of 50 to 750 W	3 m	R88A-CAGA003B
	5 m	R88A-CAGA005B
	10 m	R88A-CAGA010B
	15 m	R88A-CAGA015B
	20 m	R88A-CAGA020B

Encoder Cables (Global Flexible Cable)

Specifications	Model	
[200 V] For 3,000-r/min Servomotors of 50 to 750 W	3 m	R88A-CRGB003CR
	5 m	R88A-CRGB005CR
	10 m	R88A-CRGB010CR
	15 m	R88A-CRGB015CR
	20 m	R88A-CRGB020CR
[200 V] 3,000-r/min Servomotors of 1.0 kW or more For 2,000-r/min Servomotors For 1,000-r/min Servomotors	3 m	R88A-CRGC003NR
	5 m	R88A-CRGC005NR
	10 m	R88A-CRGC010NR
	15 m	R88A-CRGC015NR
	20 m	R88A-CRGC020NR

Motor Power Cables (Global Flexible Cable)

Specifications	Model		
		For motor without brake	For motor with brake
[200 V] For 3,000-r/min Servomotors of 50 to 750 W	3 m	R88A-CAGA003SR	—
	5 m	R88A-CAGA005SR	—
	10 m	R88A-CAGA010SR	—
	15 m	R88A-CAGA015SR	—
	20 m	R88A-CAGA020SR	—
[200 V] For 3,000-r/min Servomotors of 1 to 2 kW For 2,000-r/min Servomotors of 1 to 2 kW For 1,000-r/min Servomotors of 900 W	3 m	R88A-CAGB003SR	R88A-CAGB003BR
	5 m	R88A-CAGB005SR	R88A-CAGB005BR
	10 m	R88A-CAGB010SR	R88A-CAGB010BR
	15 m	R88A-CAGB015SR	R88A-CAGB015BR
	20 m	R88A-CAGB020SR	R88A-CAGB020BR
For 3,000-r/min Servomotors of 3 to 5 kW For 2,000-r/min Servomotors of 3 to 5 kW For 1,000-r/min Servomotors of 2 to 3 kW	3 m	R88A-CAGD003SR	R88A-CAGD003BR
	5 m	R88A-CAGD005SR	R88A-CAGD005BR
	10 m	R88A-CAGD010SR	R88A-CAGD010BR
	15 m	R88A-CAGD015SR	R88A-CAGD015BR
	20 m	R88A-CAGD020SR	R88A-CAGD020BR

Note Different connectors are used for the motor power and the brake on 200-V 3,000-r/min Servomotors of 50 to 750 W. When using a Servomotor with a brake, two cables are required: a Power Cable without Brake and a Brake Cable.

Brake Cables (Global Flexible Cable)

Specifications	Model	
[200 V] For 3,000-r/min Servomotors of 50 to 750 W	3 m	R88A-CAGA003BR
	5 m	R88A-CAGA005BR
	10 m	R88A-CAGA010BR
	15 m	R88A-CAGA015BR
	20 m	R88A-CAGA020BR

Analog Monitor Cable

Specifications		Model
Analog Monitor Cable	1 m	R88A-CMK001S

Connectors

Specifications		Model
Motor Connector for Encoder Cable	[200 V] For 3,000-r/min of 50 to 750 W	R88A-CNG02R
Control I/O Connector (CN1)		R88A-CNU11C
Encoder Connector (CN2)		R88A-CNW01R
Power Cable Connector (for 750 W max.)		R88A-CNG01A
Brake Cable Connector (for 750 W max.)		R88A-CNG01B

Servo Relay Units (for CN1)

Specifications		Model
Servo Relay Unit	For CS1W-NC113/-NC133 For CJ1W-NC113/-NC133 For C200HW-NC113	XW2B-20J6-1B
	For CS1W-NC213/-NC413/-NC233/-NC433 For CJ1W-NC213/-NC413/-NC233/-NC433 For C200HW-NC213/-NC413	XW2B-40J6-2B
	For CJ2M-CPU31/-CPU32/-CPU33/-CPU34/-CPU35 For CJ2M-CPU11/-CPU12/-CPU13/-CPU14/-CPU15	XW2B-20J6-8A XW2B-40J6-9A
	For FQM1-MMP22	XW2B-80J7-12A
	For CQM1-CPU43-V1	XW2B-20J6-3B

Servo Relay Unit Cables (Servo Drive)

Specifications		Model	
Servo Drive Cable	For NC Unit (XW2B-□J6-□B)	1 m	XW2Z-100J-B25
	For CQM1 (XW2B-20J6-3B)	2 m	XW2Z-200J-B25
	For CJ2M-CPU31/-CPU32/-CPU33/-CPU34/-CPU35 For CJ2M-CPU11/-CPU12/-CPU13/-CPU14/-CPU15 (XW2B-20J6-8A/XW2B-40J6-9A)	1 m	XW2Z-100J-B31
		2 m	XW2Z-200J-B31
	For FQM1-MMP22 (XW2B-80J7-12A)	1 m	XW2Z-100J-B26
		2 m	XW2Z-200J-B26

Servo Relay Unit Cables (Position Control Unit)

Specifications		Model		
Position Control Unit Cable	For CS1W-NC113, C200HW-NC113 (XW2B-20J6-1B)	0.5 m	XW2Z-050J-A6	
		1 m	XW2Z-100J-A6	
	For CS1W-NC213/-NC413, C200HW-NC213/-NC413 (XW2B-20J6-2B)	0.5 m	XW2Z-050J-A7	
		1 m	XW2Z-100J-A7	
	For CS1W-NC133 (XW2B-20J6-1B)	0.5 m	XW2Z-050J-A10	
		1 m	XW2Z-100J-A10	
	For CS1W-NC233/-NC433 (XW2B-20J6-2B)	0.5 m	XW2Z-050J-A11	
		1 m	XW2Z-100J-A11	
	For CJ1W-NC113 (XW2B-20J6-1B)	0.5 m	XW2Z-050J-A14	
		1 m	XW2Z-100J-A14	
	For CJ1W-NC213/-NC413 (XW2B-20J6-2B)	0.5 m	XW2Z-050J-A15	
		1 m	XW2Z-100J-A15	
	For CJ1W-NC133 (XW2B-20J6-1B)	0.5 m	XW2Z-050J-A18	
		1 m	XW2Z-100J-A18	
	For CJ1W-NC233/-NC433 (XW2B-20J6-2B)	0.5 m	XW2Z-050J-A19	
		1 m	XW2Z-100J-A19	
	For CJ2M-CPU31/-CPU32/-CPU33/-CPU34/-CPU35 For CJ2M-CPU11/-CPU12/-CPU13/-CPU14/-CPU15 (XW2B-20J6-8A/XW2B-40J6-9A)	0.5 m	XW2Z-050J-A33	
		1 m	XW2Z-100J-A33	
	For FQM1-MMP22 (XW2B-80J7-12A)	General-Purpose I/O	0.5 m	XW2Z-050J-A28
			1 m	XW2Z-100J-A28
2 m			XW2Z-200J-A28	
Special I/O		0.5 m	XW2Z-050J-A30	
		1 m	XW2Z-100J-A30	
		2 m	XW2Z-200J-A30	

Control Cables

Specifications		Model
Specified cables for Position Control Unit (for line driver output 1 axis) CJ1W-NC234/-NC434	1 m	XW2Z-100J-G9
	5 m	XW2Z-500J-G9
	10 m	XW2Z-10MJ-G9
Specified cables for Position Control Unit (for open collector output 1 axis) CJ1W-NC214/-NC414	1 m	XW2Z-100J-G13
	3 m	XW2Z-300J-G13
Specified cables for Position Control Unit (for line driver output 2 axes) CJ1W-NC234/-NC434	1 m	XW2Z-100J-G1
	5 m	XW2Z-500J-G1
	10 m	XW2Z-10MJ-G1
Specified cables for Position Control Unit (for open collector output 2 axes) CJ1W-NC214/-NC414	1 m	XW2Z-100J-G5
	3 m	XW2Z-300J-G5
General-purpose Control Cables (with connector on one end)	1 m	R88A-CPG001S
	2 m	R88A-CPG002S
Connector Terminal Block Cables	1 m	XW2Z-100J-B24
	2 m	XW2Z-200J-B24
Connector Terminal Block	M3 screws	XW2B-50G4
	M3.5 screws	XW2B-50G5
	M3 screws	XW2D-50G6

External Regeneration Resistors

Specifications	Model
Regeneration process capacity: 20 W, 50 Ω (with 150°C thermal sensor)	R88A-RR08050S
Regeneration process capacity: 20 W, 100 Ω (with 150°C thermal sensor)	R88A-RR080100S
Regeneration process capacity: 70 W, 47 Ω (with 170°C thermal sensor)	R88A-RR22047S
Regeneration process capacity: 70 W, 47 Ω (with 150°C thermal sensor)	R88A-RR22047S1
Regeneration process capacity: 180 W, 20 Ω (with 200°C thermal sensor)	R88A-RR50020S

Reactors

Specifications	Model	Reactor type
R88D-KP01H (For single-phase input)	3G3AX-DL2002	DC reactor
R88D-KP02H (For single-phase input)	3G3AX-DL2004	
R88D-KP04H (For single-phase input)	3G3AX-DL2007	
R88D-KP08H/-KP10H (For single-phase input)	3G3AX-DL2015	
R88D-KP15H (For single-phase input)	3G3AX-DL2022	
R88D-KP01H/-KP02H/-KP04H/ -KP08H/-KP10H/-KP15H (For 3-phase input)	3G3AX-AL2025	AC reactor
R88D-KP20H/-KP30H	3G3AX-AL2055	
R88D-KP50H	3G3AX-AL2110	

Mounting Brackets (L-brackets for Rack Mounting)

Specifications	Model
R88D-KP01H/-KP02H	R88A-TK01K
R88D-KP04H	R88A-TK02K
R88D-KP08H	R88A-TK03K
R88D-KP10H/-KP15H	R88A-TK04K

2-4 External and Mounting Dimensions

2-4-1 Servo Drive Dimensions

Single-phase/3-phase 200 VAC: R88D-KP01H/-KP02H (100 to 200 W)

- Wall Mounting

External Dimensions

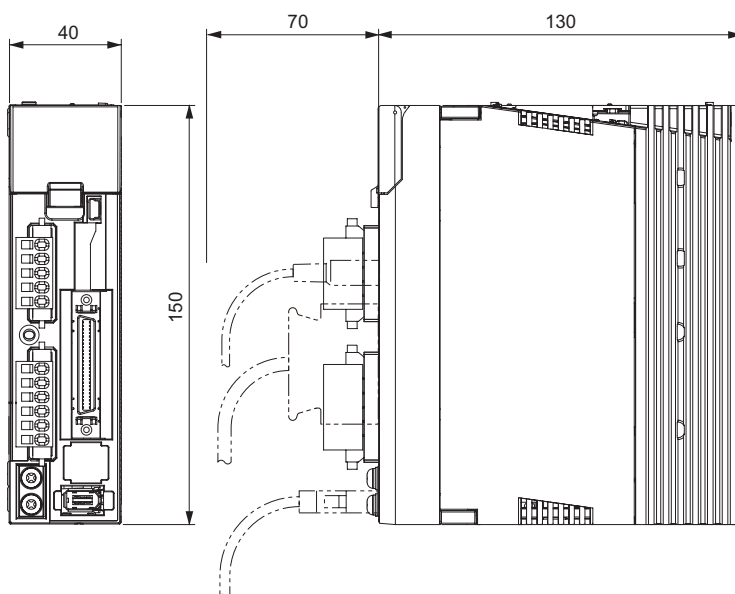

Mounting dimensions

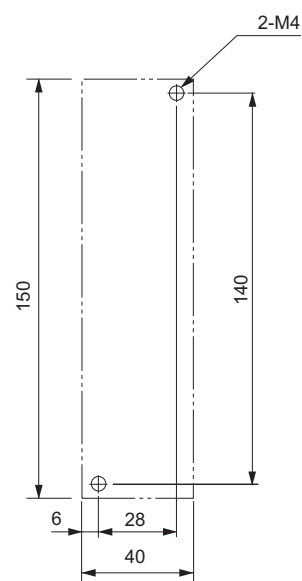

● Front Mounting (Using Front Mounting Brackets)

External Dimensions

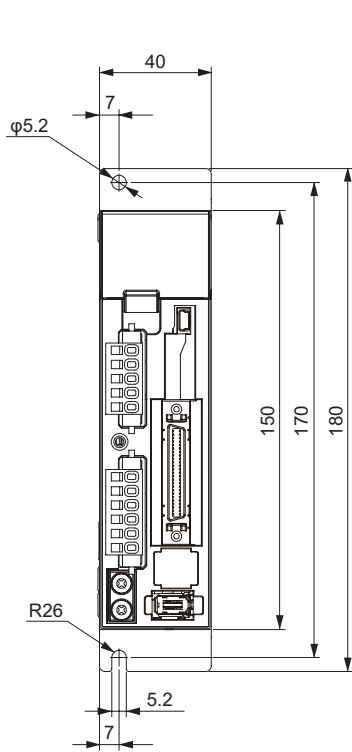

Mounting dimensions

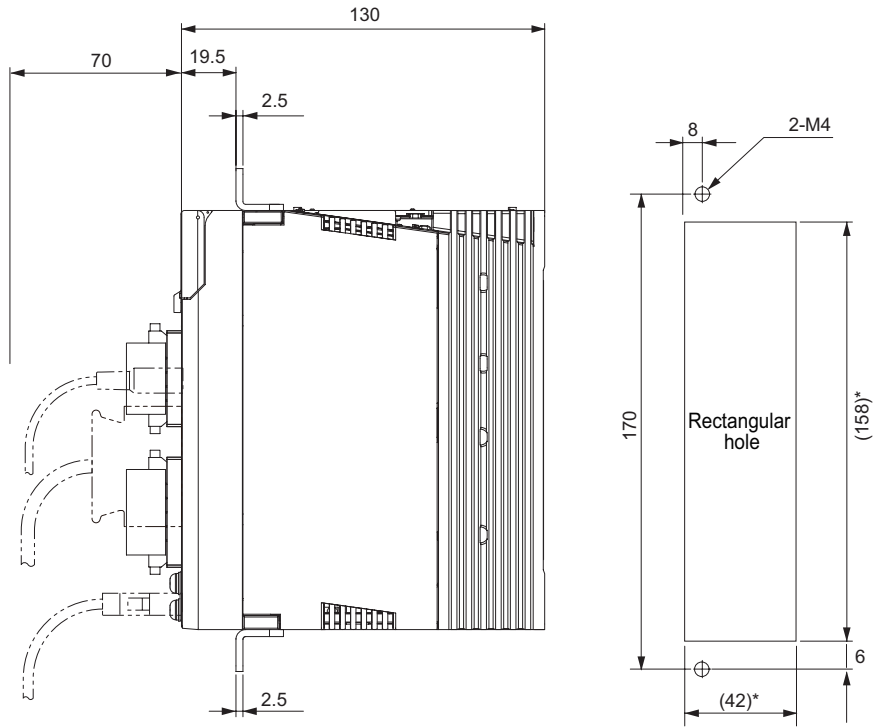

* Rectangular hole dimensions are reference values.

Single-phase/3-phase 200 VAC: R88D-KP04H (400 W)

● Wall Mounting

External Dimensions

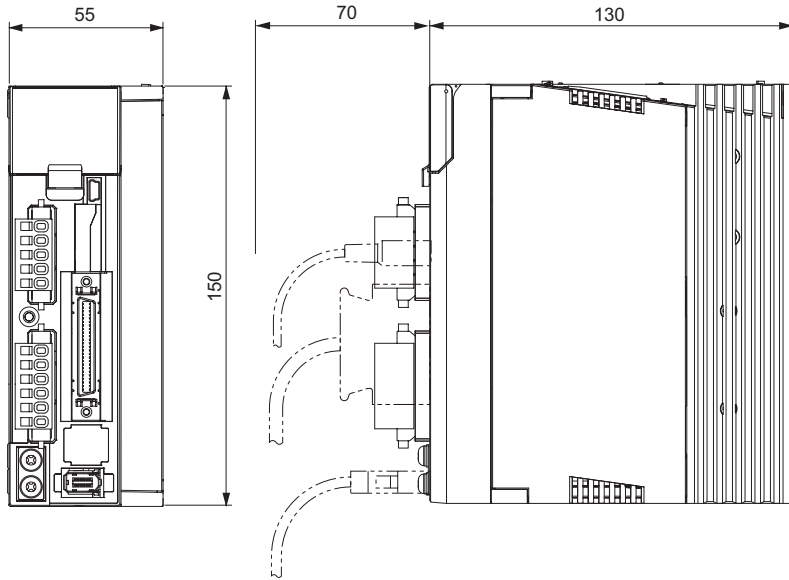

Mounting dimensions

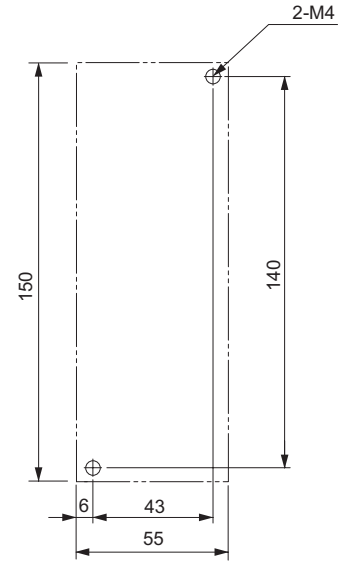

● Front Mounting (Using Front Mounting Brackets)

External Dimensions

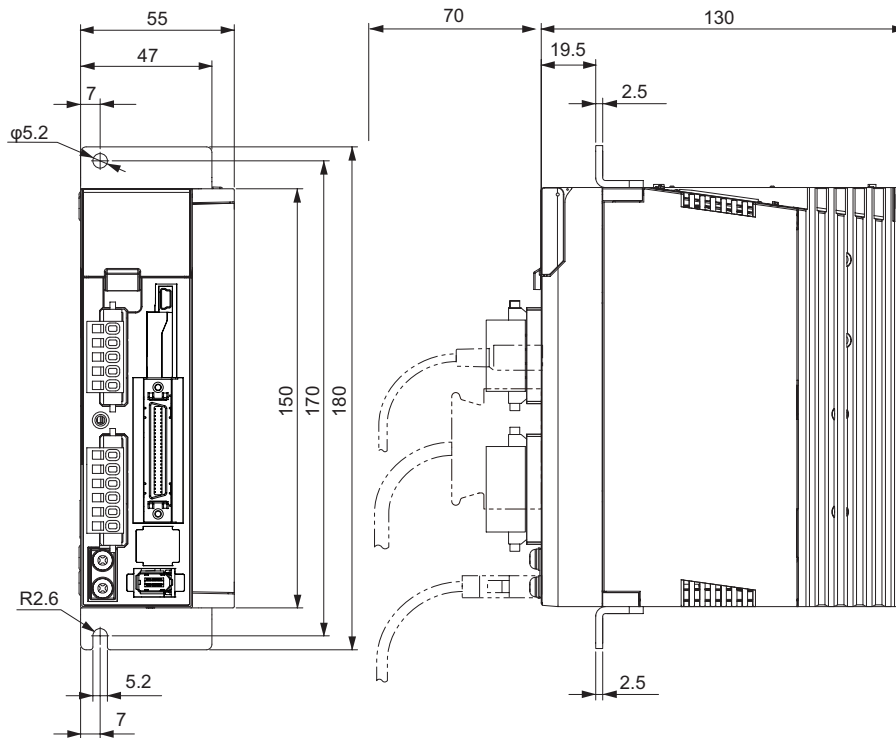

Mounting dimensions

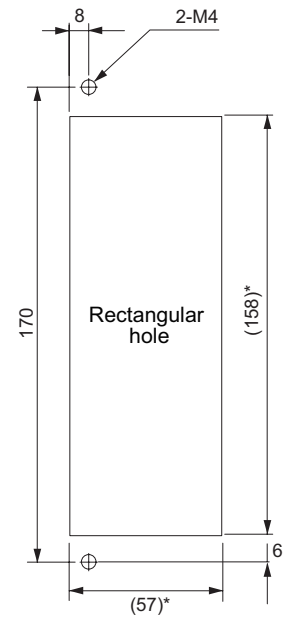

* Rectangular hole dimensions are reference values.

Single-phase/3-phase 200 VAC: R88D-KP08H (750 W)

● Wall Mounting

External Dimensions

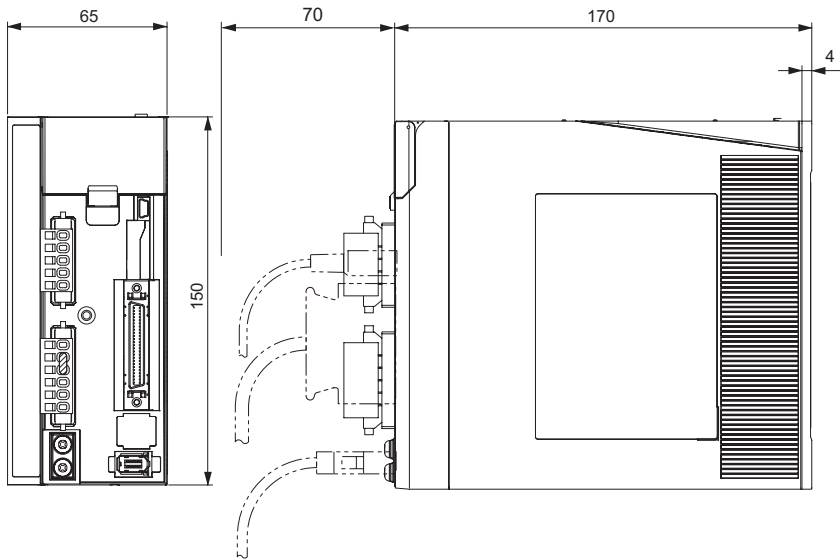

Mounting dimensions

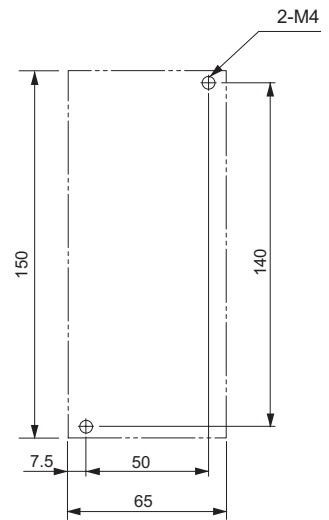

● Front Mounting (Using Front Mounting Brackets)

External Dimensions

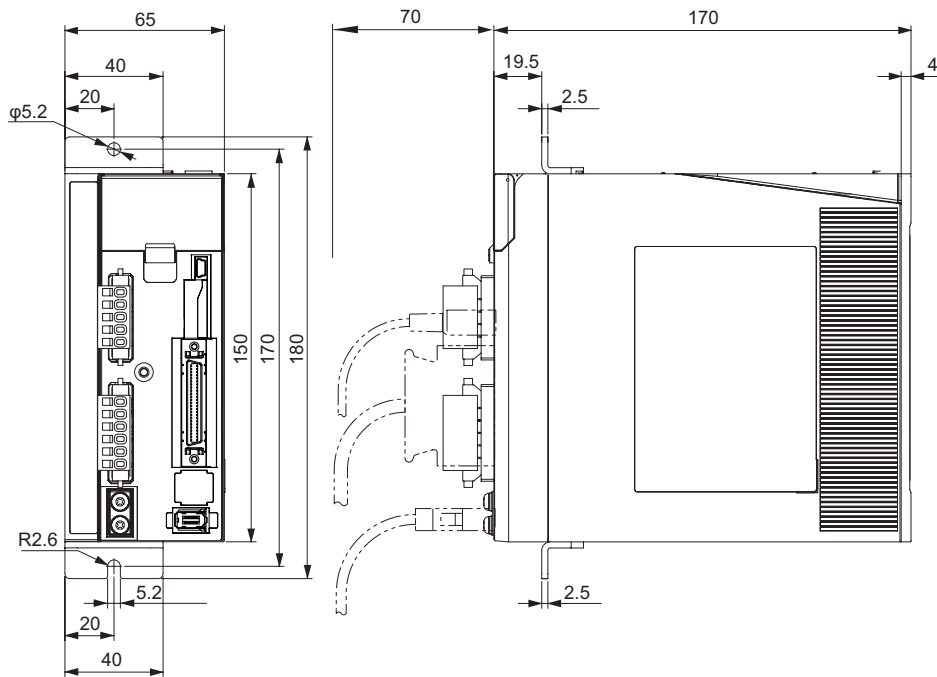

Mounting dimensions

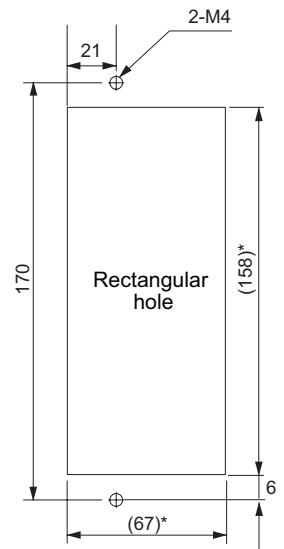

* Rectangular hole dimensions are reference values.

Single-phase/3-phase 200 VAC: R88D-KP10H/-KP15H (900 W to 1.5 kW)

● **Wall Mounting**

External Dimensions

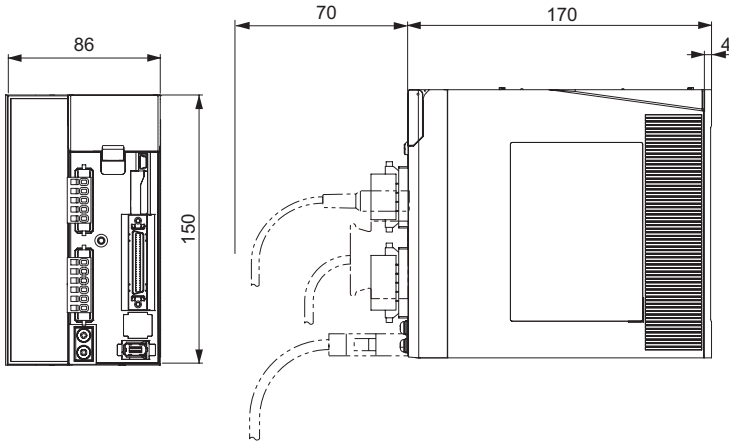

Mounting dimensions

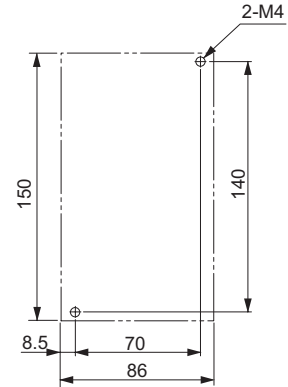

● **Front Mounting (Using Front Mounting Brackets)**

External Dimensions

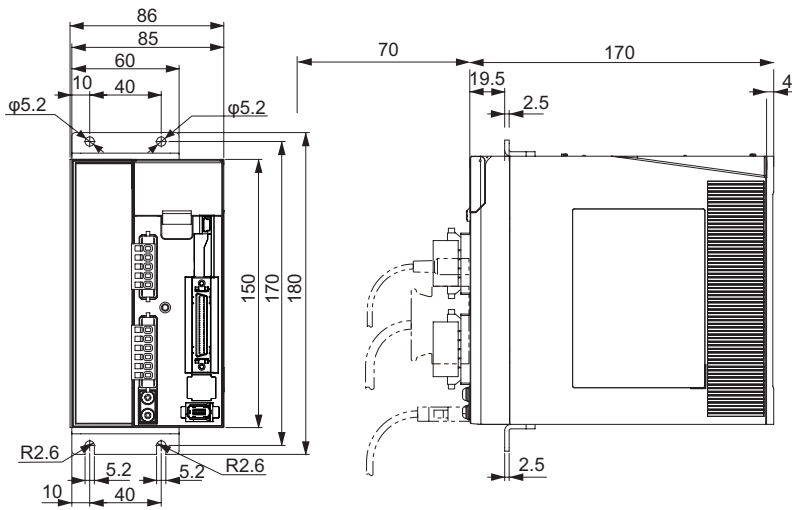

Mounting dimensions

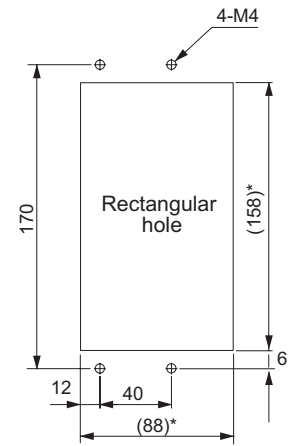

* Rectangular hole dimensions are reference values.

3-phase 200 VAC: R88D-KP20H (2 kW)

● Wall Mounting

External Dimensions

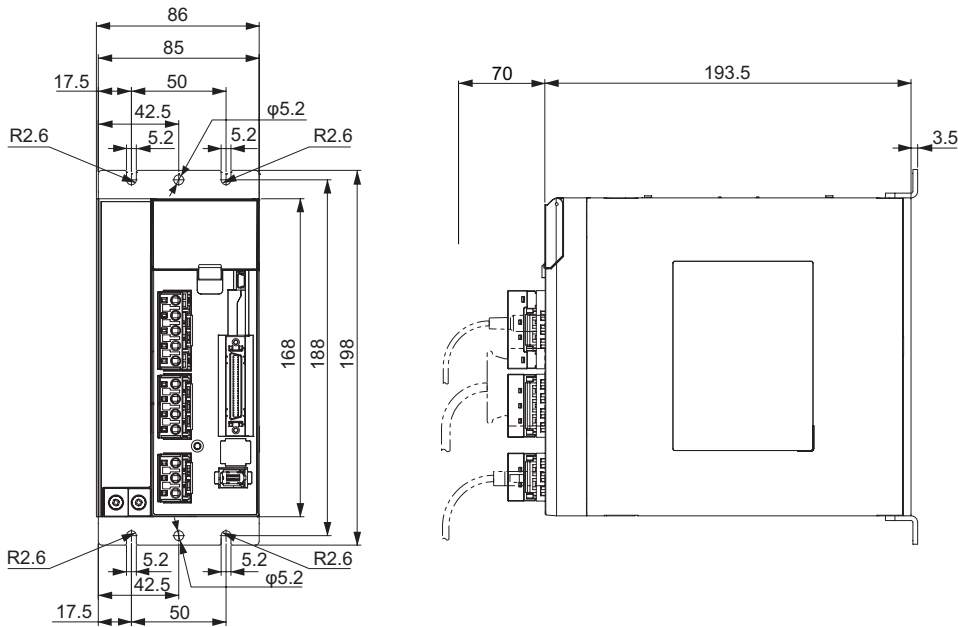

Mounting dimensions

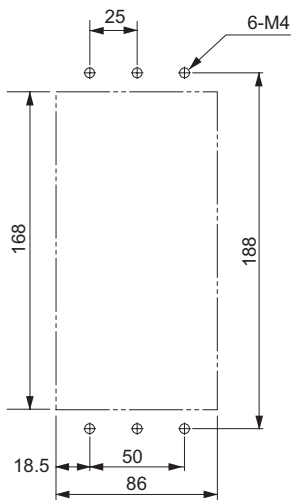

● **Front Mounting (Using Front Mounting Brackets)**

External Dimensions

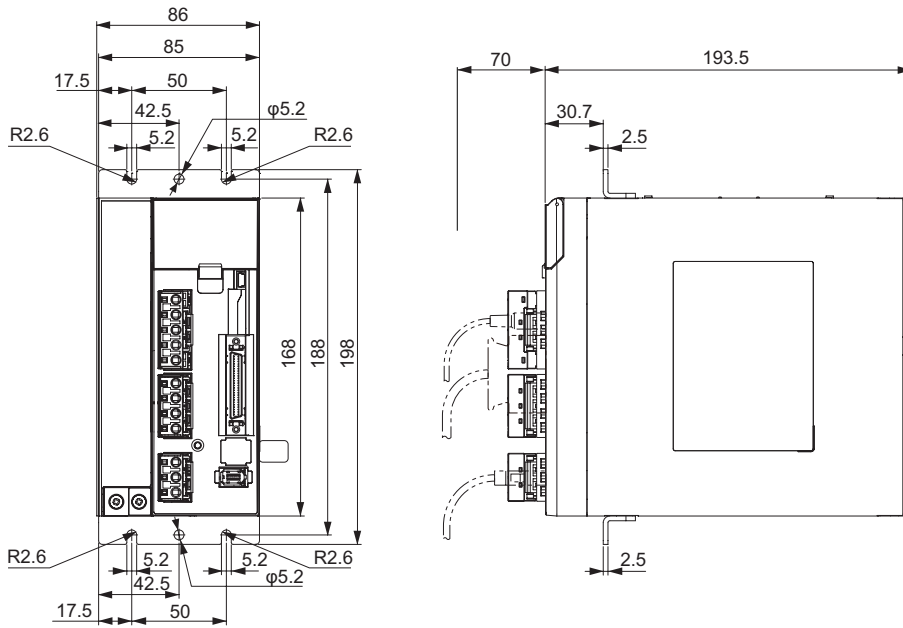

Mounting dimensions

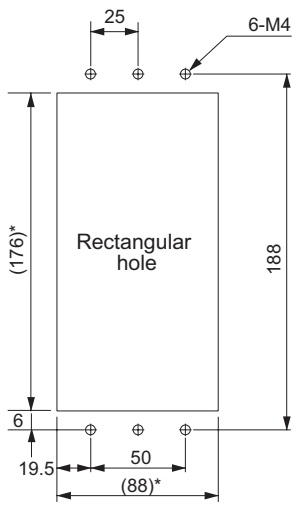

* Rectangular hole dimensions are reference values.

3-phase 200 VAC: R88D-KP30H/-KP50H (3 to 5 kW)

● Wall Mounting

External Dimensions

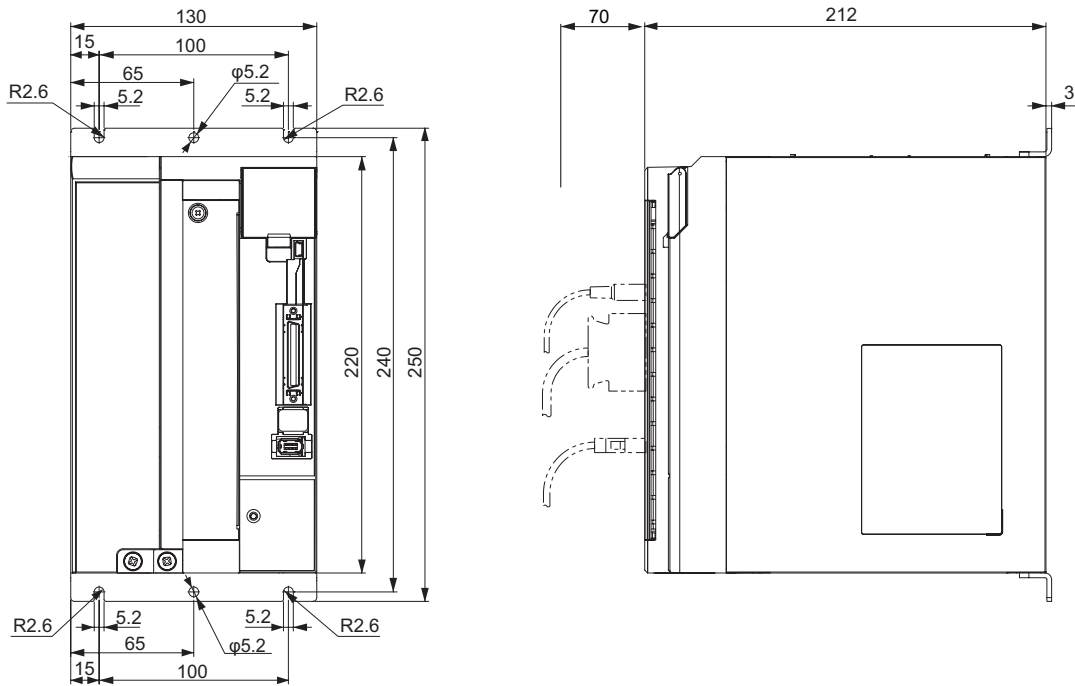

Mounting dimensions

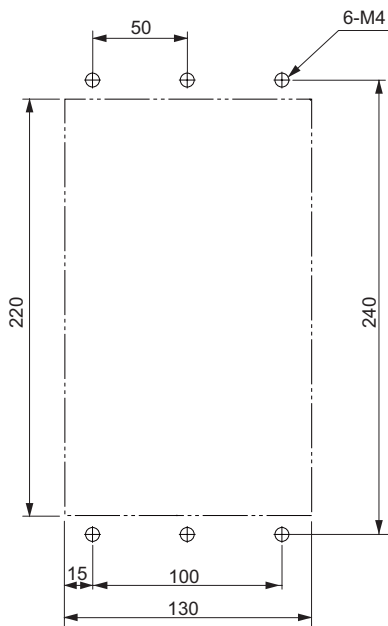

● **Front Mounting (Using Front Mounting Brackets)**

External Dimensions

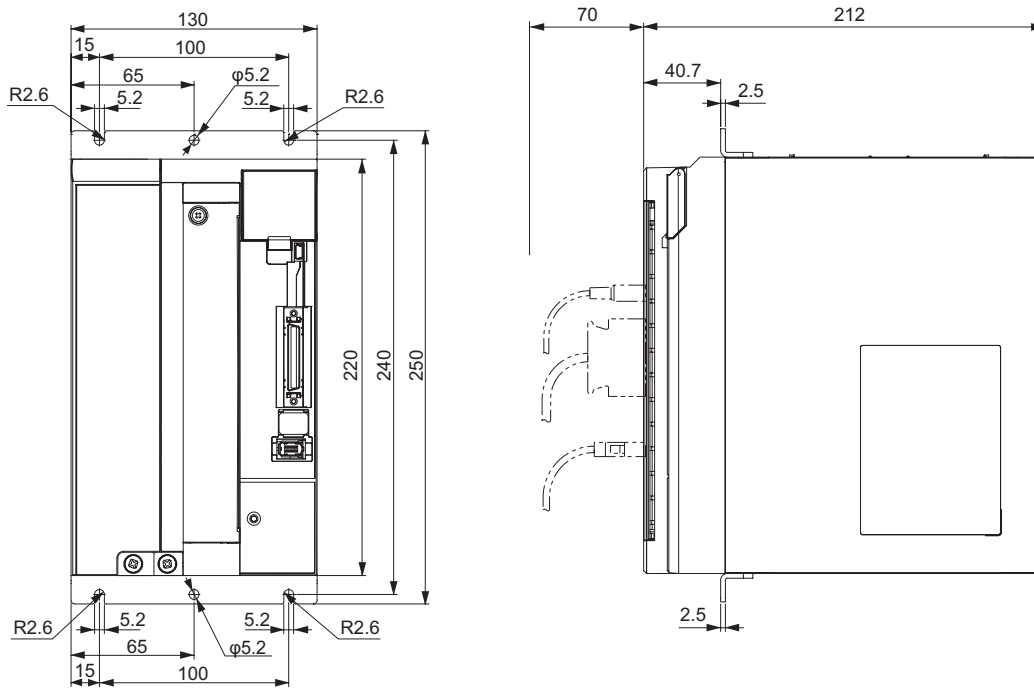

Mounting dimensions

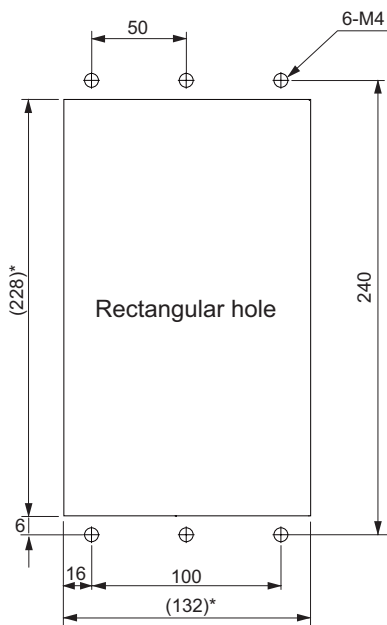

* Rectangular hole dimensions are reference values.

2-4-2 Servomotor Dimensions

3,000-r/min Servomotors (200 V)

● 50 W/100 W (without Brake)

R88M-KE05030H (-S2)/-KE10030H (-S2)

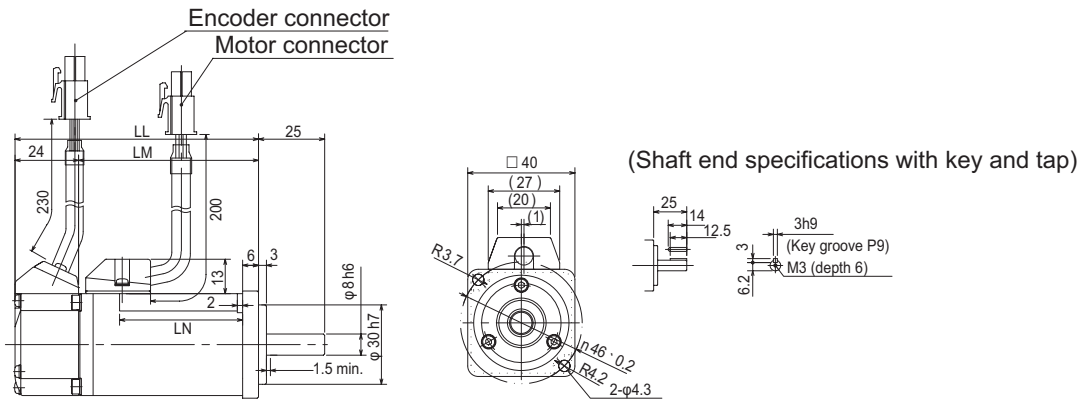

Model	Dimensions [mm]		
	LL	LM	LN
R88M-KE05030□	72	48	26.5
R88M-KE10030□	92	68	46.5

Note The standard models have a straight shaft. Models with a key and tap are indicated with S2 at the end of the model number.

Models with an oil seal are indicated with O at the end of the model number. The motor dimensions do not change.

● 50 W/100 W (with Brake)

R88M-KE05030H-B (S2)/-KE10030H-B (S2)

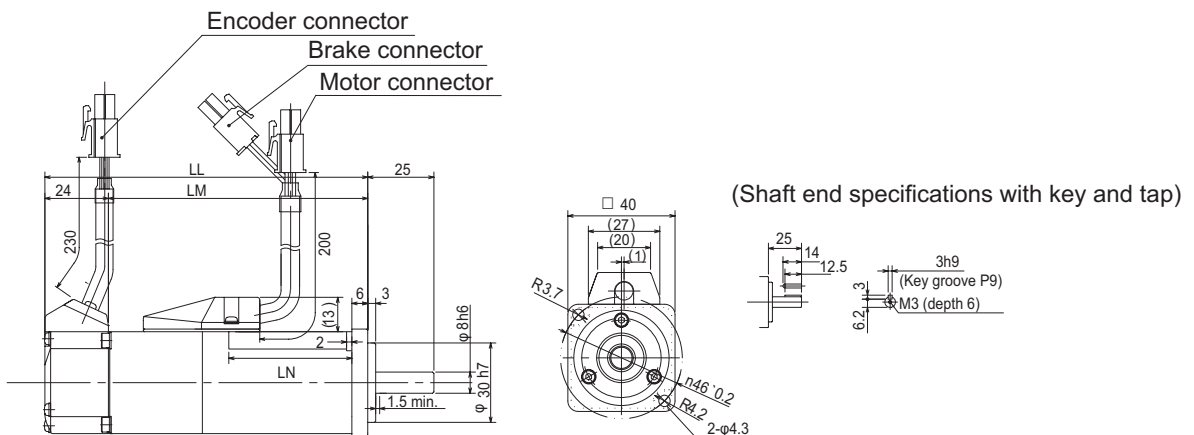

Model	Dimensions [mm]		
	LL	LM	LN
R88M-KE05030□-B□	102	78	26.5
R88M-KE10030□-B□	122	98	46.5

Note The standard models have a straight shaft. Models with a key and tap are indicated with S2 at the end of the model number.

Models with an oil seal are indicated with O at the end of the model number. The motor dimensions do not change.

● 200 W/400 W (without Brake)

R88M-KE20030□ (-S2)/-KE40030□ (-S2)

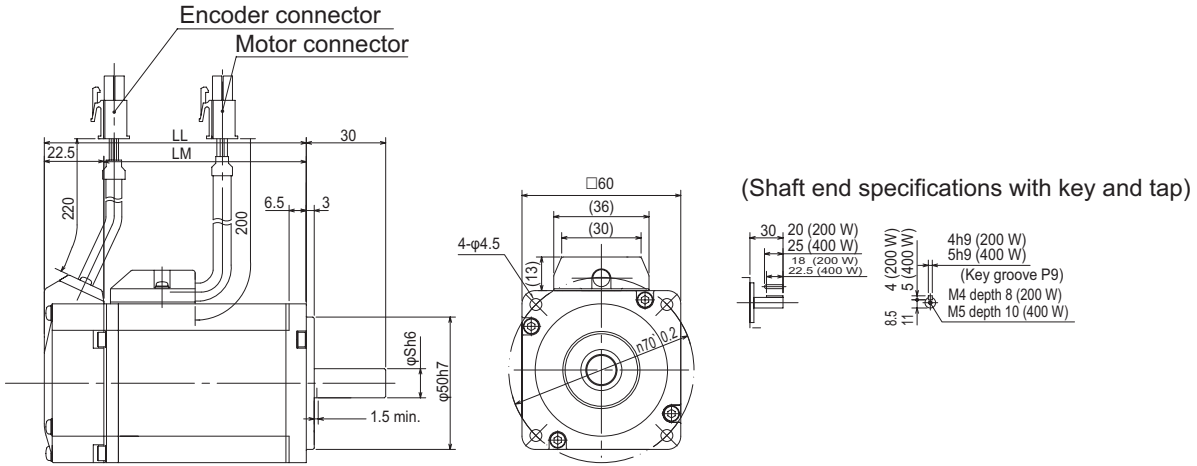

Model	Dimensions [mm]		
	LL	LM	S
R88M-KE20030□	79.5	57	11
R88M-KE40030□	99	76.5	14

Note The standard models have a straight shaft. Models with a key and tap are indicated with S2 at the end of the model number.

Models with an oil seal are indicated with O at the end of the model number. The motor dimensions do not change.

● 200 W/400 W (with Brake)

R88M-KE20030□-B (S2)/-KE40030□-B (S2)

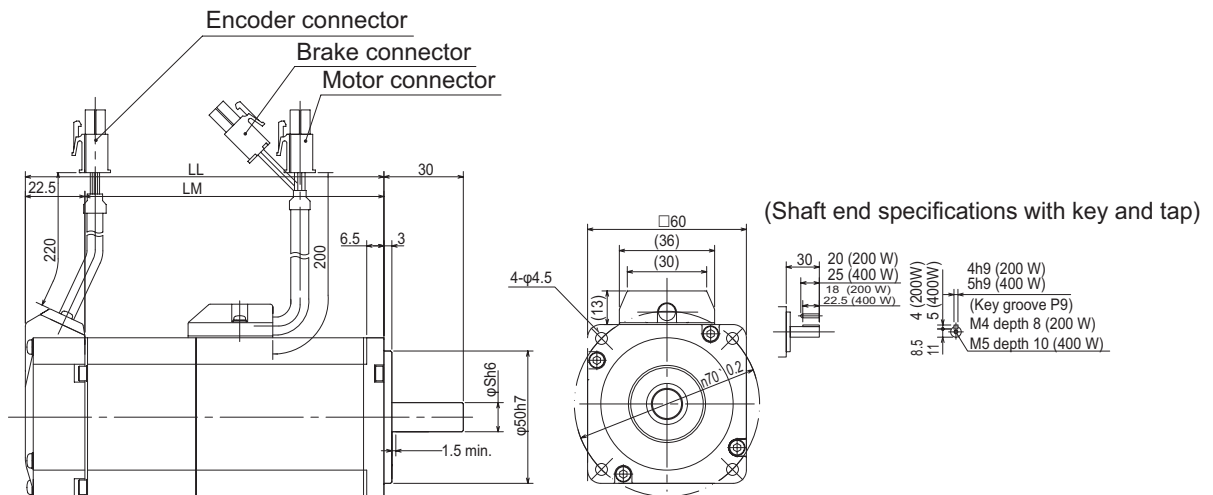

Model	Dimensions [mm]		
	LL	LM	S
R88M-KE20030□-B□	116	93.5	11
R88M-KE40030□-B□	135.5	113	14

Note The standard models have a straight shaft. Models with a key and tap are indicated with S2 at the end of the model number.

Models with an oil seal are indicated with O at the end of the model number. The motor dimensions do not change.

● 750 W (without Brake)

R88M-KE75030H (-S2)

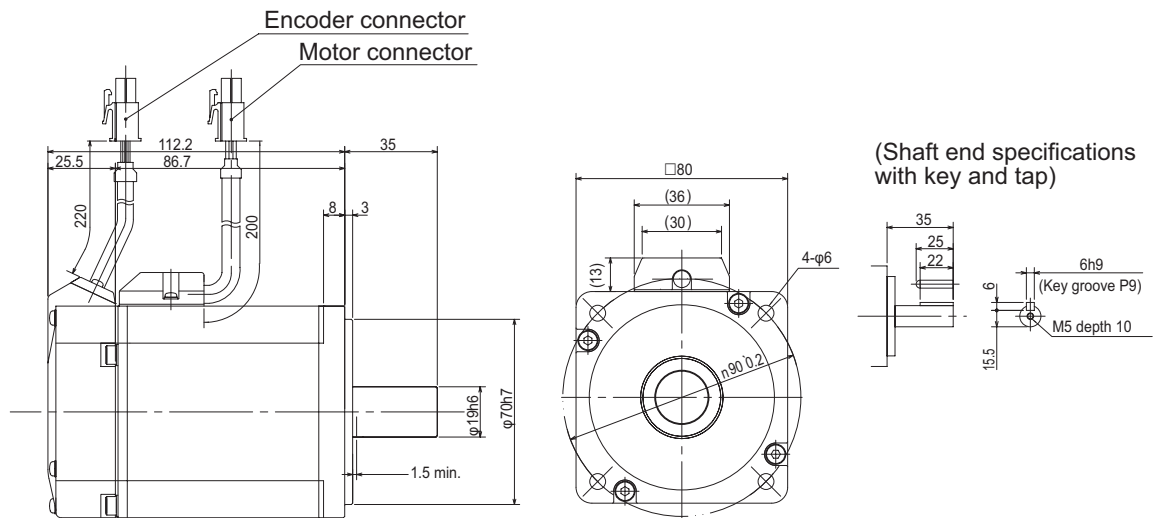

Note The standard models have a straight shaft. Models with a key and tap are indicated with S2 at the end of the model number.

Models with an oil seal are indicated with O at the end of the model number. The motor dimensions do not change.

● 750 W (with Brake)

R88M-KE75030H-B (S2)

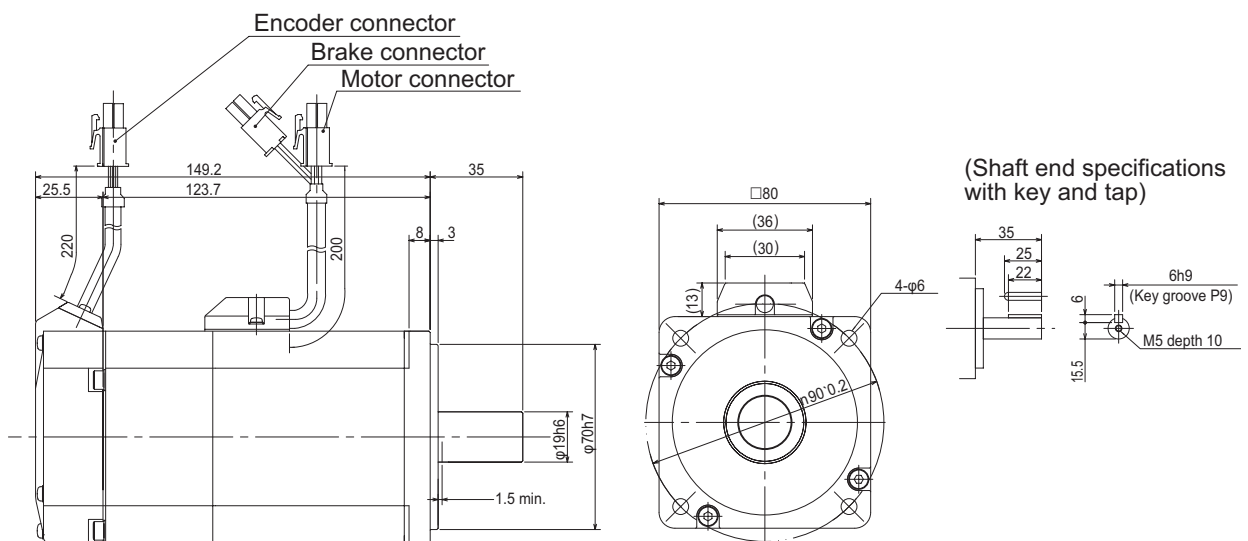

Note The standard models have a straight shaft. Models with a key and tap are indicated with S2 at the end of the model number.

Models with an oil seal are indicated with O at the end of the model number. The motor dimensions do not change.

● **1 kW/1.5 kW/2 kW (without Brake)**

R88M-KE1K030H (-S2)/-KE1K530H (-S2)/-KE2K030H (-S2)

● **1 kW/1.5 kW/2 kW (with Brake)**

R88M-KE1K030H-B (S2)/-KE1K530H-B (S2)/-KE2K030H-B (S2)

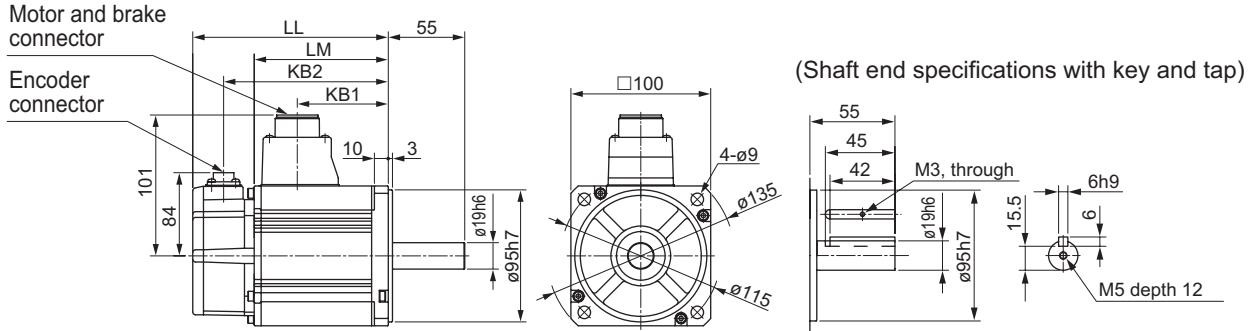

Model	Dimensions [mm]			
	LL	LM	KB1	KB2
R88M-KE1K030□	142	97	66	122
R88M-KE1K530□	160.5	115.5	84.5	140.5
R88M-KE2K030□	179.5	134.5	103.5	159.5
R88M-KE1K030□-B□	169	124	66	149
R88M-KE1K530□-B□	187.5	142.5	84.5	167.5
R88M-KE2K030□-B□	206.5	161.5	103.5	186.5

Note The standard models have a straight shaft. Models with a key and tap are indicated with S2 at the end of the model number.
Models with an oil seal are indicated with O at the end of the model number. The motor dimensions do not change.

● **3 kW (without Brake)**

R88M-KE3K030H (-S2)

● **3 kW (with Brake)**

R88M-KE3K030H-B (S2)

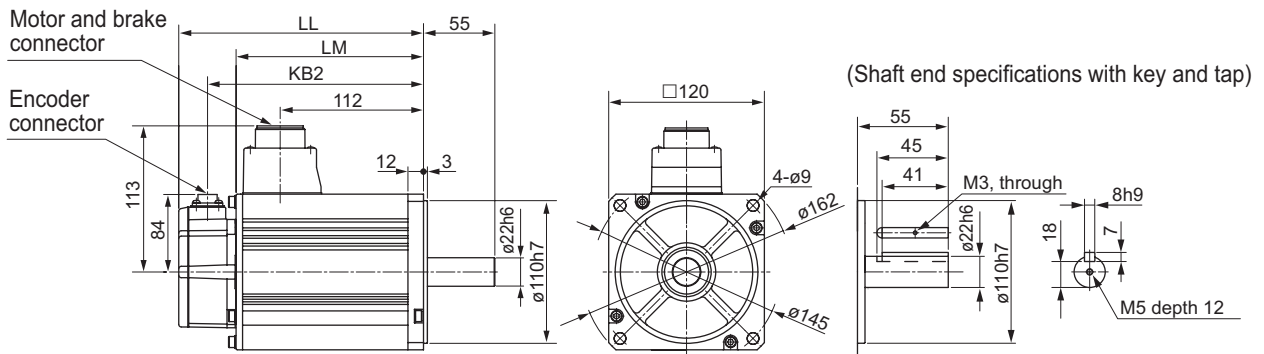

Model	Dimensions [mm]		
	LL	LM	KB2
R88M-KE3K030□	191	146	171
R88M-KE3K030□-B□	216	171	196

Note The standard models have a straight shaft. Models with a key and tap are indicated with S2 at the end of the model number.
Models with an oil seal are indicated with O at the end of the model number. The motor dimensions do not change.

● 4 kW/5 kW (without Brake)

R88M-KE4K030H (-S2)/-KE5K030H (-S2)

● 4 kW/5 kW (with Brake)

R88M-KE4K030H-B (S2)/-KE5K030H-B (S2)

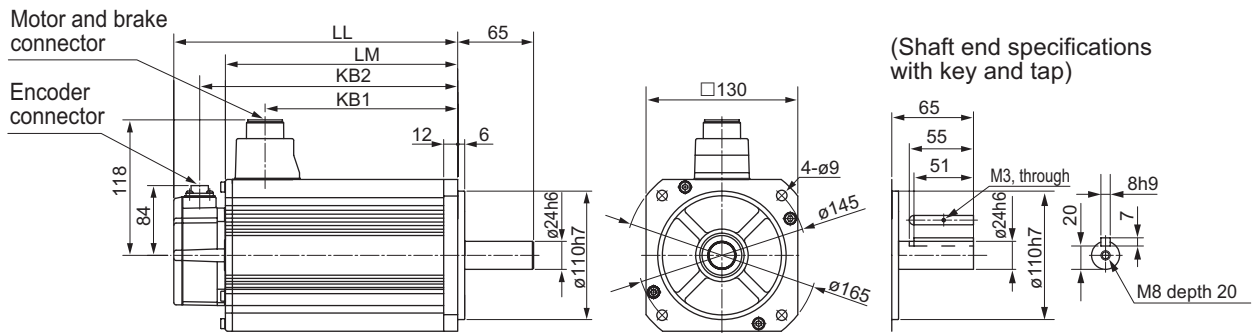

Model	Dimensions [mm]			
	LL	LM	KB1	KB2
R88M-KE4K030□	209	164	127	189
R88M-KE5K030□	244	199	162	224
R88M-KE4K030□-B□	237	192	127	217
R88M-KE5K030□-B□	272	227	162	252

Note The standard models have a straight shaft. Models with a key and tap are indicated with S2 at the end of the model number.
 Models with an oil seal are indicated with O at the end of the model number. The motor dimensions do not change.

2,000-r/min Servomotors (200 V)

- 1 kW/1.5 kW/2 kW/3 kW (without Brake)

R88M-KE1K020H (-S2)/-KE1K520H (-S2)/-KE2K020H (-S2)/-KE3K020H (-S2)

- 1 kW/1.5 kW/2 kW/3 kW (with Brake)

R88M-KE1K020H-B (S2)/-KE1K520H-B (S2)/-KE2K020H-B (S2)/-KE3K020H-B (S2)

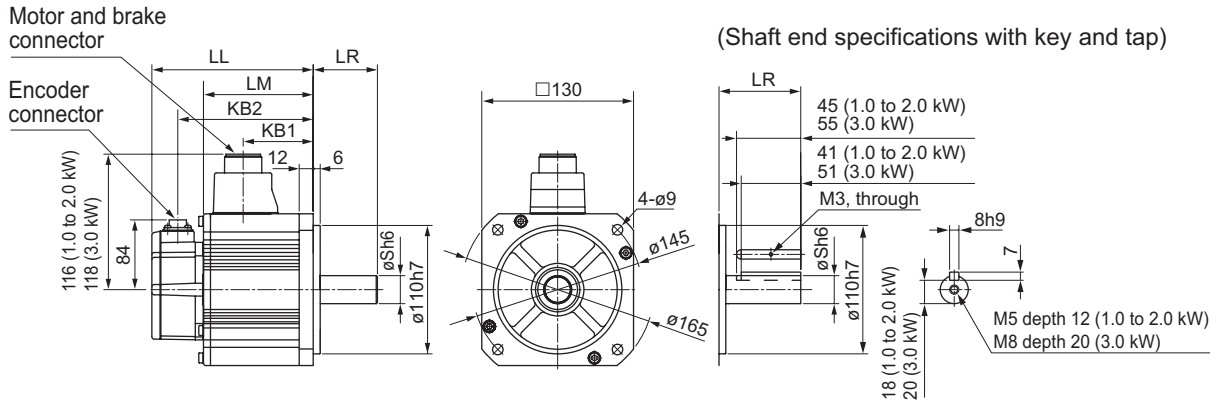

Model	Dimensions [mm]					
	LL	LR	LM	S	KB1	KB2
R88M-KE1K020□	139	55	94	22	60	119
R88M-KE1K520□	156.5	55	111.5	22	77.5	136.5
R88M-KE2K020□	174	55	129	22	95	154
R88M-KE3K020□	209	65	164	24	127	189
R88M-KE1K020□-B□	167	55	122	22	60	147
R88M-KE1K520□-B□	184.5	55	139.5	22	77.5	164.5
R88M-KE2K020□-B□	202	55	157	22	95	182
R88M-KE3K020□-B□	237	65	192	24	127	217

Note The standard models have a straight shaft. Models with a key and tap are indicated with S2 at the end of the model number.
 Models with an oil seal are indicated with O at the end of the model number. The motor dimensions do not change.

● 4 kW/5 kW (without Brake)

R88M-KE4K020H (-S2)/-KE5K020H (-S2)

● 4 kW/5 kW (with Brake)

R88M-KE4K020H-B (S2)/-KE5K020H-B (S2)

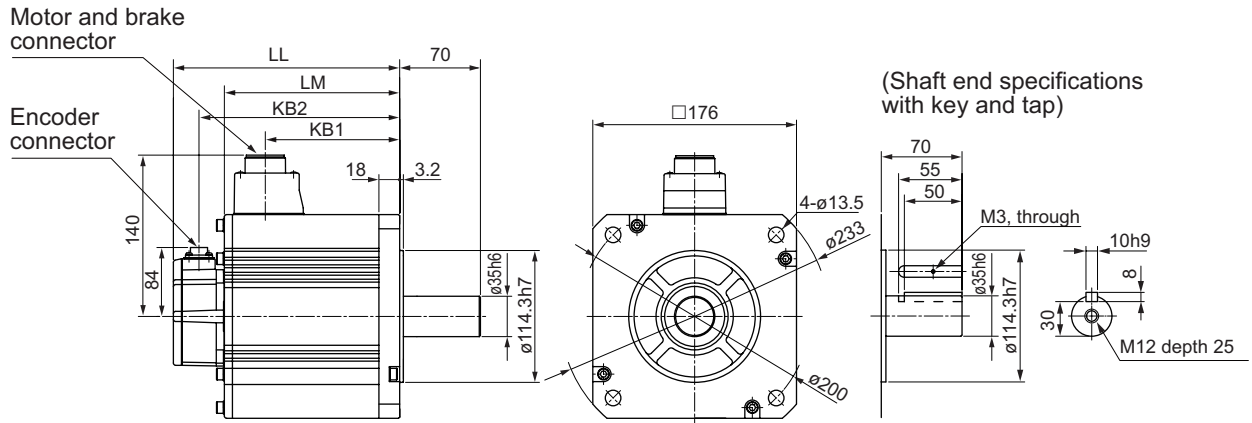

Model	Dimensions [mm]			
	LL	LM	KB1	KB2
R88M-KE4K020□	178	133	96	158
R88M-KE5K020□	197	152	115	177
R88M-KE4K020□-B□	207	162	96	187
R88M-KE5K020□-B□	226	181	115	206

Note The standard models have a straight shaft. Models with a key and tap are indicated with S2 at the end of the model number.
 Models with an oil seal are indicated with O at the end of the model number. The motor dimensions do not change.

1,000-r/min Servomotors (200 V)

- **900 W (without Brake)**

R88M-KE90010H (-S2)

- **900 W (with Brake)**

R88M-KE90010H-B (S2)

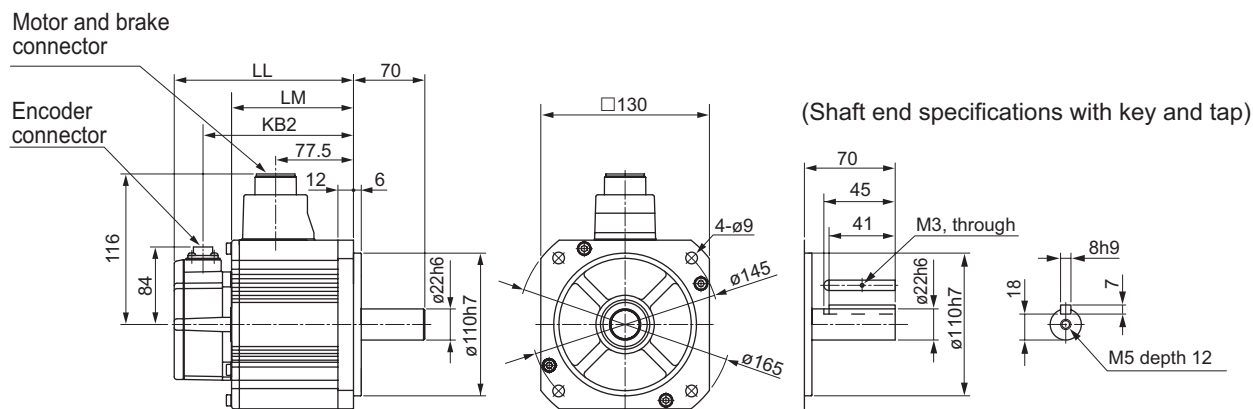

Model	Dimensions [mm]		
	LL	LM	KB2
R88M-KE90010□	156.5	111.5	136.5
R88M-KE90010□-B□	184.5	139.5	164.5

Note The standard models have a straight shaft. Models with a key and tap are indicated with S2 at the end of the model number.
Models with an oil seal are indicated with O at the end of the model number. The motor dimensions do not change.

● **2 kW/3 kW (without Brake)**

R88M-KE2K010H (-S2)/-KE3K010H (-S2)

● **2 kW/3 kW (with Brake)**

R88M-KE2K010H-B (S2)/-KE3K010H-B (S2)

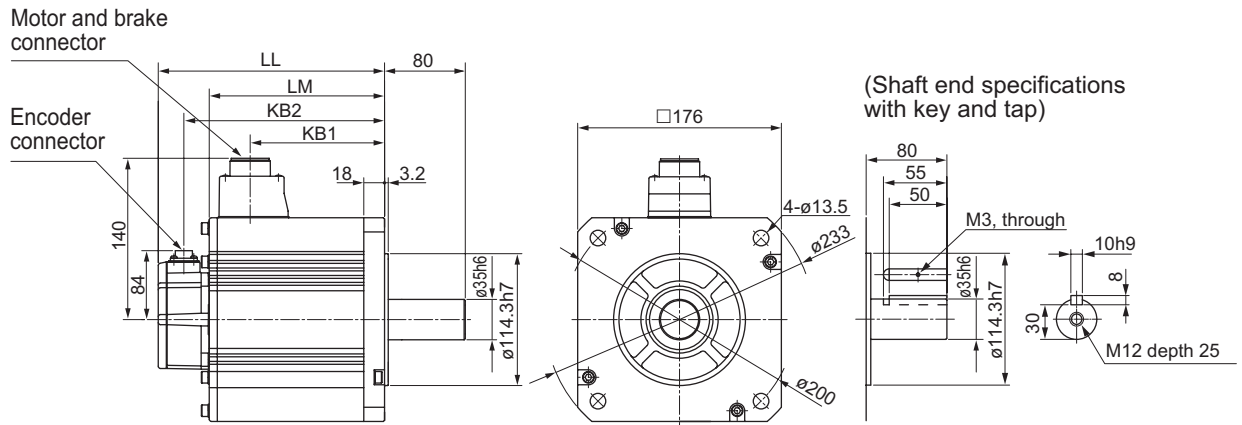

Model	Dimensions [mm]			
	LL	LM	KB1	KB2
R88M-KE2K010□	164.5	119.5	82.5	144.5
R88M-KE3K010□	210.5	165.5	128.5	190.5
R88M-KE2K010□-B□	193.5	148.5	82.5	173.5
R88M-KE3K010□-B□	239.5	194.5	128.5	219.5

Note The standard models have a straight shaft. Models with a key and tap are indicated with S2 at the end of the model number.
 Models with an oil seal are indicated with O at the end of the model number. The motor dimensions do not change.

2-4-3 Combinations of Servomotors and Decelerators

● 3,000-r/min Servomotors

Servomotor models	1/5	1/11 (1/9 for flange 11)	1/21	1/33	1/45
R88M-KE05030□	R88G-HPG11B05100B□ (for both with R88M-KE10030□)	R88G-HPG11B09050B□ (Gear ratio 1/9)	R88G-HPG14A21100B□ (for both with R88M-KE10030□)	R88G-HPG14A33050B□	R88G-HPG14A45050B□
R88M-KE10030□	R88G-HPG11B05100B□	R88G-HPG14A11100B□	R88G-HPG14A21100B□	R88G-HPG20A33100B□	R88G-HPG20A45100B□
R88M-KE20030□	R88G-HPG14A05200B□	R88G-HPG14A11200B□	R88G-HPG20A21200B□	R88G-HPG20A33200B□	R88G-HPG20A45200B□
R88M-KE40030□	R88G-HPG14A05400B□	R88G-HPG20A11400B□	R88G-HPG20A21400B□	R88G-HPG32A33400B□	R88G-HPG32A45400B□
R88M-KE75030H/T	R88G-HPG20A05750B□	R88G-HPG20A11750B□	R88G-HPG32A21750B□	R88G-HPG32A33750B□	R88G-HPG32A45750B□
R88M-KE1K030□	R88G-HPG32A052K0B□ (for both with R88M-KE2K030□)	R88G-HPG32A112K0B□ (for both with R88M-KE2K030□)	R88G-HPG32A211K5B□ (for both with R88M-KE1K5030□)	R88G-HPG50A332K0B□ (for both with R88M-KE2K030□)	R88G-HPG50A451K5B□ (for both with R88M-KE1K530□)
R88M-KE1K530□	R88G-HPG32A052K0B□ (for both with R88M-KE2K030□)	R88G-HPG32A112K0B□ (for both with R88M-KE2K030□)	R88G-HPG32A211K5B□	R88G-HPG50A332K0B□ (for both with R88M-KE2K030□)	R88G-HPG50A451K5B□
R88M-KE2K030□	R88G-HPG32A052K0B□	R88G-HPG32A112K0B□	R88G-HPG50A212K0B□	R88G-HPG50A332K0B□	–
R88M-KE3K030□	R88G-HPG32A053K0B□	R88G-HPG50A113K0B□	R88G-HPG50A213K0B□	–	–
R88M-KE4K030□	R88G-HPG32A054K0B□	R88G-HPG50A115K0B□ (for both with R88M-KE5K030□)	–	–	–
R88M-KE5K030□	R88G-HPG50A055K0B□	R88G-HPG50A115K0B□	–	–	–

● 2,000-r/min Servomotors

Servomotor models	1/5	1/11	1/21 (1/20 for flange 65)	1/33 (1/25 for flange 65)	1/45
R88M-KE1K020□	R88G-HPG32A053K0B□ (for both with R88M-KE3K030□)	R88G-HPG32A112K0SB□ (for both with R88M-KE2K020□)	R88G-HPG32A211K0SB□	R88G-HPG50A332K0SB□ (for both with R88M-KE2K020□)	R88G-HPG50A451K0SB□
R88M-KE1K520□	R88G-HPG32A053K0B□ (for both with R88M-KE3K030□)	R88G-HPG32A112K0SB□ (for both with R88M-KE2K020□)	R88G-HPG50A213K0B□ (for both with R88M-KE3K030□)	R88G-HPG50A332K0SB□ (for both with R88M-KE2K020□)	—
R88M-KE2K020□	R88G-HPG32A053K0B□ (for both with R88M-KE3K030□)	R88G-HPG32A112K0SB□	R88G-HPG50A213K0B□ (for both with R88M-KE3K030□)	R88G-HPG50A332K0SB□	—
R88M-KE3K020□	R88G-HPG32A054K0B□ (for both with R88M-KE4K030□)	R88G-HPG50A115K0B□ (for both with R88M-KE5K030□)	R88G-HPG50A213K0SB□	R88G-HPG65A253K0SB□	—
R88M-KE4K020□	R88G-HPG50A055K0SB□ (for both with R88M-KE5K020□)	R88G-HPG50A115K0SB□ (for both with R88M-KE3K030□)	R88G-HPG65A205K0SB□ (for both with R88M-KE3K030□)	R88G-HPG65A255K0SB□ (for both with R88M-KE5K020□)	—
R88M-KE5K020□	R88G-HPG50A055K0SB□	R88G-HPG50A115K0SB□	R88G-HPG65A205K0SB□	R88G-HPG65A255K0SB□	—

● 1,000-r/min Servomotors

Servomotor models	1/5	1/11	1/21 (1/20 for flange 65)	1/33 (1/25 for flange 65)
R88M-KE90010□	R88G-HPG32A05900TB□	R88G-HPG32A11900TB□	R88G-HPG50A21900TB□	R88G-HPG50A33900TB□
R88M-KE2K010□	R88G-HPG32A052K0TB□	R88G-HPG50A112K0TB□	R88G-HPG50A212K0TB□ (for both with R88M-KE5K020□)	R88G-HPG65A255K0SB□ (for both with R88M-KE5K020□)
R88M-KE3K010□	R88G-HPG50A055K0SB□ (for both with R88M-KE5K020□)	R88G-HPG50A115K0SB□ (for both with R88M-KE5K020□)	R88G-HPG65A205K0SB (for both with R88M-KE5K020□)	R88G-HPG65A255K0SB□ (for both with R88M-KE5K020□)

2-4-4 Decelerator Dimensions

Backlash: 3 Arcminutes max.

● For 3,000-r/min Servomotors (50 to 200 W)

Model			Outline drawing	Dimensions [mm]											
				LM	LR	C1	C2	D1	D2	D3	D4	D5	E	F1	F2
50 W	1/5	R88G-HPG11B05100B□	1	39.5	42	40	□40	46	46	40	39.5	29	27	2.2	15
	1/9	R88G-HPG11B09050B□	1	39.5	42	40	□40	46	46	40	39.5	29	27	2.2	15
	1/21	R88G-HPG14A21100B□	1	64.0	58	60	□60	70	46	56	55.5	40	37	2.5	21
	1/33	R88G-HPG14A33050B□	1	64.0	58	60	□60	70	46	56	55.5	40	37	2.5	21
	1/45	R88G-HPG14A45050B□	1	64.0	58	60	□60	70	46	56	55.5	40	37	2.5	21
100 W	1/5	R88G-HPG11B05100B□	1	39.5	42	40	□40	46	46	40	39.5	29	27	2.2	15
	1/11	R88G-HPG14A11100B□	1	64.0	58	60	□60	70	46	56	55.5	40	37	2.5	21
	1/21	R88G-HPG14A21100B□	1	64.0	58	60	□60	70	46	56	55.5	40	37	2.5	21
	1/33	R88G-HPG20A33100B□	2	66.5	80	90	ø55	105	46	85	84	59	53	7.5	27
	1/45	R88G-HPG20A45100B□	2	66.5	80	90	ø55	105	46	85	84	59	53	7.5	27
200 W	1/5	R88G-HPG14A05200B□	1	64.0	58	60	□60	70	70	56	55.5	40	37	2.5	21
	1/11	R88G-HPG14A11200B□	1	64.0	58	60	□60	70	70	56	55.5	40	37	2.5	21
	1/21	R88G-HPG20A21200B□	2	71.0	80	90	ø89	105	70	85	84	59	53	7.5	27
	1/33	R88G-HPG20A33200B□	2	71.0	80	90	ø89	105	70	85	84	59	53	7.5	27
	1/45	R88G-HPG20A45200B□	2	71.0	80	90	ø89	105	70	85	84	59	53	7.5	27

- Note 1** The standard shaft type is a straight shaft.
2 A model with a key and tap is indicated with J at the end of the model number (the suffix shown in the box). (Example: R88G-HPG11A05100BJ)
3 The diameter of the motor shaft insertion hole is the same as the shaft diameter of the corresponding Servomotor.
4 For Servomotors with a key, remove the key before use.

● Outline drawing 1

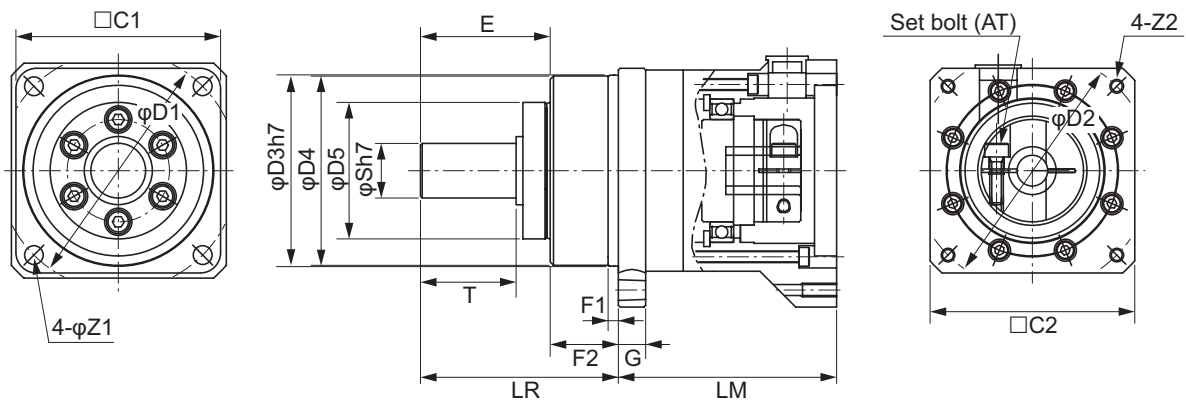

Key tap dimensions

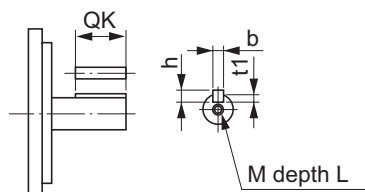

Dimensions [mm]													Model		
G	S	T	Z1	Z2	AT ^{*1}	Key				Tap					
						QK	b	h	t1	M	L				
5	8	20	3.4	M4 x 9	M3	15	3	3	1.8	M3	6	R88G-HPG11B05100B□	1/5	50 W	
5	8	20	3.4	M4 x 9	M3	15	3	3	1.8	M3	6	R88G-HPG11B09050B□	1/9		
8	16	28	5.5	M4 x 10	M3	25	5	5	3	M4	8	R88G-HPG14A21100B□	1/21		
8	16	28	5.5	M4 x 10	M3	25	5	5	3	M4	8	R88G-HPG14A33050B□	1/33	100 W	
8	16	28	5.5	M4 x 10	M3	25	5	5	3	M4	8	R88G-HPG14A45050B□	1/45		
5	8	20	3.4	M4 x 9	M3	15	3	3	1.8	M3	6	R88G-HPG11B05100B□	1/5		
8	16	28	5.5	M4 x 10	M3	25	5	5	3	M4	8	R88G-HPG14A11100B□	1/11	200 W	
8	16	28	5.5	M4 x 10	M3	25	5	5	3	M4	8	R88G-HPG14A21100B□	1/21		
10	25	42	9	M4 x 10	M4	36	8	7	4	M6	12	R88G-HPG20A33100B□	1/33		
10	25	42	9	M4 x 10	M4	36	8	7	4	M6	12	R88G-HPG20A45100B□	1/45	200 W	
8	16	28	5.5	M4 x 10	M4	25	5	5	3	M4	8	R88G-HPG14A05200B□	1/5		
8	16	28	5.5	M4 x 10	M4	25	5	5	3	M4	8	R88G-HPG14A11200B□	1/11		
10	25	42	9	M4 x 10	M4	36	8	7	4	M6	12	R88G-HPG20A21200B□	1/21		
10	25	42	9	M4 x 10	M4	36	8	7	4	M6	12	R88G-HPG20A33200B□	1/33		
10	25	42	9	M4 x 10	M4	36	8	7	4	M6	12	R88G-HPG20A45200B□	1/45		

*1 Indicates set bolt.

● Outline drawing 2

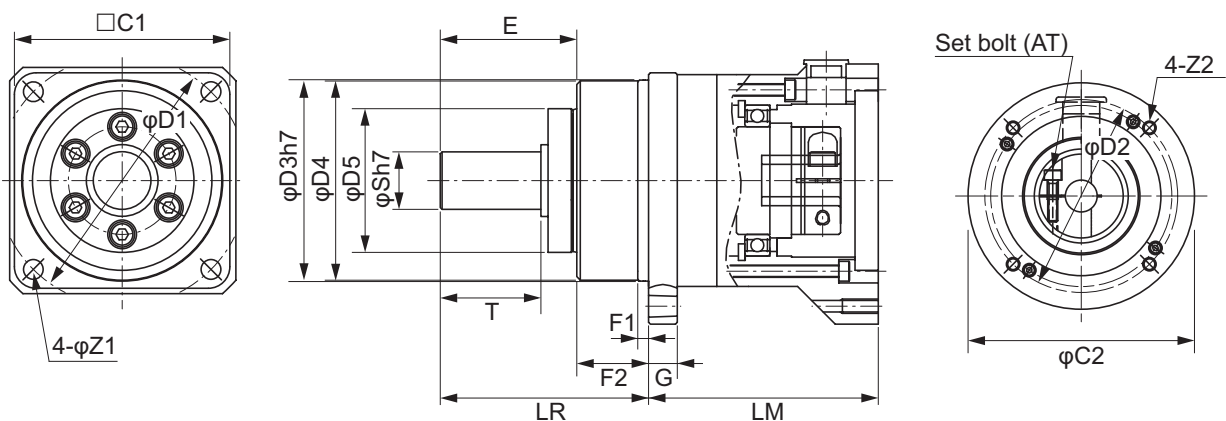

Key tap dimensions

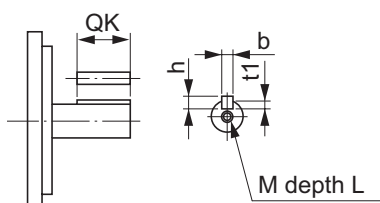

● For 3,000-r/min Servomotors (400 to 750 W)

Model			Outline drawing	Dimensions [mm]											
				LM	LR	C1	C2	D1	D2	D3	D4	D5	E	F1	F2
400 W	1/5	R88G-HPG14A05400B□	1	64	58	60	□60	70	70	56	55.5	40	37	2.5	21
	1/11	R88G-HPG20A11400B□	2	71	80	90	∅89	105	70	85	84	59	53	7.5	27
	1/21	R88G-HPG20A21400B□	2	71	80	90	∅89	105	70	85	84	59	53	7.5	27
	1/33	R88G-HPG32A33400B□	2	104	133	120	∅122	135	70	115	114	84	98	12.5	35
	1/45	R88G-HPG32A45400B□	2	104	133	120	∅122	135	70	115	114	84	98	12.5	35
750 W	1/5	R88G-HPG20A05750B□	1	78	80	90	□80	105	90	85	84	59	53	7.5	27
	1/11	R88G-HPG20A11750B□	1	78	80	90	□80	105	90	85	84	59	53	7.5	27
	1/21	R88G-HPG32A21750B□	2	104	133	120	∅122	135	90	115	114	84	98	12.5	35
	1/33	R88G-HPG32A33750B□	2	104	133	120	∅122	135	90	115	114	84	98	12.5	35
	1/45	R88G-HPG32A45750B□	2	104	133	120	∅122	135	90	115	114	84	98	12.5	35

Note 1 The standard shaft type is a straight shaft.

- 2 A model with a key and tap is indicated with J at the end of the model number (the suffix shown in the box). (Example: R88G-HPG14A05400BJ)
- 3 The diameter of the motor shaft insertion hole is the same as the shaft diameter of the corresponding Servomotor.
- 4 For Servomotors with a key, remove the key before use.

● Outline drawing 1

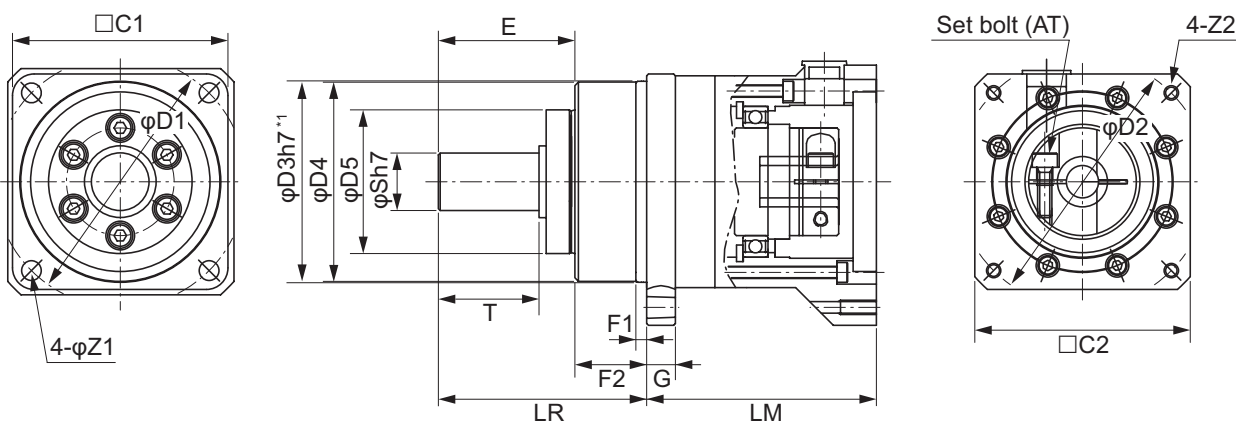

Key tap dimensions

*1 The tolerance is "h8" for R88G-HPG50□ or R88G-HPG65□.

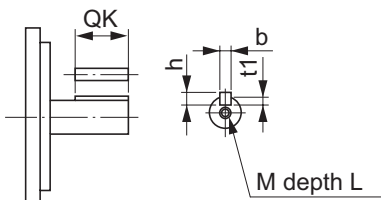

Dimensions [mm]												Model		
G	S	T	Z1	Z2	AT*1	Key				Tap				
						QK	b	h	t1	M	L			
8	16	28	5.5	M4 x 10	M4	25	5	5	3	M4	8	R88G-HPG14A05400B□	1/5	400 W
10	25	42	9	M4 x 10	M4	36	8	7	4	M6	12	R88G-HPG20A11400B□	1/11	
10	25	42	9	M4 x 10	M4	36	8	7	4	M6	12	R88G-HPG20A21400B□	1/21	
13	40	82	11	M4 x 10	M4	70	12	8	5	M10	20	R88G-HPG32A33400B□	1/33	
13	40	82	11	M4 x 10	M4	70	12	8	5	M10	20	R88G-HPG32A45400B□	1/45	
10	25	42	9	M5 x 12	M4	36	8	7	4	M6	12	R88G-HPG20A05750B□	1/5	750 W
10	25	42	9	M5 x 12	M4	36	8	7	4	M6	12	R88G-HPG20A11750B□	1/11	
13	40	82	11	M5 x 12	M6	70	12	8	5	M10	20	R88G-HPG32A21750B□	1/21	
13	40	82	11	M5 x 12	M6	70	12	8	5	M10	20	R88G-HPG32A33750B□	1/33	
13	40	82	11	M5 x 12	M6	70	12	8	5	M10	20	R88G-HPG32A45750B□	1/45	

*1 Indicates set bolt.

● Outline drawing 2

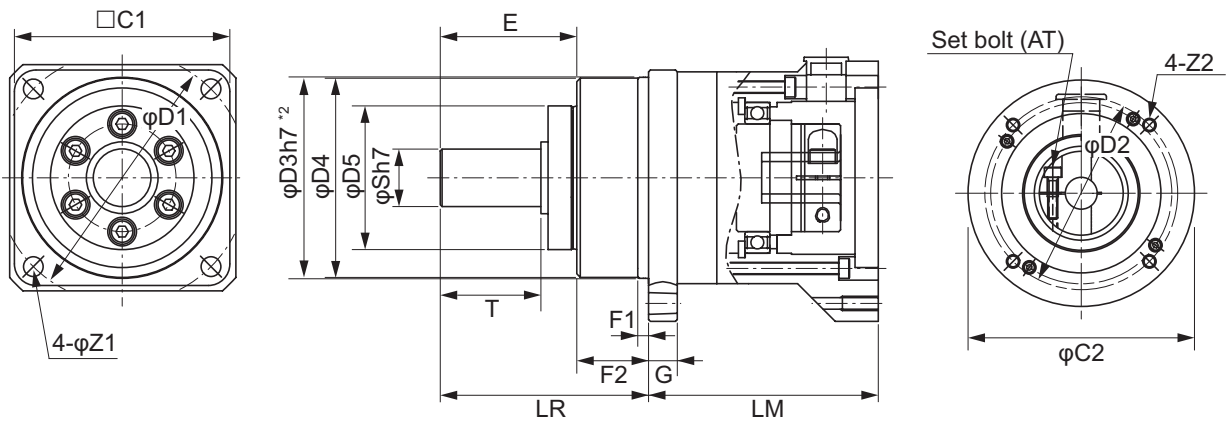

Key tap dimensions

*2 The tolerance is "h8" for R88G-HPG50□ or R88G-HPG65□.

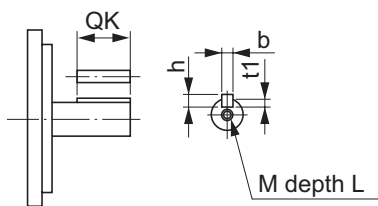

● For 3,000-r/min Servomotors (1 to 5 kW)

Model			Outline drawing	Dimensions [mm]											
				LM	LR	C1	C2	D1	D2	D3	D4	D5	E	F1	F2
1 kW	1/5	R88G-HPG32A052K0B□	2	110	133	120	∅135	135	115	115	114	84	98	12.5	35
	1/11	R88G-HPG32A112K0B□	2	110	133	120	∅135	135	115	115	114	84	98	12.5	35
	1/21	R88G-HPG32A211K5B□	2	110	133	120	∅135	135	115	115	114	84	98	12.5	35
	1/33	R88G-HPG50A332K0B□	2	123	156	170	∅170	190	115	165	163	122	103	12	53
	1/45	R88G-HPG50A451K5B□	2	123	156	170	∅170	190	115	165	163	122	103	12	53
1.5 kW	1/5	R88G-HPG32A052K0B□	2	110	133	120	∅135	135	115	115	114	84	98	12.5	35
	1/11	R88G-HPG32A112K0B□	2	110	133	120	∅135	135	115	115	114	84	98	12.5	35
	1/21	R88G-HPG32A211K5B□	2	110	133	120	∅135	135	115	115	114	84	98	12.5	35
	1/33	R88G-HPG50A332K0B□	2	123	156	170	∅170	190	115	165	163	122	103	12	53
	1/45	R88G-HPG50A451K5B□	2	123	156	170	∅170	190	115	165	163	122	103	12	53
2 kW	1/5	R88G-HPG32A052K0B□	2	110	133	120	∅135	135	115	115	114	84	98	12.5	35
	1/11	R88G-HPG32A112K0B□	2	110	133	120	∅135	135	115	115	114	84	98	12.5	35
	1/21	R88G-HPG50A212K0B□	2	123	156	170	∅170	190	115	165	163	122	103	12	53
	1/33	R88G-HPG50A332K0B□	2	123	156	170	∅170	190	115	165	163	122	103	12	53
3 kW	1/5	R88G-HPG32A053K0B□	1	107	133	120	□130	135	145	115	114	84	98	12.5	35
	1/11	R88G-HPG50A113K0B□	2	123	156	170	∅170	190	145	165	163	122	103	12	53
	1/21	R88G-HPG50A213K0B□	2	123	156	170	∅170	190	145	165	163	122	103	12	53
4 kW	1/5	R88G-HPG32A054K0B□	1	129	133	120	□130	135	145	115	114	84	98	12.5	35
	1/11	R88G-HPG50A115K0B□	1	149	156	170	□130	190	145	165	163	122	103	12	53
5 kW	1/5	R88G-HPG50A055K0B□	1	149	156	170	□130	190	145	165	163	122	103	12	53
	1/11	R88G-HPG50A115K0B□	1	149	156	170	□130	190	145	165	163	122	103	12	53

Note 1 The standard shaft type is a straight shaft.

- A model with a key and tap is indicated with J at the end of the model number (the suffix shown in the box). (Example: R88G-HPG32A052K0BJ)
- The diameter of the motor shaft insertion hole is the same as the shaft diameter of the corresponding Servomotor.
- For Servomotors with a key, remove the key before use.

● Outline drawing 1

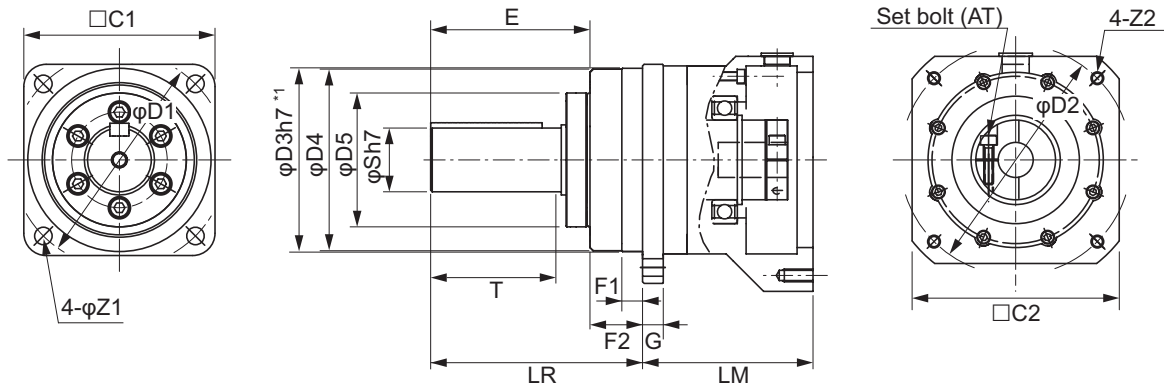

Key tap dimensions

*1 The tolerance is "h8" for R88G-HPG50□ or R88G-HPG65□.

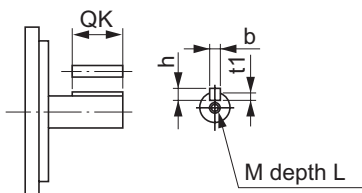

Dimensions [mm]												Model		
G	S	T	Z1	Z2	AT*1	Key				Tap				
						QK	b	h	t1	M	L			
13	40	82	11	M8 x 10	M6	70	12	8	5	M10	20	R88G-HPG32A052K0B□	1/5	1 kW
13	40	82	11	M8 x 10	M6	70	12	8	5	M10	20	R88G-HPG32A112K0B□	1/11	
13	40	82	11	M8 x 10	M6	70	12	8	5	M10	20	R88G-HPG32A211K5B□	1/21	
16	50	82	14	M8 x 10	M6	70	14	9	5.5	M10	20	R88G-HPG50A332K0B□	1/33	1.5 kW
16	50	82	14	M8 x 10	M6	70	14	9	5.5	M10	20	R88G-HPG50A451K5B□	1/45	
13	40	82	11	M8 x 10	M6	70	12	8	5	M10	20	R88G-HPG32A052K0B□	1/5	
13	40	82	11	M8 x 10	M6	70	12	8	5	M10	20	R88G-HPG32A112K0B□	1/11	2 kW
13	40	82	11	M8 x 10	M6	70	12	8	5	M10	20	R88G-HPG32A211K5B□	1/21	
16	50	82	14	M8 x 10	M6	70	14	9	5.5	M10	20	R88G-HPG50A332K0B□	1/33	
16	50	82	14	M8 x 10	M6	70	14	9	5.5	M10	20	R88G-HPG50A451K5B□	1/45	3 kW
13	40	82	11	M8 x 18	M6	70	12	8	5	M10	20	R88G-HPG32A053K0B□	1/5	
13	40	82	11	M8 x 10	M6	70	12	8	5	M10	20	R88G-HPG32A112K0B□	1/11	
16	50	82	14	M8 x 16	M6	70	14	9	5.5	M10	20	R88G-HPG50A212K0B□	1/21	4 kW
16	50	82	14	M8 x 16	M6	70	14	9	5.5	M10	20	R88G-HPG50A332K0B□	1/33	
16	50	82	14	M8 x 16	M6	70	14	9	5.5	M10	20	R88G-HPG50A451K5B□	1/45	
13	40	82	11	M8 x 25	M6	70	12	8	5	M10	20	R88G-HPG32A054K0B□	1/5	5 kW
16	50	82	14	M8 x 25	M6	70	14	9	5.5	M10	20	R88G-HPG50A115K0B□	1/11	
16	50	82	14	M8 x 25	M6	70	14	9	5.5	M10	20	R88G-HPG50A055K0B□	1/5	
16	50	82	14	M8 x 25	M6	70	14	9	5.5	M10	20	R88G-HPG50A115K0B□	1/11	

*1 Indicates set bolt.

● Outline drawing 2

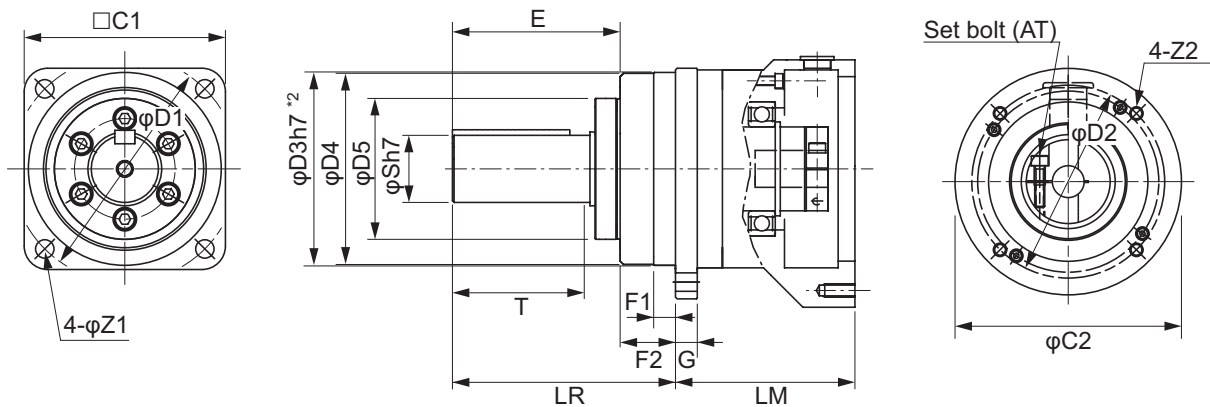

Key tap dimensions

*2 The tolerance is "h8" for R88G-HPG50□ or R88G-HPG65□.

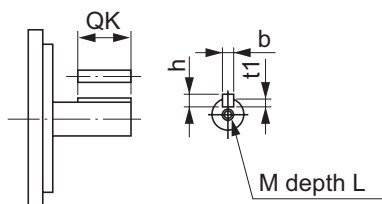

● For 2,000-r/min Servomotors (1 kW)

Model			Outline drawing	Dimensions [mm]											
				LM	LR	C1	C2	D1	D2	D3	D4	D5	E	F1	F2
1 kW	1/5	R88G-HPG32A053K0B□	1	107	133	120	□130	135	145	115	114	84	98	12.5	35
	1/11	R88G-HPG32A112K0SB□	1	107	133	120	□130	135	145	115	114	84	98	12.5	35
	1/21	R88G-HPG32A211K0SB□	1	107	133	120	□130	135	145	115	114	84	98	12.5	35
	1/33	R88G-HPG50A332K0SB□	2	123	156	170	∅170	190	145	165	163	122	103	12	53
	1/45	R88G-HPG50A451K0SB□	2	123	156	170	∅170	190	145	165	163	122	103	12	53

Note 1 The standard shaft type is a straight shaft.

- A model with a key and tap is indicated with J at the end of the model number (the suffix shown in the box). (Example: R88G-HPG32A053K0BJ)
- The diameter of the motor shaft insertion hole is the same as the shaft diameter of the corresponding Servomotor.
- For Servomotors with a key, remove the key before use.

● Outline drawing 1

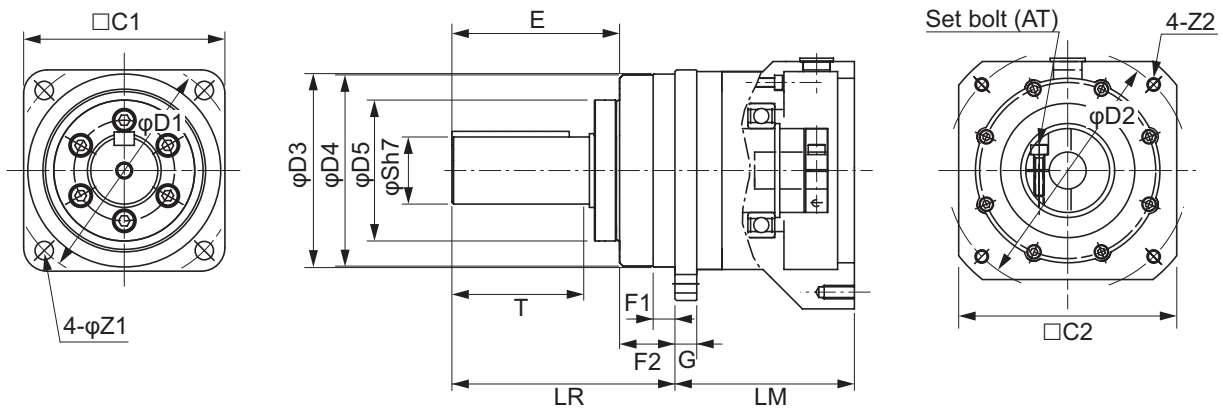

Key tap dimensions

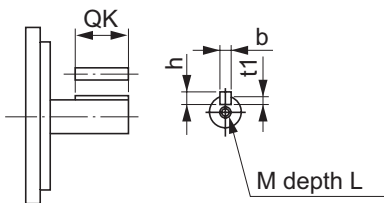

Dimensions [mm]												Model		
G	S	T	Z1	Z2	AT*1	Key				Tap				
						QK	b	h	t1	M	L			
13	40	82	11	M8 x 18	M6	70	12	8	5	M10	20	R88G-HPG32A053K0B□	1/5	1 kW
13	40	82	11	M8 x 18	M6	70	12	8	5	M10	20	R88G-HPG32A112K0SB□	1/11	
13	40	82	11	M8 x 18	M6	70	12	8	5	M10	20	R88G-HPG32A211K0SB□	1/21	
16	50	82	14	M8 x 16	M6	70	14	9	5.5	M10	20	R88G-HPG50A332K0SB□	1/33	
16	50	82	14	M8 x 16	M6	70	14	9	5.5	M10	20	R88G-HPG50A451K0SB□	1/45	

*1 Indicates set bolt.

● Outline drawing 2

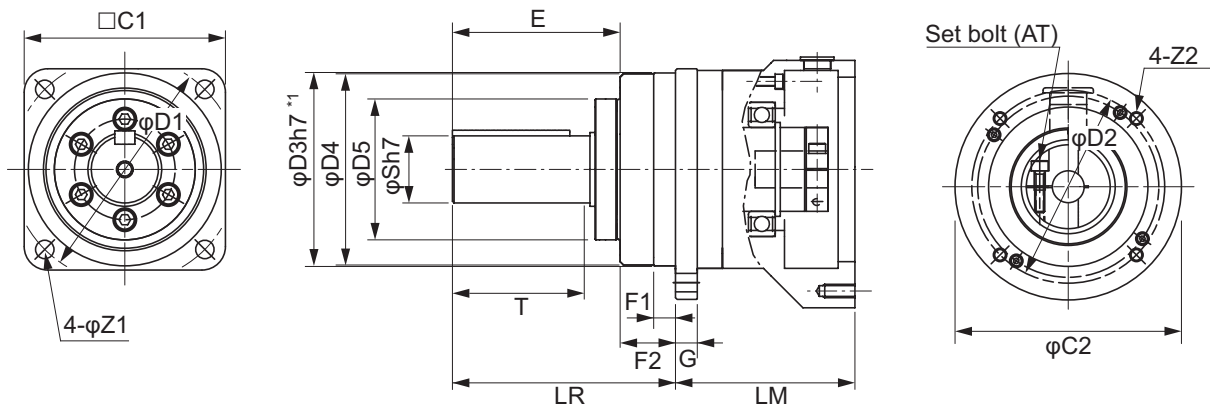

Key tap dimensions

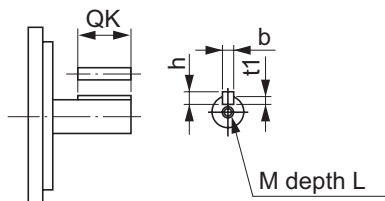

*1 The tolerance is "h8" for R88G-HPG50□ or R88G-HPG65□.

● For 2,000-r/min Servomotors (1.5 to 5 kW)

Model			Outline drawing	Dimensions [mm]											
				LM	LR	C1	C2	D1	D2	D3	D4	D5	E	F1	F2
1.5 kW	1/5	R88G-HPG32A053K0B□	1	107	133	120	□130	135	145	115	114	84	98	12.5	35
	1/11	R88G-HPG32A112K0SB□	1	107	133	120	□130	135	145	115	114	84	98	12.5	35
	1/21	R88G-HPG50A213K0B□	2	123	156	170	∅170	190	145	165	163	122	103	12	53
	1/33	R88G-HPG50A332K0SB□	2	123	156	170	∅170	190	145	165	163	122	103	12	53
2 kW	1/5	R88G-HPG32A053K0B□	1	107	133	120	□130	135	145	115	114	84	98	12.5	35
	1/11	R88G-HPG32A112K0SB□	1	107	133	120	□130	135	145	115	114	84	98	12.5	35
	1/21	R88G-HPG50A213K0B□	2	123	156	170	∅170	190	145	165	163	122	103	12	53
	1/33	R88G-HPG50A332K0SB□	2	123	156	170	∅170	190	145	165	163	122	103	12	53
3 kW	1/5	R88G-HPG32A054K0B□	1	129	133	120	□130	135	145	115	114	84	98	12.5	35
	1/11	R88G-HPG50A115K0B□	1	149	156	170	□130	190	145	165	163	122	103	12	53
	1/21	R88G-HPG50A213K0SB□	1	149	156	170	□130	190	145	165	163	122	103	12	53
	1/25	R88G-HPG65A253K0SB□	1	231	222	230	□130	260	145	220	214	168	165	12	57
4 kW	1/5	R88G-HPG50A055K0SB□	1	149	156	170	□180	190	200	165	163	122	103	12	53
	1/11	R88G-HPG50A115K0SB□	1	149	156	170	□180	190	200	165	163	122	103	12	53
	1/20	R88G-HPG65A205K0SB□	1	231	222	230	□180	260	200	220	214	168	165	12	57
	1/25	R88G-HPG65A255K0SB□	1	231	222	230	□180	260	200	220	214	168	165	12	57
5 kW	1/5	R88G-HPG50A055K0SB□	1	149	156	170	□180	190	200	165	163	122	103	12	53
	1/11	R88G-HPG50A115K0SB□	1	149	156	170	□180	190	200	165	163	122	103	12	53
	1/20	R88G-HPG65A205K0SB□	1	231	222	230	□180	260	200	220	214	168	165	12	57
	1/25	R88G-HPG65A255K0SB□	1	231	222	230	□180	260	200	220	214	168	165	12	57

Note 1 The standard shaft type is a straight shaft.

2 A model with a key and tap is indicated with J at the end of the model number (the suffix shown in the box). (Example: R88G-HPG32A053K0BJ)

3 The diameter of the motor shaft insertion hole is the same as the shaft diameter of the corresponding Servomotor.

4 For Servomotors with a key, remove the key before use.

● Outline drawing 1

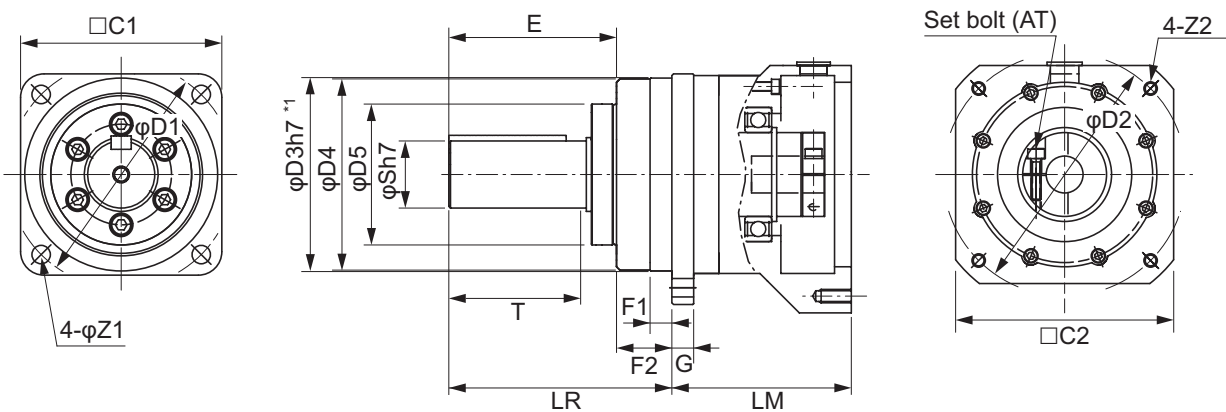

Key tap dimensions

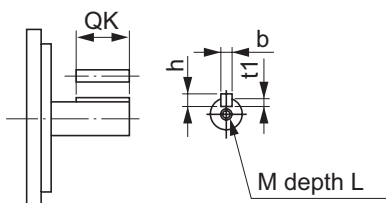

*1 The tolerance is "h8" for R88G-HPG50□ or R88G-HPG65□.

Dimensions [mm]													Model		
G	S	T	Z1	Z2	AT ^{*1}	Key				Tap					
						QK	b	h	t1	M	L				
13	40	82	11	M8 x 18	M6	70	12	8	5	M10	20	R88G-HPG32A053K0B□	1/5	1.5 kW	
13	40	82	11	M8 x 18	M6	70	12	8	5	M10	20	R88G-HPG32A112K0SB□	1/11		
16	50	82	14	M8 x 16	M6	70	14	9	5.5	M10	20	R88G-HPG50A213K0B□	1/21		
16	50	82	14	M8 x 16	M6	70	14	9	5.5	M10	20	R88G-HPG50A332K0SB□	1/33	2 kW	
13	40	82	11	M8 x 18	M6	70	12	8	5	M10	20	R88G-HPG32A053K0B□	1/5		
13	40	82	11	M8 x 18	M6	70	12	8	5	M10	20	R88G-HPG32A112K0SB□	1/11		
16	50	82	14	M8 x 16	M6	70	14	9	5.5	M10	20	R88G-HPG50A213K0B□	1/21	3 kW	
16	50	82	14	M8 x 16	M6	70	14	9	5.5	M10	20	R88G-HPG50A332K0SB□	1/33		
13	40	82	11	M8 x 25	M6	70	12	8	5	M10	20	R88G-HPG32A054K0B□	1/5		
16	50	82	14	M8 x 25	M6	70	14	9	5.5	M10	20	R88G-HPG50A115K0B□	1/11	4 kW	
16	50	82	14	M8 x 25	M6	70	14	9	5.5	M10	20	R88G-HPG50A213K0SB□	1/21		
25	80	130	18	M8 x 25	M8	110	22	14	9	M16	35	R88G-HPG65A253K0SB□	1/25		
16	50	82	14	M12 x 25	M6	70	14	9	5.5	M10	20	R88G-HPG50A055K0SB□	1/5	5 kW	
16	50	82	14	M12 x 25	M6	70	14	9	5.5	M10	20	R88G-HPG50A115K0SB□	1/11		
25	80	130	18	M12 x 25	M8	110	22	14	9	M16	35	R88G-HPG65A205K0SB□	1/20		
25	80	130	18	M12 x 25	M8	110	22	14	9	M16	35	R88G-HPG65A255K0SB□	1/25	5 kW	
16	50	82	14	M12 x 25	M6	70	14	9	5.5	M10	20	R88G-HPG50A055K0SB□	1/5		
16	50	82	14	M12 x 25	M6	70	14	9	5.5	M10	20	R88G-HPG50A115K0SB□	1/11		
25	80	130	18	M12 x 25	M8	110	22	14	9	M16	35	R88G-HPG65A205K0SB□	1/20	5 kW	
25	80	130	18	M12 x 25	M8	110	22	14	9	M16	35	R88G-HPG65A255K0SB□	1/25		

*1 Indicates set bolt.

● Outline drawing 2

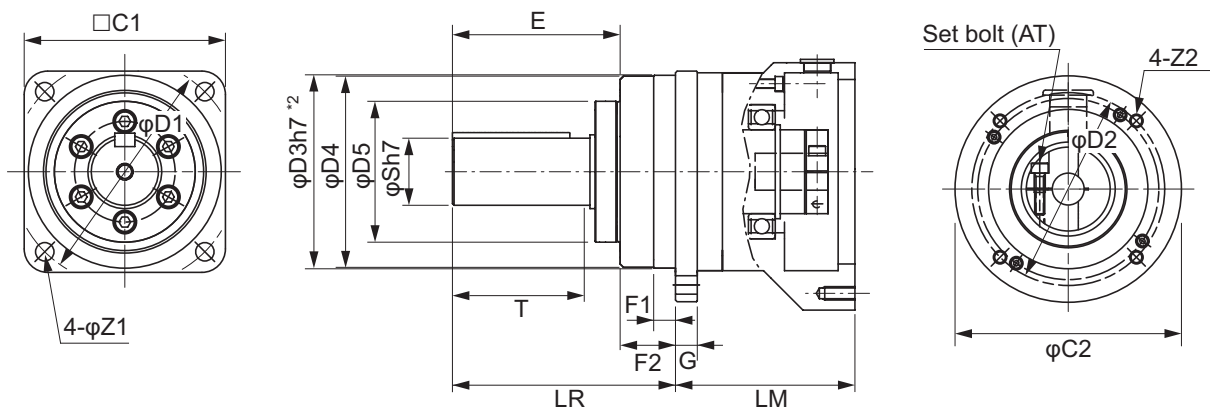

Key tap dimensions

*2 The tolerance is "h8" for R88G-HPG50□ or R88G-HPG65□.

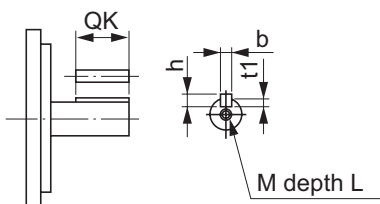

● For 1,000-r/min Servomotors (900 W to 3 kW)

Model	Outline drawing	Dimensions [mm]													
		LM	LR	C1	C2	D1	D2	D3	D4	D5	E	F1	F2		
900 W	1/5	R88G-HPG32A05900TB□	1	129	133	120	□130	135	145	115	114	84	98	12.5	35
	1/11	R88G-HPG32A11900TB□	1	129	133	120	□130	135	145	115	114	84	98	12.5	35
	1/21	R88G-HPG50A21900TB□	1	149	156	170	□130	190	145	165	163	122	103	12	53
	1/33	R88G-HPG50A33900TB□	1	149	156	170	□130	190	145	165	163	122	103	12	53
2 kW	1/5	R88G-HPG32A052K0TB□	1	129	133	120	□180	135	200	115	114	84	98	12.5	35
	1/11	R88G-HPG50A112K0TB□	1	149	156	170	□180	190	200	165	163	122	103	12	53
	1/21	R88G-HPG50A212K0TB□	1	231	222	230	□180	260	200	220	214	168	165	12	53
	1/25	R88G-HPG65A255K0SB□	1	231	222	230	□180	260	200	220	214	168	165	12	57
3 kW	1/5	R88G-HPG50A055K0SB□	1	149	156	170	□180	190	200	165	163	122	103	12	53
	1/11	R88G-HPG50A115K0SB□	1	149	156	170	□180	190	200	165	163	122	103	12	53
	1/20	R88G-HPG65A205K0SB□	1	231	222	230	□180	260	200	220	214	168	165	12	57
	1/25	R88G-HPG65A255K0SB□	1	231	222	230	□180	260	200	220	214	168	165	12	57

Note 1 The standard shaft type is a straight shaft.

- A model with a key and tap is indicated with J at the end of the model number (the suffix shown in the box). (Example: R88G-HPG32A05900TBJ)
- The diameter of the motor shaft insertion hole is the same as the shaft diameter of the corresponding Servomotor.
- For Servomotors with a key, remove the key before use.

● Outline drawing 1

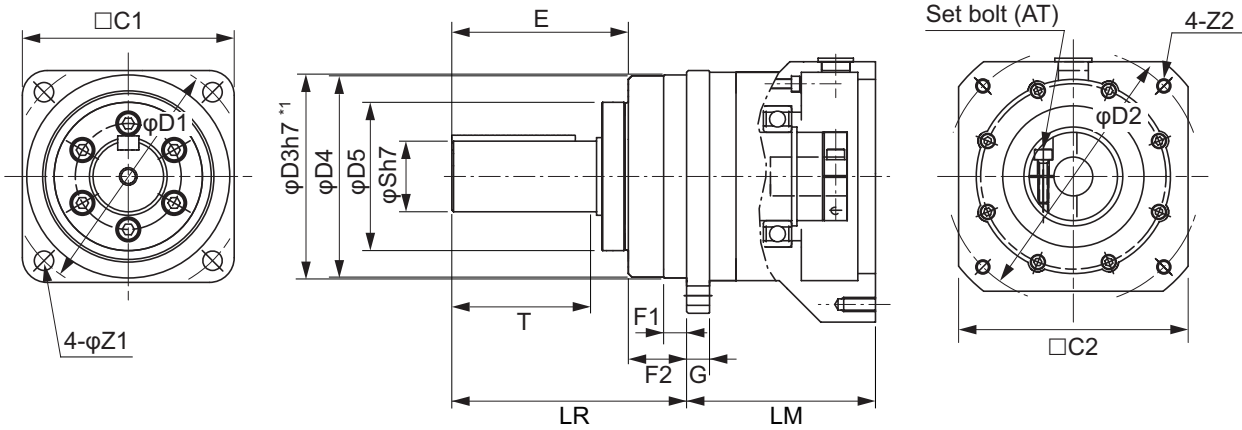

Key tap dimensions

*1 The tolerance is "h8" for R88G-HPG50□ or R88G-HPG65□.

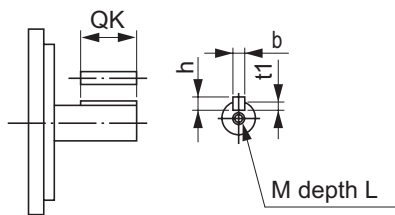

Dimensions [mm]												Model		
G	S	T	Z1	Z2	AT ^{*1}	Key				Tap				
						QK	b	h	t1	M	L			
13	40	82	11	M8 x 25	M6	70	12	8	5	M10	20	R88G-HPG32A05900TB□	1/5	900 W
13	40	82	11	M8 x 25	M6	70	12	8	5	M10	20	R88G-HPG32A11900TB□	1/11	
16	50	82	14	M8 x 25	M6	70	14	9	5.5	M10	20	R88G-HPG50A21900TB□	1/21	
16	50	82	14	M8 x 25	M6	70	14	9	5.5	M10	20	R88G-HPG50A33900TB□	1/33	
13	40	82	11	M12 x 25	M6	70	12	8	5	M10	20	R88G-HPG32A052K0TB□	1/5	2 kW
16	50	82	14	M12 x 25	M6	70	14	9	5.5	M10	20	R88G-HPG50A112K0TB□	1/11	
25	80	130	18	M12 x 25	M8	110	22	14	9	M16	35	R88G-HPG50A212K0TB□	1/21	
25	80	130	18	M12 x 25	M8	110	22	14	9	M16	35	R88G-HPG65A255K0SB□	1/25	3 kW
16	50	82	14	M12 x 25	M6	70	14	9	5.5	M10	20	R88G-HPG50A055K0SB□	1/5	
16	50	82	14	M12 x 25	M6	70	14	9	5.5	M10	20	R88G-HPG50A115K0SB□	1/11	
25	80	130	18	M12 x 25	M8	110	22	14	9	M16	35	R88G-HPG65A205K0SB□	1/20	
25	80	130	18	M12 x 25	M8	110	22	14	9	M16	35	R88G-HPG65A255K0SB□	1/25	

*1 Indicates set bolt.

Backlash: 15 Arcminutes max.

● For 3,000-r/min Servomotors

Model			Dimensions [mm]										
			LM	LR	C1	C2	D1	D2	D3	D4	E3	F	G
50 W	1/5	R88G-VRSF05B100CJ	67.5	32	40	52	46	60	50	45	10	3	6
	1/9	R88G-VRSF09B100CJ	67.5	32	40	52	46	60	50	45	10	3	6
	1/15	R88G-VRSF15B100CJ	78.0	32	40	52	46	60	50	45	10	3	6
	1/25	R88G-VRSF25B100CJ	78.0	32	40	52	46	60	50	45	10	3	6
100 W	1/5	R88G-VRSF05B100CJ	67.5	32	40	52	46	60	50	45	10	3	6
	1/9	R88G-VRSF09B100CJ	67.5	32	40	52	46	60	50	45	10	3	6
	1/15	R88G-VRSF15B100CJ	78.0	32	40	52	46	60	50	45	10	3	6
	1/25	R88G-VRSF25B100CJ	78.0	32	40	52	46	60	50	45	10	3	6
200 W	1/5	R88G-VRSF05B200CJ	72.5	32	60	52	70	60	50	45	10	3	10
	1/9	R88G-VRSF09C200CJ	89.5	50	60	78	70	90	70	62	17	3	8
	1/15	R88G-VRSF15C200CJ	100.0	50	60	78	70	90	70	62	17	3	8
	1/25	R88G-VRSF25C200CJ	100.0	50	60	78	70	90	70	62	17	3	8
400 W	1/5	R88G-VRSF05C400CJ	89.5	50	60	78	70	90	70	62	17	3	8
	1/9	R88G-VRSF09C400CJ	89.5	50	60	78	70	90	70	62	17	3	8
	1/15	R88G-VRSF15C400CJ	100.0	50	60	78	70	90	70	62	17	3	8
	1/25	R88G-VRSF25C400CJ	100.0	50	60	78	70	90	70	62	17	3	8
750 W	1/5	R88G-VRSF05C750CJ	93.5	50	80	78	90	90	70	62	17	3	10
	1/9	R88G-VRSF09D750CJ	97.5	61	80	98	90	115	90	75	18	5	10
	1/15	R88G-VRSF15D750CJ	110.0	61	80	98	90	115	90	75	18	5	10
	1/25	R88G-VRSF25D750CJ	110.0	61	80	98	90	115	90	75	18	5	10

- Note 1** The standard shaft type is a shaft with key.
2 The diameter of the motor shaft insertion hole is the same as the shaft diameter of the corresponding Servomotor.
3 For Servomotors with a key, remove the key before use.

● Outline drawing

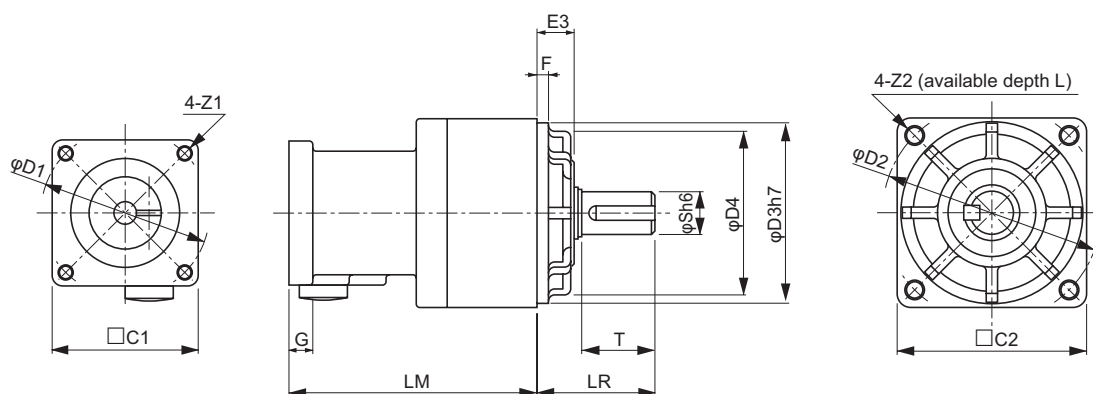

Dimensions [mm]											Model		
S	T	Z1	Z2	AT*1	L	Key							
						QK	b	h	t1				
12	20	M4	M5	M3	12	16	4	4	2.5	R88G-VRSF05B100CJ	1/5	50 W	
12	20	M4	M5	M3	12	16	4	4	2.5	R88G-VRSF09B100CJ	1/9		
12	20	M4	M5	M3	12	16	4	4	2.5	R88G-VRSF15B100CJ	1/15		
12	20	M4	M5	M3	12	16	4	4	2.5	R88G-VRSF25B100CJ	1/25		
12	20	M4	M5	M3	12	16	4	4	2.5	R88G-VRSF05B100CJ	1/5	100 W	
12	20	M4	M5	M3	12	16	4	4	2.5	R88G-VRSF09B100CJ	1/9		
12	20	M4	M5	M3	12	16	4	4	2.5	R88G-VRSF15B100CJ	1/15		
12	20	M4	M5	M3	12	16	4	4	2.5	R88G-VRSF25B100CJ	1/25		
12	20	M4	M5	M4	12	16	4	4	2.5	R88G-VRSF05B200CJ	1/5	200 W	
19	30	M4	M6	M4	20	22	6	6	3.5	R88G-VRSF09C200CJ	1/9		
19	30	M4	M6	M4	20	22	6	6	3.5	R88G-VRSF15C200CJ	1/15		
19	30	M4	M6	M4	20	22	6	6	3.5	R88G-VRSF25C200CJ	1/25		
19	30	M4	M6	M4	20	22	6	6	3.5	R88G-VRSF05C400CJ	1/5	400 W	
19	30	M4	M6	M4	20	22	6	6	3.5	R88G-VRSF09C400CJ	1/9		
19	30	M4	M6	M4	20	22	6	6	3.5	R88G-VRSF15C400CJ	1/15		
19	30	M4	M6	M4	20	22	6	6	3.5	R88G-VRSF25C400CJ	1/25		
19	30	M5	M6	M4	20	22	6	6	3.5	R88G-VRSF05C750CJ	1/5	750 W	
24	40	M5	M8	M4	20	30	8	7	4	R88G-VRSF09D750CJ	1/9		
24	40	M5	M8	M4	20	30	8	7	4	R88G-VRSF15D750CJ	1/15		
24	40	M5	M8	M4	20	30	8	7	4	R88G-VRSF25D750CJ	1/25		

*1 Indicates set bolt.

● Outline drawing

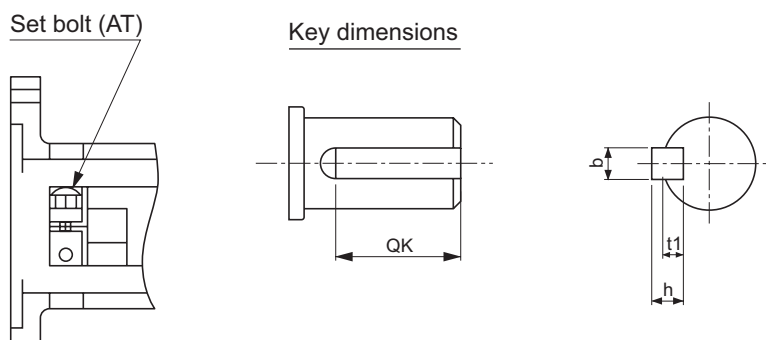

2-4-5 External Regeneration Resistor Dimensions

R88A-RR08050S/-RR080100S

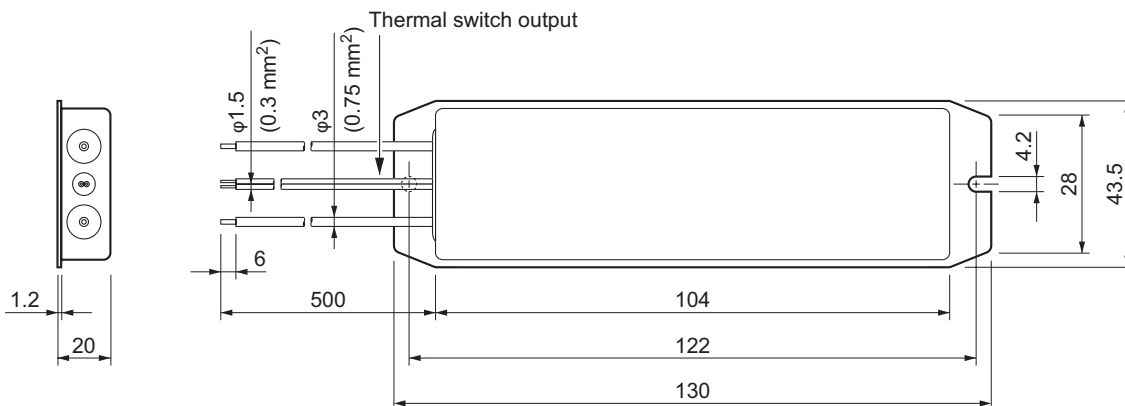

R88A-RR22047S/-RR22047S1

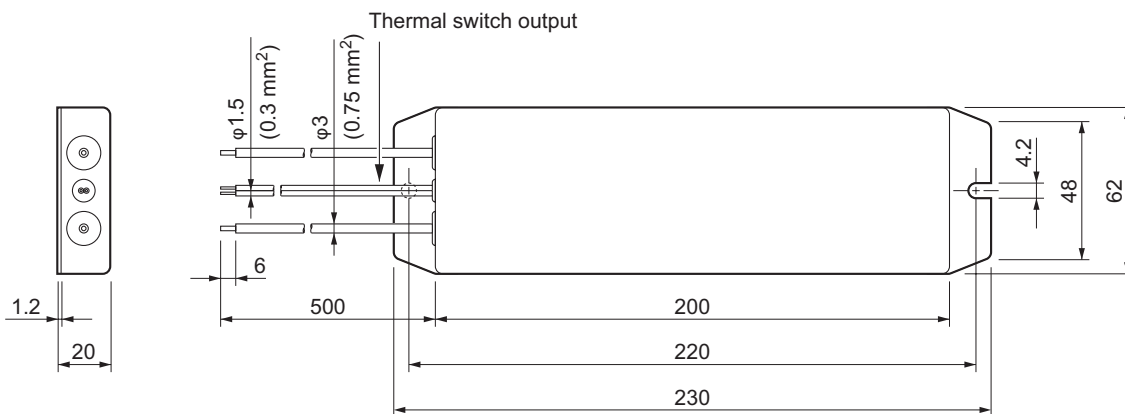

R88A-RR50020S

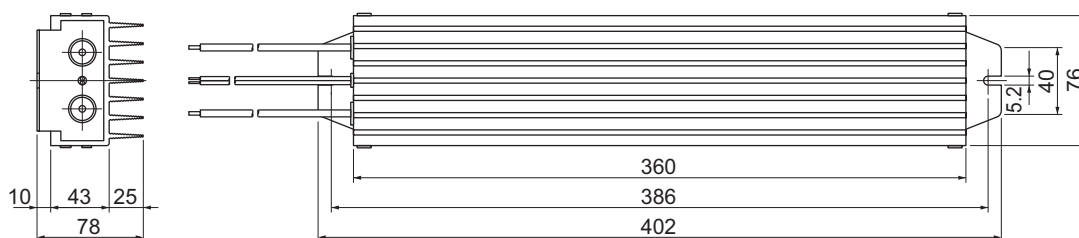

2-4-6 Reactor Dimensions

3G3AX-DL2002

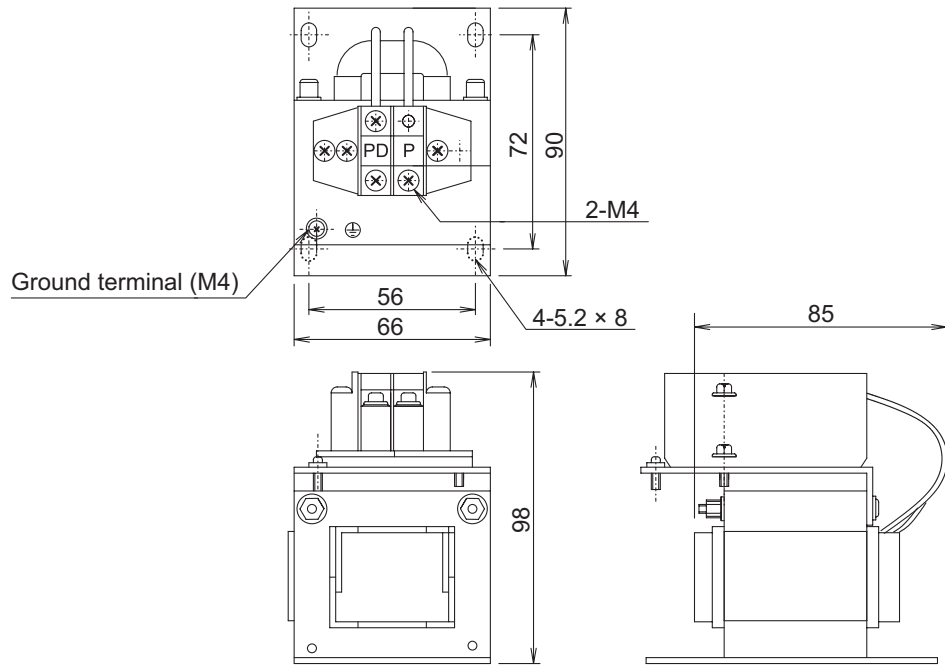

3G3AX-DL2004

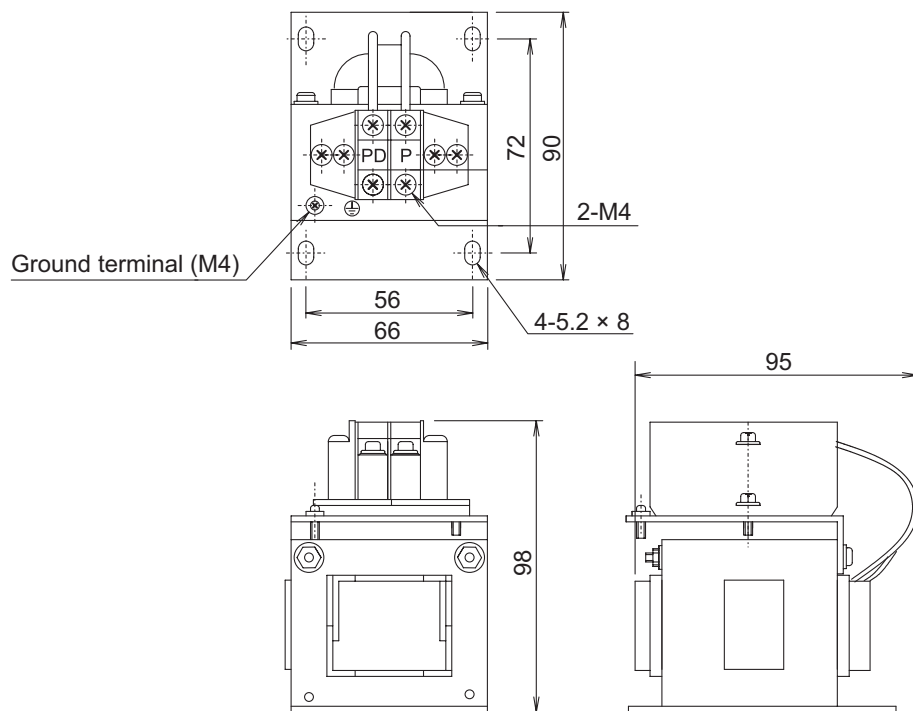

3G3AX-DL2007

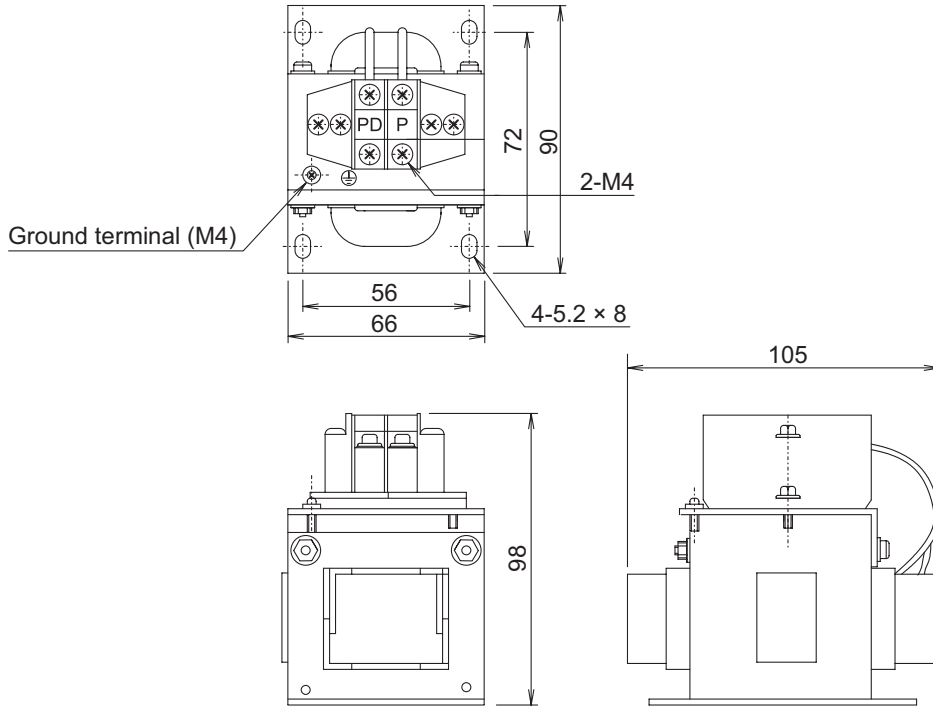

3G3AX-DL2015

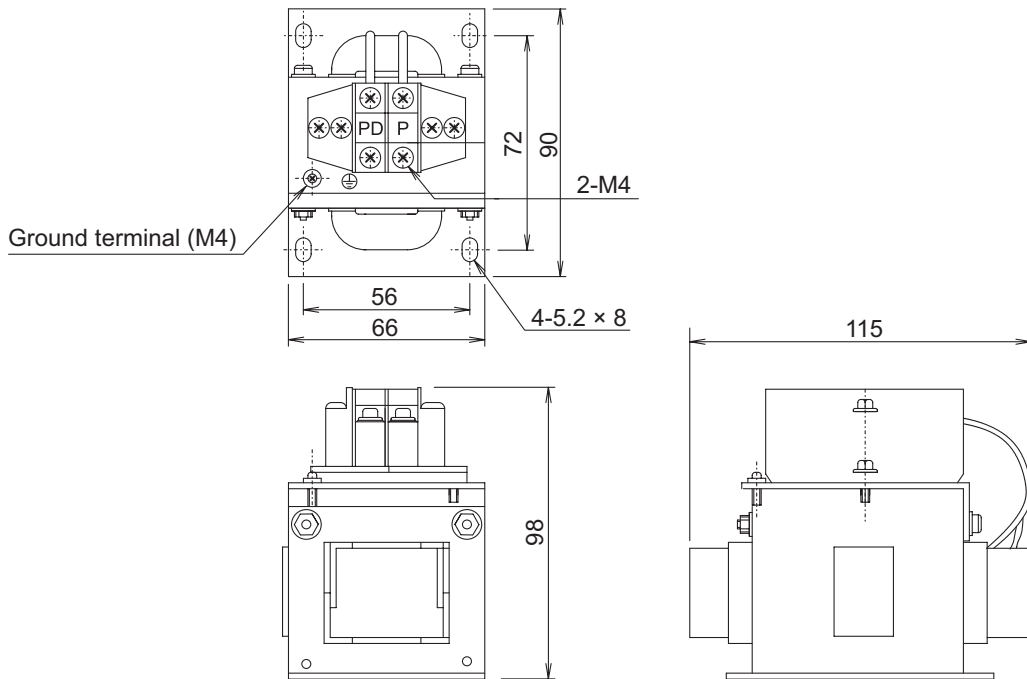

3G3AX-DL2022

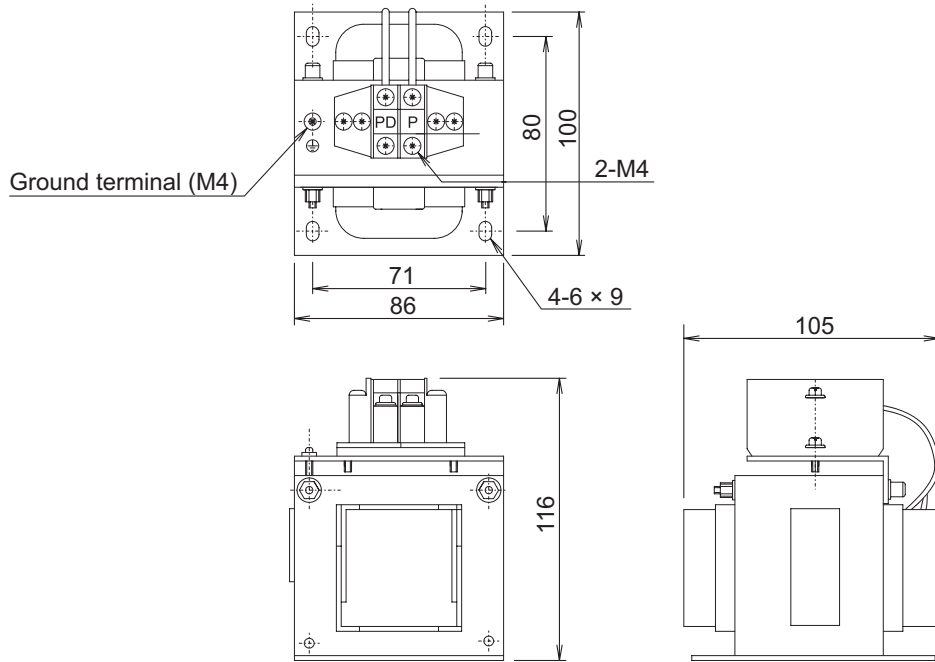

3G3AX-AL2025/-AL2055

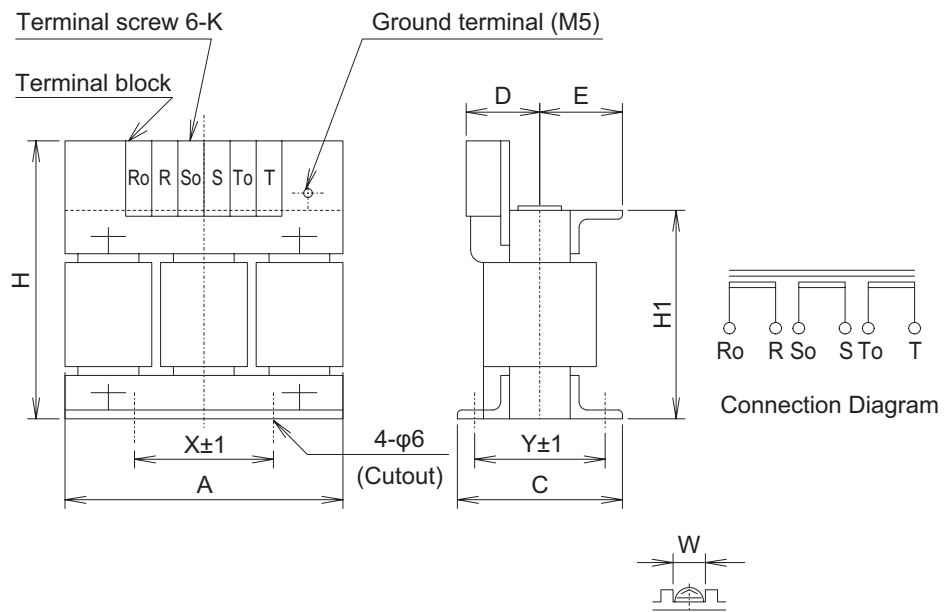

Model	Dimensions [mm]									
	A	C	D	E	H	H1	X	Y	K	W
3G3AX-AL2025	130	82	60	40	150	92	50	67	M4	9.5
3G3AX-AL2055	140	98	60	40	150	92	50	75	M4	9.5

3G3AX-AL2110

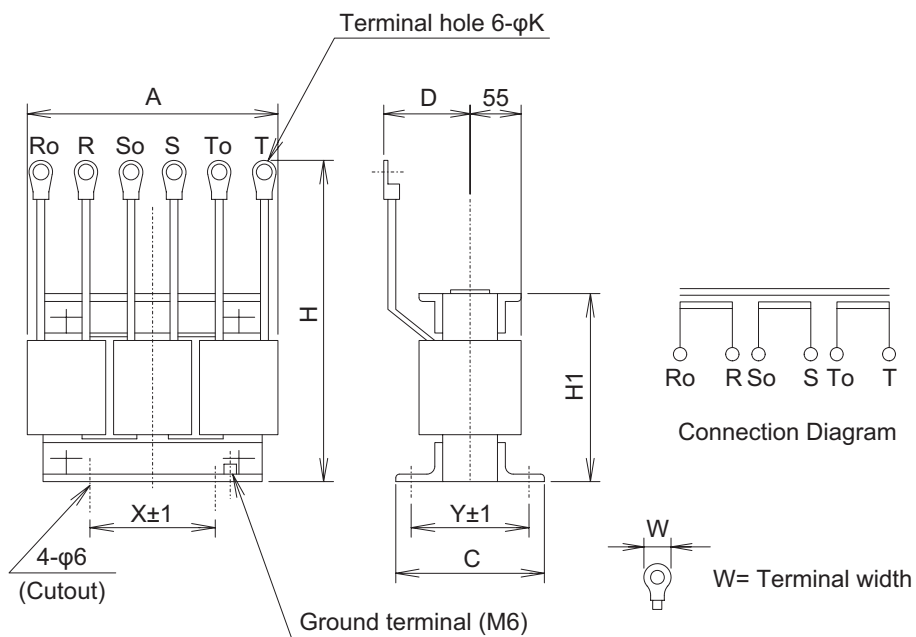

Model	Dimensions [mm]								
	A	C	D	H	H1	X	Y	K	W
3G3AX-AL2110	160	103	70	170	106	60	80	5.3	12

2-4-7 Mounting Bracket (L-brackets for Rack Mounting) Dimensions

R88A-TK01K

Top

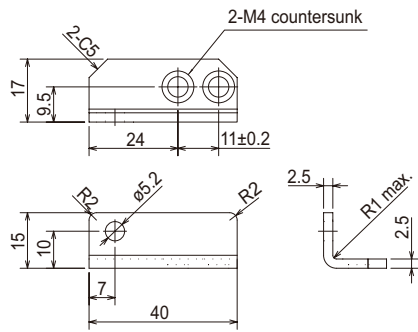

Bottom

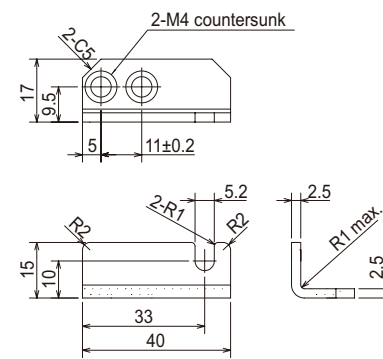

R88A-TK02K

Top

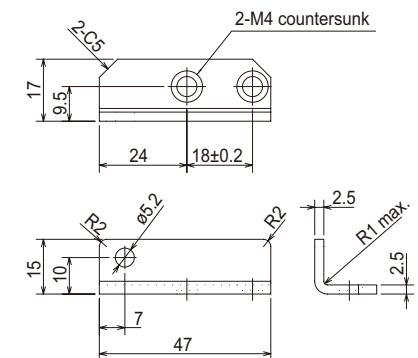

Bottom

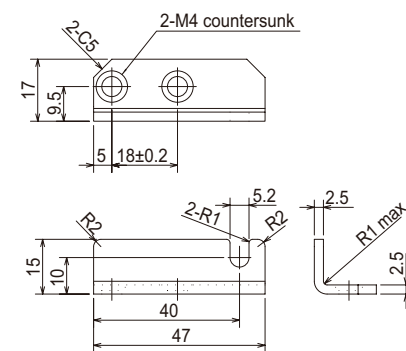

R88A-TK03K

Top

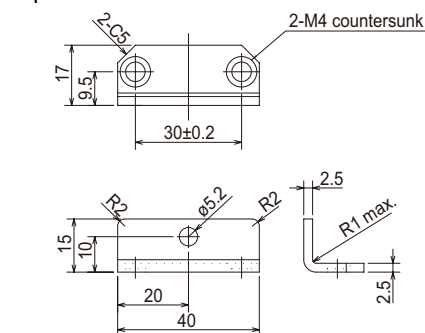

Bottom

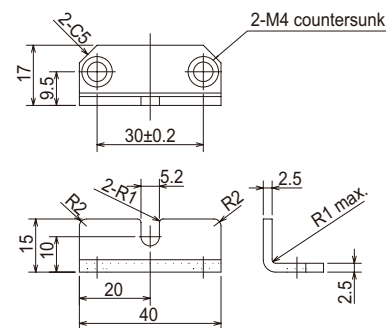

R88A-TK04K

Top

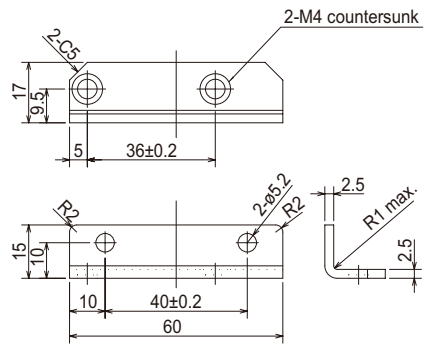

Bottom

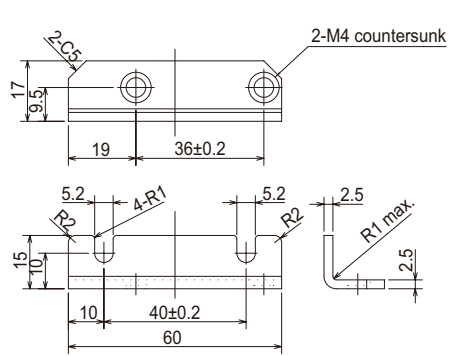

3

Specifications

This section provides the general specifications, characteristics, connector specifications, and I/O circuits of the Servo Drives as well as the general specifications, characteristics, encoder specifications of the Servomotors and other peripheral devices.

3-1	Servo Drive Specifications	3-2
3-1-1	General Specifications	3-2
3-1-2	Characteristics	3-3
3-1-3	Main Circuit and Motor Connections	3-6
3-1-4	Control I/O Connector Specifications (CN1)	3-9
3-1-5	Control Input Circuits	3-15
3-1-6	Control Input Details	3-17
3-1-7	Control Output Circuits	3-27
3-1-8	Control Output Details	3-28
3-1-9	Encoder Connector Specifications (CN2)	3-32
3-1-10	Analog Monitor Connector Specifications (CN5)	3-33
3-1-11	USB Connector Specifications (CN7)	3-34
3-2	Overload Characteristics (Electronic Thermal Function)	3-35
3-2-1	Overload Characteristics Graphs	3-35
3-3	Servomotor Specifications	3-36
3-3-1	General Specifications	3-36
3-3-2	Characteristics	3-37
3-3-3	Encoder Specifications	3-53
3-4	Decelerator Specifications	3-54
3-4-1	Models and Specifications	3-54
3-5	Cable and Connector Specifications	3-62
3-5-1	Resistance to Bending of Global Flexible Cable	3-62
3-5-2	Encoder Cable Specifications	3-64
3-5-3	Motor Power Cable Specifications	3-68
3-5-4	Connector Specifications	3-80
3-5-5	Analog Monitor Cable Specifications	3-83
3-5-6	Control Cable Specifications	3-84
3-6	Servo Relay Unit and Cable Specifications	3-96
3-6-1	Servo Relay Unit Specifications	3-96
3-6-2	Servo Drive Relay Unit Cable Specifications	3-108
3-6-3	Position Control Unit Relay Unit Cable Specifications	3-111
3-7	External Regeneration Resistor Specifications	3-122
3-7-1	External Regeneration Resistor Specifications	3-122
3-8	Reactor Specifications	3-124

3-1 Servo Drive Specifications

Select a Servo Drive that matches the Servomotor to be used. Refer to *Servo Drive and Servomotor Combination Tables* on page 2-11.

The OMNUC G5-series AC Servo Drive (Pulse-train Input Type) is a pulse-train input type device whose control mode can be switched depending on the controller in use. (By default, the control mode is set to “position control (pulse-train command).”)

3-1-1 General Specifications

Item	Specifications
Operating ambient temperature and humidity	0 to 50°C, 20% to 85% max. (with no condensation)
Storage ambient temperature and humidity	-20 to 65°C, 20% to 85% max. (with no condensation) Maximum guaranteed temperature: 80°C for 72 hours max. (with no condensation)
Operating and storage atmosphere	No corrosive gases
Vibration resistance	10 to 60 Hz and at an acceleration of 5.88 m/s ² or less (Not to be run continuously at a resonance point)
Insulation resistance	Between power supply terminals/power terminals and FG terminal: 0.5 MΩ min. (at 500 VDC)
Dielectric strength	Between power supply terminals/power terminals and FG terminal: 1,500 VAC for 1 min at 50/60 Hz
Protective structure	Built into panel

● International standard

Item	Specifications	
EC Directives	EMC Directive	EN55011, EN61000-6-2, IEC61800-3
	Low Voltage Directive	EN61800-5-1
UL standards	UL508C	
CSA standards	CSA22.2 No.14	

Note 1 The above items reflect individual evaluation testing. The results may differ under compound conditions.

2 Never perform dielectric strength or other megameter tests on the Servo Drive. Failure to follow this guideline may result in damage to the internal elements.

3 Depending on the operating conditions, some Servo Drive parts will require maintenance. For details, refer to *10-5 Periodic Maintenance* on page 10-21.

3-1-2 Characteristics

200-VAC Input Models

Item			R88D-KP01H	R88D-KP02H	R88D-KP04H	R88D-KP08H	R88D-KP10H	R88D-KP15H
Continuous output current (rms)			1.2 A	1.6A	2.6 A	4.1 A	5.9 A	9.4 A
Input power supply	Main circuit	Power supply capacity	0.5 KVA	0.5 KVA	0.9 KVA	1.3 KVA	1.8 KVA	2.3 KVA
		Power supply voltage	Single-phase or 3-phase 200 to 240 VAC (170 to 264 VAC) 50/60 Hz					
		Rated current	1.6/0.9 A ^{*1}	2.4/1.3 A ^{*1}	4.1/2.4 A ^{*1}	6.6/3.6 A ^{*1}	9.1/5.2 A ^{*1}	14.2/8.1 A ^{*1}
		Heat value ^{*2}	14.3/ 13.7 W ^{*1}	23/19 W ^{*1}	33/24 W ^{*1}	30/35.5 W ^{*1}	57/49 W ^{*1}	104/93 W ^{*1}
	Control circuit	Power supply voltage	Single-phase 200 to 240 VAC (170 to 264 VAC) 50/60 Hz					
		Heat value ^{*2}	4 W	4 W	4 W	4 W	7 W	7 W
Weight			Approx. 0.8 kg	Approx. 0.8 kg	Approx. 1.0 kg	Approx. 1.6 kg	Approx. 1.8 kg	Approx. 1.8 kg
Maximum applicable motor capacity			100 W	200 W	400 W	750 W	1 kW	1.5 kW
Applicable Servomotor	3,000 r/min	KE05030H KE10030H	KE20030H	KE40030H	KE75030H	—	KE1K030H KE1K530H	
	2,000 r/min	—	—	—	—	KE1K020H	KE1K520H	
	1,000 r/min	—	—	—	—	—	KE90010H	
Performance	Speed control range		1:5000					
	Speed variation (load characteristic)		0.01% max. from 0% to 100% (percentage of rated speed)					
	Speed variation (voltage characteristic)		0% at rated voltage ±10% (percentage of rated speed)					
	Temperature variation (temperature characteristic)		±0.01% max. (percentage of rated speed) from 0 to 50°C					
	Torque control repeatability		±1%					

*1 The first value is for single-phase input power and the second value is for 3-phase input power.

*2 The heat value is given for rated operation.

3 Specifications

Item			R88D-KP20H	R88D-KP30H	R88D-KP50H
Continuous output current (rms)			13.4 A	18.7 A	33.0 A
Input power supply	Main circuit	Power supply capacity	3.3 KVA	4.5 KVA	6.0 KVA
		Power supply voltage	3-phase 200 to 230 VAC (170 to 253 VAC) 50/60 Hz		
		Rated current	11.8 A	15.1 A	21.6 A
		Heat value *1	139 W	108 W	328 W
	Control circuit	Power supply voltage	Single-phase 200 to 230 VAC (170 to 253 VAC) 50/60 Hz		
		Heat value *1	10 W	13 W	13 W
Weight			Approx. 2.7 kg	Approx. 4.8 kg	Approx. 4.8 kg
Maximum applicable motor capacity			2 kW	3 kW	5 kW
Applicable Servomotor	3,000 r/min	KE2K030H	KE3K030H	KE4K030H KE5K030H	
	2,000 r/min	KE2K020H	KE3K020H	KE4K020H KE5K020H	
	1,000 r/min	–	KE2K010H	KE3K010H	
Performance	Speed control range		1:5000		
	Speed variation (load characteristic)		0.01% max. from 0% to 100% (percentage of rated speed)		
	Speed variation (voltage characteristic)		0% at rated voltage $\pm 10\%$ (percentage of rated speed)		
	Temperature variation (temperature characteristic)		$\pm 0.01\%$ max. (percentage of rated speed) from 0 to 50°C		
	Torque control repeatability		$\pm 2\%$		

*1 The heat value is given for rated operation.

Protective Functions

Error detected	Description
Control Power Supply Undervoltage	The DC voltage in the control power supply dropped below the specified value.
Overvoltage	The DC voltage in the main circuit power supply exceeded the specified value.
Main Power Supply Undervoltage	The DC voltage in the main circuit power supply dropped below the specified value.
Overcurrent	Overcurrent flowed through the IGBT. The Servomotor power cable is ground-faulted or short-circuited.
Servo Drive Overheat	The temperature of the Servo Drive radiator exceeded the specified value.
Overload	Operation was performed with a significantly overrated torque for a few seconds to several tens of seconds.
Regeneration Overload	The regenerative energy exceeded the regeneration absorption capacity of the Regeneration Resistor.
Encoder Communications Error	The encoder cable was disconnected.
Encoder Communications Data Error	The Servo Drive cannot establish communications with the encoder.
Error Counter Overflow	The number of accumulated pulses in the error counter exceeded the value set in Error Counter Overflow Level (Pn014).
Overspeed	The Servomotor rotation speed exceeded the maximum allowable speed.
Electronic Gear Setting Error	The settings of the Electronic Gear Ratio (Pn009 to Pn010, Pn500 to Pn503) are not appropriate.
Error Counter Overflow	The error counter value obtained with reference to the encoder pulses exceeded 2^{29} (536,870,912).
Interface I/O Setting Error	An error was detected in the interface I/O signal.
Overrun Limit Error	The Servomotor exceeded the allowable operating range set in Overrun Limit Setting (Pn514) with respect to the position command input.
Parameter Error	Data in the Parameter Save Area was corrupted when the power supply was turned ON and data was read from the EEPROM.
Parameters Destruction	The checksum did not match when the power supply was turned ON and data was read from the EEPROM.
Drive Prohibition Input Error	Both the Forward Drive Prohibition Input and Reverse Drive Prohibition Input signals turned OFF.
Encoder Phase-Z Error	A missed phase-Z pulse was detected.
Encoder CS Signal Error	A logic error was detected in the CS signal.
Motor Non-conformity	The combination of the Servomotor with the Servo Drive is not appropriate. The encoder is not connected when the power supply is turned ON.

3-1-3 Main Circuit and Motor Connections

When wiring the main circuit, use proper wire sizes, grounding systems, and noise resistance.

R88D-KP01H/-KP02H/-KP04H/-KP08H/-KP10H/-KP15H

● Main Circuit Connector Specifications (CNA)

Symbol	Name	Function
L1	Main circuit power supply input	R88D-KP□H (50 W to 1.5 kW): Single-phase 200 to 240 VAC (170 to 264 VAC) 50/60 Hz (100 W to 1.5 kW): 3-phase 200 to 240 VAC (170 to 264 VAC) 50/60 Hz Note Single-phase power supply must be connected to L1 and L3.
L2		
L3		
L1C	Control circuit power supply input	R88D-KP□H: Single-phase 200 to 240 VAC (170 to 264 VAC) 50/60 Hz
L2C		

● Motor Connector Specifications (CNB)

Symbol	Name	Function
B1	External Regeneration Resistor connection terminals	R88D-KP01H/-KP02H/-KP04H: Normally, do not short B1 and B2. Doing so may result in a malfunction. If there is high regenerative energy, connect an External Regeneration Resistor between B1 and B2. R88D-KP08H/-KP10H/-KP15H: Normally B2 and B3 are shorted. Do not short B1 and B2. Doing so may result in a malfunction. If there is high regenerative energy, remove the short-circuit bar between B2 and B3 and connect an External Regeneration Resistor between B1 and B2.
B3		
B2		
U	Motor connection terminals	Phase U
V		Phase V
W		Phase W
		These are the output terminals to the Servomotor. Be sure to wire them correctly.



Precautions for Correct Use

Tighten the ground screws to a torque of 0.7 to 0.8 N·m (M4) or 1.4 to 1.6 N·m (M5).

R88D-KP20H

● Main Circuit Connector Specifications (CNA)

Symbol	Name	Function
L1	Main circuit power supply input	R88D-KP□H (2 kW): 3-phase 200 to 230 VAC (170 to 253 VAC) 50/60 Hz Note Single-phase power supply must be connected to L1 and L3.
L2		
L3		
L1C L2C	Control circuit power supply input	R88D-KP□H: Single-phase 200 to 230 VAC (170 to 253 VAC) 50/60 Hz

● Motor Connector Specifications (CNB)

Symbol	Name	Function	
U	Motor connection terminals	Phase U	These are the output terminals to the Servomotor. Be sure to wire them correctly.
V		Phase V	
W		Phase W	

● External Regeneration Resistor Connector Specifications (CNC)

Symbol	Name	Function
B1 B3	External Regeneration Resistor connection terminals	Normally B2 and B3 are shorted. Do not short B1 and B2. Doing so may result in a malfunction. If there is high regenerative energy, remove the short-circuit bar between B2 and B3 and connect an External Regeneration Resistor between B1 and B2.
B2		
NC	Do not connect.	



Precautions for Correct Use

- Tighten the ground screws to a torque of 0.7 to 0.8 N·m (M4) or 1.4 to 1.6 N·m (M5).
- Do not connect any External Regeneration Resistors between B1 and NC.

R88D-KP30H/R88D-KP50H

● Main Circuit Terminal Block Specifications

Symbol	Name	Function	
L1	Main circuit power supply input	R88D-KP□H (3 to 5 kW): 3-phase 200 to 230 VAC (170 to 253 VAC) 50/60 Hz	
L2			
L3			
L1C	Control circuit power supply input	R88D-KP□H: Single-phase 200 to 230 VAC (170 to 253 VAC) 50/60 Hz	
L2C			
B1	External Regeneration Resistor connection terminals	Normally B2 and B3 are shorted. Do not short B1 and B2. Doing so may result in a malfunction. If there is high regenerative energy, remove the short-circuit bar between B2 and B3 and connect an External Regeneration Resistor between B1 and B2.	
B3			
B2			
NC	Do not connect.		
U	Motor connection terminals	Phase U	These are the output terminals to the Servomotor. Be sure to wire them correctly.
V		Phase V	
W		Phase W	



Precautions for Correct Use

- Tighten the terminal block screws to a torque of 0.75 N·m (M4) or 1.5 N·m (M5).
- If the torque for terminal block screws exceeds 1.2 N·m (M4) or 2.0 N·m (M5), the terminal block may be damaged.
- Tighten the fixing screw of the terminal block cover to a torque of 0.2 N·m (M3).
- Tighten the ground screws to a torque of 0.7 to 0.8 N·m (M4) or 1.4 to 1.6 N·m (M5).
- Do not connect any External Regeneration Resistors between B1 and NC.

3-1-4 Control I/O Connector Specifications (CN1)

Control I/O Signal Connections and External Signal Processing (Position Control)

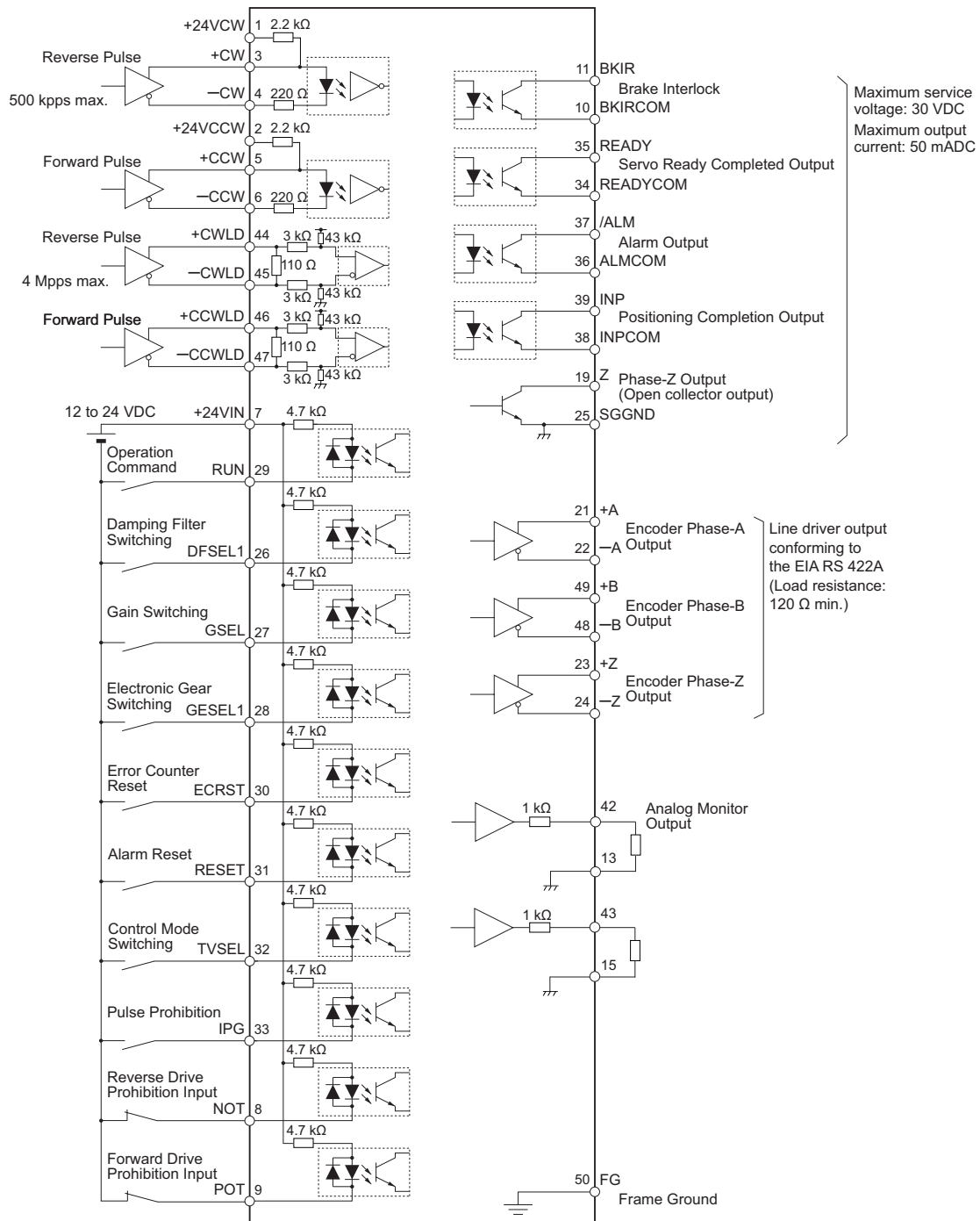

- Note 1** The input signals to pins 8, 9, and 26 to 33 and the output signals to pins 10, 11, 34, 35, 38, and 39 can be changed by parameter settings.
- 2** Use pin 25 (SGGND) to connect the GND wire if the pins 21, 22, 49, 48, 23, 24 are used for encoder output.
- 3** It is not necessary to wire input pins that are not in use.

Control Inputs (CN1)

Pin No.	Symbol	Name	Function and interface	Control mode	
				Position	Speed
1	+24 V _{CCW}	24-V Open-Collector Input for Command Pulse	These are position command pulse input terminals for both line driver and open collector connections.	√	
2	+24 V _{CCW}				
3	+CW/ +PULS/+FA	Reverse Pulse, Feed Pulse, or 90° Phase Difference Signal (phase A)	They are enabled when Command Pulse Input Selection (Pn005) is set to 0 (default setting).		
4	-CW/ -PULS/-FA				
5	+CCW/ +SIGN/+FB	Forward Pulse, Direction Signal, or 90° Phase Difference Signal (phase B)			
6	-CCW/ -SIGN/-FB				
44	+CWLD	Reverse Pulse (Input for line driver only)	These are dedicated position command pulse input terminals for the line driver output.	√	
45	-CWLD				
46	+CCWLD	Forward Pulse (Input for line driver only)	They are enabled when Command Pulse Input Selection (Pn005) is set to 1.		
47	-CCWLD				
13	SGGND	Signal Ground	This is the signal ground.		
15					
17					
7	+24VIN	12 to 24-VDC Power Supply Input	The forward input terminal for an external power supply (12 to 24 VDC) for sequence input.	√	√
8,	SI1 to SI10	Sequence Input Signal	These signals are allocated with the following functions and logics based on the values set in Input Signal Selection 1 to 10 (Pn400 to Pn409).		
9,					
26 to 33	NOT [8]	Reverse Drive Prohibition Input	This signal is for reverse drive prohibition input. It is enabled when Drive Prohibition Input Selection (Pn504) is set to 0 or 2.	√	√
	POT [9]	Forward Drive Prohibition Input	This signal is for forward drive prohibition input. It is enabled when Drive Prohibition Input Selection (Pn504) is set to 0 or 2.	√	√
	DFSEL1 [26]	Damping Filter Switching 1	This signal is enabled when Damping Filter Selection (Pn213) is set to 1 or 2. When Damping Filter Selection (Pn213) is set to 2, you can switch among four filter settings in conjunction with the Damping Filter Switching 2 (DFSEL2).	√	
	GSEL [27]	Gain Switching	This signal is enabled when Gain Switching Mode (Pn115 for position control and Pn120 for speed control) is set to 2. When OFF, Gain 1 is enabled. When ON, Gain 2 is enabled.	√	√

Pin No.	Symbol	Name	Function and interface	Control mode	
				Position	Speed
8, 9, 26 to 33	GESEL1 [28]	Electronic Gear Switching 1	This signal switches among the Electronic Gear Ratio Numerators settings. You can switch among up to four Electronic Gear Ratio Numerators settings in conjunction with the Electronic Gear Switching 2 (GESEL2).	√	
	RUN [29]	Operation Command Input	This signal turns ON the servo (to start energizing the Servomotor).	√	√
	ECRST [30]	Error Counter Reset Input	This signal resets the position error counter. The error counter can be reset either by the signal edge (set value: 0) or by the signal level (set value: 1) based on the value set in Error Counter Reset Condition Selection (Pn517).	√	
	RESET [31]	Alarm Reset Input	This signal resets an alarm state. The error counter is reset when an alarm reset signal is input. Some alarms cannot be reset with this input.	√	√
	TVSEL [32]	Control Mode Switching Input	This signal switches the control mode of the Servo Drive. It is enabled when Control Mode Selection (Pn001) is set to 3.	√	√
	IPG [33]	Pulse Prohibition Input	This signal is for position command pulse prohibition input. It is enabled when Command Pulse Prohibition Input Setting (Pn518) is set to 0.	√	
	VSEL1 [33]	Internally Set Speed Selection 1	These inputs are used for selecting the speed settings when operating the Servomotor based on internally set speeds (Pn304 to Pn311).		√
	VSEL2 [30]	Internally Set Speed Selection 2			
	VSEL3 [28]	Internally Set Speed Selection 3			
	TLSEL	Torque Limit Switching	This signal turns ON/OFF to switch the torque limit value. It is enabled when Torque Limit Selection (Pn521) is set to 3 or 6. The torque limit value and operating direction depend on the value set in this parameter.	√	√
	DFSEL2	Damping Filter Switching 2	This signal is enabled when Damping Filter Selection (Pn213) is set to 2. You can switch among four filter settings in conjunction with the Damping Filter Switching 1 (DFSEL1).	√	
GESEL2	Electronic Gear Switching 2	You can switch among up to four Electronic Gear Ratio Numerators settings in conjunction with the Electronic Gear Switching 1 (GESEL1).	√		

Pin No.	Symbol	Name	Function and interface	Control mode	
				Position	Speed
8, 9, 26 to 33	VZERO	Zero Speed Designation Input	This signal forcibly sets the speed command value to 0. It is enabled when Zero Speed Designation Selection (Pn315) is set to 1 to 3.		√
	VSIGN	Speed Command Sign Input	This signal specifies the motor rotation direction in the speed command. It is enabled when Speed Command Direction Selection (Pn301) is set to 1.		√
	STOP	Emergency Stop Input	This signal is for emergency stop input. When it is input, the Servo Drive generates an Emergency Stop Input Error and thereby stops the motor.	√	√
	JSEL	Inertia Ratio Switching Input	This signal switches between Inertia Ratio 1 and Inertia Ratio 2.	√	√

- Note that the following functions must be allocated to fixed pins.

Error Counter Reset Input (ECRST): Pin 30 only

Command Pulse Input Prohibition Input (IPG): Pin 33 only

- Each number enclosed in brackets [] shows the default pin number (allocation). (This allocation is dependent on the control mode.)

Control Outputs (CN1)

Pin No.	Symbol	Name	Function and interface	Control mode	
				Position	Speed
21	+A	Encoder Phase-A + Output	These encoder signals are output according to the values set in Encoder Dividing Numerator (Pn011). These are for line driver output (equivalent to RS422) with a maximum output frequency of 4 Mpps. These encoder signals are for phase-Z output. Line driver output (equivalent to RS422)	√	
22	-A	Encoder Phase-A - Output			
49	+B	Encoder Phase-B + Output			
48	-B	Encoder Phase-B - Output			
23	+Z	Encoder Phase-Z + Output			
24	-Z	Encoder Phase-Z - Output			
19	Z	Encoder Phase-Z Output	These encoder signals are for phase-Z output. Open collector output	√	
25	SGGND	Signal Ground	This is the signal ground.		
10, 11, 34 to 39	SO1 to SO4	Sequence Output Signal	These signals are allocated with any of the following functions based on the values set in Output Signal Selection 1 to 4 (Pn410 to 413).		
	BKIR [11]	Brake Interlock Output	This timing output signal activates the electromagnetic brake of the Servomotor.	√	√
	BKIRCOM [10]				
	READY [35]	Servo Ready Completed	This output signal indicates the Servo Drive is ready to be energized. This signal turns ON when the control/main power supply is ON and the Servo Drive is not in an alarm state.	√	√
	READYCOM [34]				

Pin No.	Symbol	Name	Function and interface	Control mode	
				Position	Speed
10,	/ALM [37]	Servo Alarm	This output signal turns OFF if an alarm occurs in the Servo Drive.	√	√
11,	ALMCOM [36]				
34 to 39	INP1 [39]	Positioning Completion Output 1	This output signal turns ON according to the condition set in Positioning Completion Condition Selection (Pn432), if the position error is equal to or less than the value set in Positioning Completion Range 1 (Pn431).	√	
	INP1COM [38]				
	TGON [39]	Motor Rotation Speed Detection Output	This output signal turns ON when the motor speed reached the value set in Rotation Speed for Motor Rotation Detection (Pn436).		√
	TGONCOM [38]				
	TLIMIT	Torque Limit Output	This output signal turns ON when the torque limit function is enabled.	√	√
	TLIMITCOM				
	ZSP	Zero Speed Detection Signal	This output turns ON when the motor rotation speed is equal to or less than the value set in the Zero Speed Detection (Pn434).	√	√
	ZSPCOM				
	VCMP	Speed Conformity Output Signal	This output signal turns ON when the command speed matches the motor speed. It turns ON when the difference between the command speed and the motor speed falls within the range set in Speed Conformity Detection Range (Pn435).		√
	VCMPCOM				
	INP2	Positioning Completion Output 2	This output signal turns ON according to the condition set in Positioning Completion Condition Selection (Pn432), if the position error is equal to or less than the value set in Positioning Completion Range 2 (Pn442).	√	
	INP2COM				
	WARN1	Warning Output 1	This output signal turns ON according to the condition set in the Warning Output Selection 1 (Pn440).	√	√
	WARN1COM				
	WARN2	Warning Output 2	This output signal turns ON according to the condition set in the Warning Output Selection 1 (Pn440).	√	√
	WARN2COM				
	P-CMD	Position Command Status Output	This output signal turns ON when the positioning command input signal is ON.	√	
	P-CMDCOM				
	ALM-ATB	Alarm Clear Attribute Output	This signal turns ON if an alarm occurs and it can be cleared.	√	√
	ALM-ATBCOM				
	V-CMD	Speed Command Status Output	This output signal turns ON when a speed command is input in the speed control mode.		√
	V-CMDCOM				

- You cannot change the allocation for servo alarm output (/ALM). (The allocation is fixed.)
- Each number enclosed in brackets [] shows the default pin number (allocation). (This allocation is dependent on the control mode.)

CN1 Pin Arrangement

2	PCOM	24-V Open-Collector Input for Command Pulse	1	PCOM	24-V Open-Collector Input for Command Pulse	27	SI4 (GSEL)	General-purpose Input 4 (Gain Switching)	26	SI3 ^{*2}	General-purpose Input 3 ^{*2}
4	-CW/ -PULS/-FA	Reverse Pulses, Feed Pulses, or 90° Phase Difference Signal (Phase A)	3	+CW/ +PULS/+FA	Reverse Pulses, Feed Pulses, or 90° Phase Difference Signal (Phase A)	29	SI6 (RUN)	General-purpose Input 6 (Operation Command)	28	SI5 ^{*2}	General-purpose Input 5 ^{*2}
6	-CCW/ -SIGN/-FB	Forward Pulse, Direction Signal, or 90° Phase Difference Signal (Phase B)	5	+CCW/ +SIGN/+FB	Forward Pulse, Direction Signal, or 90° Phase Difference Signal (Phase B)	31	SI8 (RESET)	General-purpose Input 8 (Alarm Reset Input)	30	SI7 ^{*2}	General-purpose Input 7 ^{*2}
8	SI1 (NOT)	General-purpose Input 1 (Reverse Drive Prohibition Input)	7	+24VIN	12 to 24-VDC Power Supply Input	33	SI10 ^{*2}	General-purpose Input 10 ^{*2}	32	SI9 (TVSEL)	General-purpose Input 9 (Control Mode Switching)
10	SO1COM	General-purpose Output 1 Common	9	SI2 (POT)	General-purpose Input 2 (Forward Drive Prohibition Input)	35	SO2 (READY)	General-purpose Output 2 (Servo Ready Completed Output)	34	SO2COM	General-purpose Output 2 Common
12		*1	11	SO1 (BKIR)	General-purpose Output 1 (Brake Interlock Output)	37	/ALM [SO3]	Alarm Output [General-purpose Output 3]	36	ALMCOM [SO3COM]	Alarm Output Common [General-purpose Output 3 Common]
14		*1	13	SGGND	Signal Ground	39	SO4 ^{*2}	General-purpose Output 4 ^{*2}	38	SO4COM	General-purpose Output 4 Common
16		*1	15	SGGND	Signal Ground	41		*1	40		*1
18		*1	17	SGGND	Signal Ground	43		*1	42		*1
20		*1	19	Z	Phase-Z Output (Open Collector)	45	-CWLD	Reverse Pulse (Input for line driver only)	44	+CWLD	Reverse Pulse (Input for line driver only)
22	-A	Encoder Phase-A - Output	21	+A	Encoder Phase-A + Output	47	-CCWLD	Forward Pulse (Input for line driver only)	46	+CCWLD	Forward Pulse (Input for line driver only)
24	-Z	Encoder Phase-Z - Output	23	+Z	Encoder Phase-Z + Output	49	+B	Encoder Phase-B + Output	48	-B	Encoder Phase-B - Output
			25	SGGND	Signal Ground				50		*1

Note Do not connect anything to unused pins (those indicated with *1).

The input functions for general-purpose inputs 1 to 10 (or SI1 to SI10) and the output functions for general-purpose outputs (SO1, SO2 and SO4) are determined by the user parameters Pn400 to Pn409 (Input Signal Selection 1 to 10) and Pn410 to Pn413 (Output Signal Selection 1 to 4).

The Alarm Output (/ALM) is fixed to general-purpose output 3 (those enclosed in brackets [] in the above figure).

The functions that are allocated by default are given in parentheses (). The default function allocated to each pin indicated with *2 is dependent on the control mode. Refer to 6-9 *Sequence I/O Signals* on page 6-33 for details about function allocation.

Connectors for CN1 (50 Pins)

Name	Model	Manufacturer	OMRON model number
Drive connector	52986-5079	Molex Japan	R88A-CNU11C
Cable plug	10150-3000PE	Sumitomo 3M	
Cable case (Shell kit)	10350-52A0-008		

3-1-5 Control Input Circuits

Position Command Pulse (Line Receiver Input)

For line driver and line receiver connections, position command pulses of up to 4 Mpps can be used.
(+CWLD: 44, -CWLD: 45, +CCWLD: 46, -CCWLD: 47)

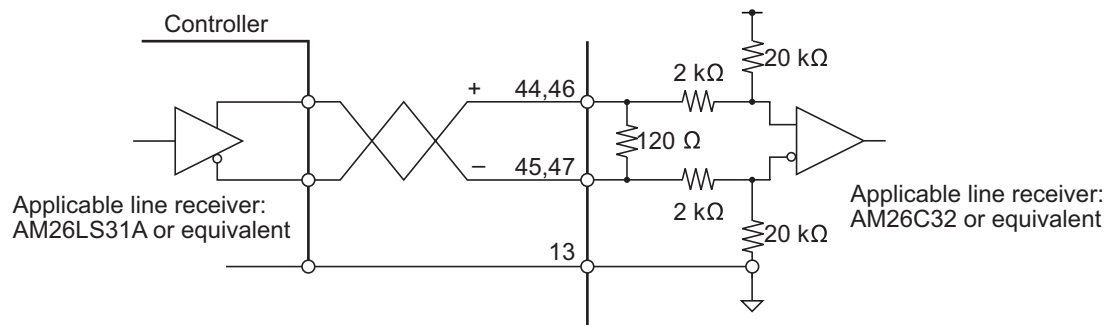

Precautions for Correct Use

The wiring length of shielded twisted-pair cables must be 10 m or shorter.

Position Command Pulse (Photocoupler Input)

For line driver and photocoupler connections, position command pulses of up to 500 kpps can be used.
(+CW: 3, -CW: 4, +CCW: 5, -CCW: 6)

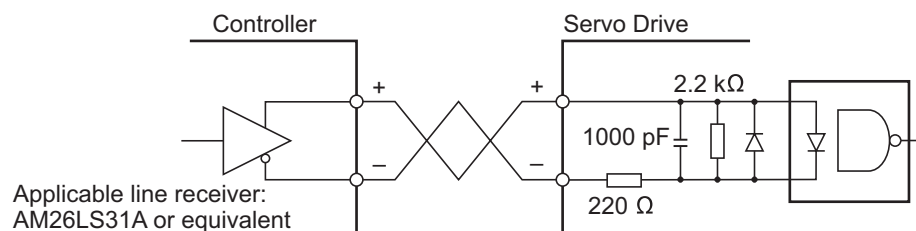

Precautions for Correct Use

The wiring length of shielded twisted-pair cables must be 10 m or shorter.

● **Open Collector Input**

- When an external 24-V power supply is used without current-limiting resistor (at 200 kpps or lower)
(+24VCW: 1, -CW: 4, +24VCCW: 2, -CCW: 6)

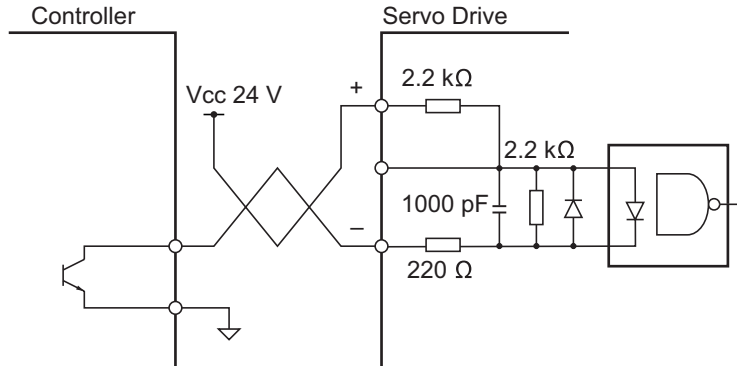

- When an external power supply is used (at 200 kpps or lower)
(+CW: 3, -CW: 4, +CCW: 5, -CCW: 6)

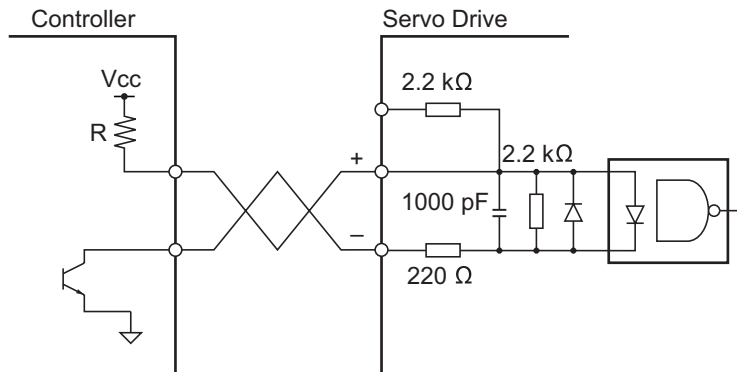

Select an appropriate Current Limit Resistor (R) for Vcc.

$$\frac{V_{cc} - 1.5}{R + 220} \approx 10 \text{ mA}$$

(7 to 15 mA)

VCC	R
24 V	2 kΩ (1/2 W)
12 V	1 kΩ (1/2 W)
5 V	0 Ω (short)



Precautions for Correct Use

The wiring length must be 3 m or shorter for open collector input.

General-purpose Input

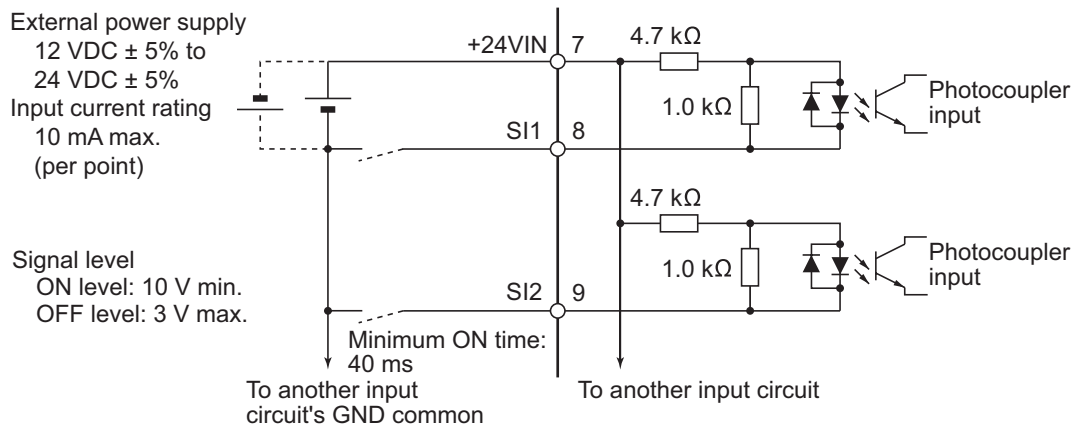

3-1-6 Control Input Details

Below are the details of the CN1 connector input pins.

High-speed Photocoupler Input

Pin 3: + Reverse Pulse (+CW), + Feed Pulse (+PULS), + Phase A (+FA)

Pin 4: – Reverse Pulse (–CW), – Feed Pulse (–PULS), – Phase A (–FA)

Pin 5: + Forward Pulse (+CCW), + Direction Signal (+SIGN), + Phase B (+FB)

Pin 6: – Forward Pulse (–CCW), – Direction Signal (–SIGN), – Phase B (–FB)

● Function

- The functions of these signals are dependent on the values set in Command Pulse Rotation Direction Switching Selection (Pn006) and Command Pulse Mode Selection (Pn007).

Pn005 Set value	Pn006 Set value	Pn007 Set value	Command pulse mode	Input pins	Motor forward command	Motor reverse command
0	0	0/2	90° Phase Difference Signal (Quadruple)	3: +FA 4: –FA 5: +FB 6: –FB		
		1	Reverse Pulse/ Forward Pulse	3: +CW 4: –CW 5: +CCW 6: –CCW		
		3	Feed Pulse/ Direction Signal	3: +PULS 4: –PULS 5: +SIGN 6: –SIGN		

- Note 1** The rotation direction is reversed when Command Pulse Rotation Direction Switching Selection (Pn006) is set to 1.
- 2** The precondition for “H” is that the photocoupler indicator is ON.

● When to Input a Command Pulse (Photocoupler Input)

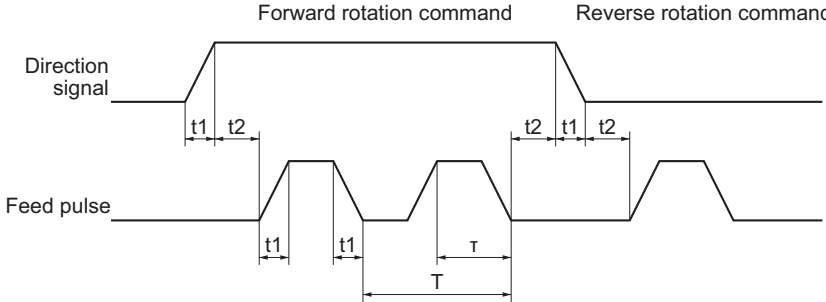
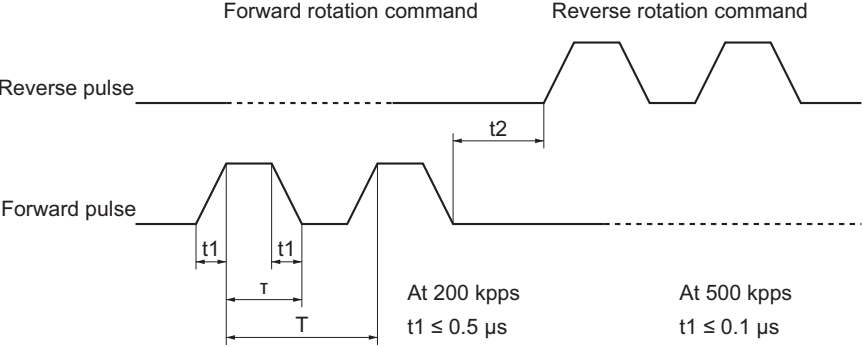
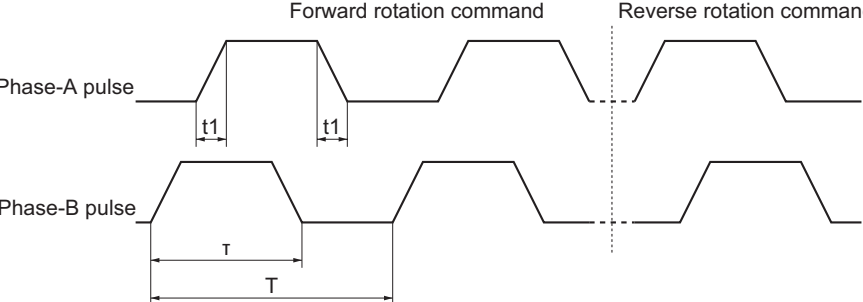
Command pulse mode	Detailed timing												
<p>Feed Pulse/Direction Signal</p> <p>Maximum input frequency Line driver: 500 kpps Open collector: 200 kpps</p>	 <table border="0" data-bbox="890 667 1353 869"> <tr> <td>At 200 kpps</td> <td>At 500 kpps</td> </tr> <tr> <td>$t1 \leq 0.5 \mu s$</td> <td>$t1 \leq 0.1 \mu s$</td> </tr> <tr> <td>$t2 > 2.5 \mu s$</td> <td>$t2 > 1.0 \mu s$</td> </tr> <tr> <td>$\tau \geq 2.5 \mu s$</td> <td>$\tau \geq 1.0 \mu s$</td> </tr> <tr> <td>$T \geq 5.0 \mu s$</td> <td>$T \geq 2.0 \mu s$</td> </tr> <tr> <td>$(\tau/T) \times 100 \leq 50 (\%)$</td> <td>$(\tau/T) \times 100 \leq 50 (\%)$</td> </tr> </table>	At 200 kpps	At 500 kpps	$t1 \leq 0.5 \mu s$	$t1 \leq 0.1 \mu s$	$t2 > 2.5 \mu s$	$t2 > 1.0 \mu s$	$\tau \geq 2.5 \mu s$	$\tau \geq 1.0 \mu s$	$T \geq 5.0 \mu s$	$T \geq 2.0 \mu s$	$(\tau/T) \times 100 \leq 50 (\%)$	$(\tau/T) \times 100 \leq 50 (\%)$
At 200 kpps	At 500 kpps												
$t1 \leq 0.5 \mu s$	$t1 \leq 0.1 \mu s$												
$t2 > 2.5 \mu s$	$t2 > 1.0 \mu s$												
$\tau \geq 2.5 \mu s$	$\tau \geq 1.0 \mu s$												
$T \geq 5.0 \mu s$	$T \geq 2.0 \mu s$												
$(\tau/T) \times 100 \leq 50 (\%)$	$(\tau/T) \times 100 \leq 50 (\%)$												
<p>Reverse Pulse/Forward Pulse</p> <p>Maximum input frequency Line driver: 500 kpps Open collector: 200 kpps</p>	 <table border="0" data-bbox="922 1182 1390 1384"> <tr> <td>At 200 kpps</td> <td>At 500 kpps</td> </tr> <tr> <td>$t1 \leq 0.5 \mu s$</td> <td>$t1 \leq 0.1 \mu s$</td> </tr> <tr> <td>$t2 > 2.5 \mu s$</td> <td>$t2 > 1.0 \mu s$</td> </tr> <tr> <td>$\tau \geq 2.5 \mu s$</td> <td>$\tau \geq 1.0 \mu s$</td> </tr> <tr> <td>$T \geq 5.0 \mu s$</td> <td>$T \geq 2.0 \mu s$</td> </tr> <tr> <td>$(\tau/T) \times 100 \leq 50 (\%)$</td> <td>$(\tau/T) \times 100 \leq 50 (\%)$</td> </tr> </table>	At 200 kpps	At 500 kpps	$t1 \leq 0.5 \mu s$	$t1 \leq 0.1 \mu s$	$t2 > 2.5 \mu s$	$t2 > 1.0 \mu s$	$\tau \geq 2.5 \mu s$	$\tau \geq 1.0 \mu s$	$T \geq 5.0 \mu s$	$T \geq 2.0 \mu s$	$(\tau/T) \times 100 \leq 50 (\%)$	$(\tau/T) \times 100 \leq 50 (\%)$
At 200 kpps	At 500 kpps												
$t1 \leq 0.5 \mu s$	$t1 \leq 0.1 \mu s$												
$t2 > 2.5 \mu s$	$t2 > 1.0 \mu s$												
$\tau \geq 2.5 \mu s$	$\tau \geq 1.0 \mu s$												
$T \geq 5.0 \mu s$	$T \geq 2.0 \mu s$												
$(\tau/T) \times 100 \leq 50 (\%)$	$(\tau/T) \times 100 \leq 50 (\%)$												
<p>90° Phase Difference Signal</p> <p>Maximum input frequency Line driver: 500 kpps Open collector: 200 kpps</p>	 <table border="0" data-bbox="922 1731 1390 1888"> <tr> <td>At 200 kpps</td> <td>At 500 kpps</td> </tr> <tr> <td>$t1 \leq 0.5 \mu s$</td> <td>$t1 \leq 0.1 \mu s$</td> </tr> <tr> <td>$\tau \geq 10 \mu s$</td> <td>$\tau \geq 4.0 \mu s$</td> </tr> <tr> <td>$T \geq 20 \mu s$</td> <td>$T \geq 8.0 \mu s$</td> </tr> <tr> <td>$(\tau/T) \times 100 \leq 50 (\%)$</td> <td>$(\tau/T) \times 100 \leq 50 (\%)$</td> </tr> </table>	At 200 kpps	At 500 kpps	$t1 \leq 0.5 \mu s$	$t1 \leq 0.1 \mu s$	$\tau \geq 10 \mu s$	$\tau \geq 4.0 \mu s$	$T \geq 20 \mu s$	$T \geq 8.0 \mu s$	$(\tau/T) \times 100 \leq 50 (\%)$	$(\tau/T) \times 100 \leq 50 (\%)$		
At 200 kpps	At 500 kpps												
$t1 \leq 0.5 \mu s$	$t1 \leq 0.1 \mu s$												
$\tau \geq 10 \mu s$	$\tau \geq 4.0 \mu s$												
$T \geq 20 \mu s$	$T \geq 8.0 \mu s$												
$(\tau/T) \times 100 \leq 50 (\%)$	$(\tau/T) \times 100 \leq 50 (\%)$												

Line Receiver Input

Pin 44: + Reverse Pulse (+CW), + Feed Pulse (+PULS), + Phase A (+FA)

Pin 45: – Reverse Pulse (–CW), – Feed Pulse (–PULS), – Phase A (–FA)

Pin 46: + Forward Pulse (+CCW), + Direction Signal (+SIGN), + Phase B (+FB)

Pin 47: – Forward Pulse (–CCW), – Direction Signal (–SIGN), – Phase B (–FB)

● Function

- The functions of these signals are dependent on the values set in Command Pulse Rotation Direction Switching Selection (Pn006) and Command Pulse Mode Selection (Pn007).

Pn005 Set value	Pn006 Set value	Pn007 Set value	Command pulse mode	Input pins	Motor forward command	Motor reverse command
1	0	0/2	90° Phase Difference Signal (Quadruple)	44: +FA 45: –FA 46: +FB 47: –FB		
		1	Reverse Pulse/ Forward Pulse	44: +CW 45: –CW 46: +CCW 47: –CCW		
		3	Feed Pulse/ Direction Signal	44: +PULS 45: –PULS 46: +SIGN 47: –SIGN		

Note The rotation direction is reversed when Command Pulse Rotation Direction Switching Selection (Pn006) is set to 1.

● When to Input a Command Pulse (Line Receiver Input)

Command pulse mode	Detailed timing
<p>Feed Pulse/Direction Signal</p> <p>Maximum input frequency Line driver: 4 Mpps</p>	<p style="text-align: center;">Forward rotation command Reverse rotation command</p> <p style="text-align: center;">Direction signal</p> <p style="text-align: center;">Feed pulse</p> <p style="text-align: center;"> $t1 \leq 20 \text{ ns}$ $t2 > 500 \text{ ns}$ $\tau \geq 250 \text{ ns}$ $T \geq 500 \text{ ns}$ $(\tau/T) \times 100 \leq 50 (\%)$ </p>
<p>Reverse Pulse/Forward Pulse</p> <p>Maximum input frequency Line driver: 4 Mpps</p>	<p style="text-align: center;">Forward rotation command Reverse rotation command</p> <p style="text-align: center;">Reverse pulse</p> <p style="text-align: center;">Forward pulse</p> <p style="text-align: center;"> $t1 \leq 20 \text{ ns}$ $t2 > 500 \text{ ns}$ $\tau \geq 250 \text{ ns}$ $T \geq 500 \text{ ns}$ $(\tau/T) \times 100 \leq 50 (\%)$ </p>
<p>90° Phase Difference Signal</p> <p>Maximum input frequency Line driver: 4 Mpps</p>	<p style="text-align: center;">Forward rotation command Reverse rotation command</p> <p style="text-align: center;">Phase-A pulse</p> <p style="text-align: center;">Phase-B pulse</p> <p style="text-align: center;"> $t1 \leq 20 \text{ ns}$ $\tau \geq 4.0 \mu\text{s}$ $T \geq 8.0 \mu\text{s}$ $(\tau/T) \times 100 \leq 50 (\%)$ </p>

Operation Command (RUN)

Pin 29: Operation Command (RUN)

This is the default allocation. The logic and allocation of input terminals (CN1 pin 1 to 8, 9, 26 to 33) can be changed using Input Signal Selection 1 to 10 (Pn400 to Pn409).

The Operation Command (RUN) must be allocated with a function. Otherwise, the servo cannot be turned ON.

● Function

This input signal turns ON the power drive circuit of the Servo Drive main circuit. Unless this input signal is ON (i.e., when the servo is OFF), the Servo Drive cannot drive the Servomotor.

Forward Drive Prohibition Input (POT) and Reverse Drive Prohibition Input (NOT)

Pin 9: Forward Drive Prohibition Input (POT)

Pin 8: Reverse Drive Prohibition Input (NOT)

● Function

These two input signals prohibit the forward and reverse rotations (over-travel) of the Servomotor.

When the Drive Prohibition Input Selection (Pn504) is set to 1, the operation when drive prohibition input is ON can be selected in the Stop Selection for Drive Prohibition Input (Pn505).

If the Drive Prohibition Input Selection (Pn504) is set to 2, Drive Prohibition Input Protection (E380) will be enabled when drive prohibition input is ON.



Precautions for Correct Use

With the default settings, both signals are disabled (i.e., drive prohibition input is disabled). For any system that requires drive prohibition input, set the Drive Prohibit Input Selection (Pn504) to either 0 or 2. The logic and allocation of input terminals (CN1 pin 1 to 8, 9, 26 to 33) can be changed using Input Signal Selection 1 to 10 (Pn400 to Pn409).

Alarm Reset Input (RESET)

Pin 31: Alarm Reset Input (RESET)

This is the default allocation. The logic and allocation of input terminals (CN1 pin 1 to 8, 9, 26 to 33) can be changed using Input Signal Selection 1 to 10 (Pn400 to Pn409).

The input logic allowed for the Alarm Reset Input (RESET) is NO contact only. (NC contact cannot be set.)

● Function

This signal is for external servo alarm reset input. (An alarm is reset at the rising edge of the input signal).

An alarm state will be cleared if the input signal remains ON for 120 ms or more.

The error counter content will also be reset when an alarm is reset, disabling the position loop. If so, remove the cause of the alarm before resuming the operation. For hazard prevention, be sure to turn OFF the Operation Command (RUN) and then input the alarm reset signal.

Some alarms cannot be reset with this input.

Error Counter Reset Input (ECRST)

Pin 30: Error Counter Reset Input (ECRST)

This is the default allocation. The function allocated to the input terminals (CN1 pin 1 to 8, 9, 26 to 33) can be changed using Input Signal Selection 1 to 10 (Pn400 to Pn409).

The Error Counter Reset Input (ECRST) must be allocated only to pin 30 (SI7). Otherwise, a Error Counter Reset Allocation Error (A332) will occur.

The input logic for the Error Counter Reset Input (ECRST) is NO contact only. (NC contact cannot be set.)

● Function

The error counter content will be reset when the Error Counter Reset Input signal turns ON, which disables the position loop.

You can use Error Counter Reset Condition Selection (Pn517) to set the status (level) signal (ON) or differential (rising edge) signal (from OFF to ON).

The duration of differential signal input must be 100 μ s or longer; the duration of status signal input must be 1 ms or longer. The counter may not be reset if the signal is shorter than this duration.

Control Mode Switching (TVSEL)

Pin 32: Control Mode Switching (TVSEL)

This is the default allocation. The logic and allocation of input terminals (CN1 pin 1 to 8, 9, 26 to 33) can be changed using Input Signal Selection 1 to 10 (Pn400 to Pn409).

● Function

When Control Mode Selection (Pn001) is set to 3, this signal enables the control mode to be switched as follows.

Pn001 set value	OFF (first control mode)	ON (second control mode)
3	Position control	Speed control (Internally set speed control)

Gain Switching (GSEL)

Pin 27: Gain Switching (GSEL)

This is the default allocation. The logic and allocation of input terminals (CN1 pin 1 to 8, 9, 26 to 33) can be changed using Input Signal Selection 1 to 10 (Pn400 to Pn409).

● Function

This signal is enabled when Gain Switching Mode (Pn115 for position control and Pn120 for speed control) is set to 2.

When the signal is OFF, Gain 1 is enabled. When the signal is ON, Gain 2 is enabled.

Damping Filter Switching 1 (DFSEL1) and Damping Filter Switching 2 (DFSEL2)

Pin 26: Damping Filter Switching 1 (DFSEL1)

No allocation: Damping Filter Switching 2 (DFSEL2)

This is the default allocation. The logic and allocation of input terminals (CN1 pin 1 to 8, 9, 26 to 33) can be changed using Input Signal Selection 1 to 10 (Pn400 to Pn409).

● Function

When Damping Filter Selection (Pn213) is set to 1 or 2, this signal enables the use of sequence signals to switch among four damping control filters.

Pn213 set value	DFSEL1	DFSEL2	Damping Filter 1	Damping Filter 2	Damping Filter 3	Damping Filter 4
1	OFF	–	Enabled		Enabled	
	ON	–		Enabled		Enabled
2	OFF	OFF	Enabled			
	ON	OFF		Enabled		
	OFF	ON			Enabled	
	ON	ON				Enabled

Electronic Gear Switching 1 (GESEL1) and Electronic Gear Switching 2 (GESEL2)

Pin 28: Electronic Gear Switching 1 (GESEL1)

No allocation: Electronic Gear Switching 2 (GESEL2)

This is the default allocation. The logic and allocation of input terminals (CN1 pin 1 to 8, 9, 26 to 33) can be changed using Input Signal Selection 1 to 10 (Pn400 to Pn409).

● Function

These two signals can be used to switch among up to four electronic gear ratio numerators.

GESEL1	GESEL2	Electronic Gear 1	Electronic Gear 2	Electronic Gear 3	Electronic Gear 4
OFF	OFF	Pn009 enabled			
ON	OFF		Pn500 enabled		
OFF	ON			Pn501 enabled	
ON	ON				Pn502 enabled

Note Electronic Gear Ratio Denominator (Pn010) is common.

Pulse Prohibition Input (IPG)

Pin 33: Pulse Prohibition Input (IPG)

This is the default allocation. Remember, however, that Command Pulse Prohibition Input Setting (Pn518) is set to 1 (disabled) by default. Before using this signal, change the value set in Pn518 to 0 (enabled). The function allocated to the input terminals (CN1 pin 1 to 8, 9, 26 to 33) can be changed using Input Signal Selection 1 to 10 (Pn400 to Pn409).

The Pulse Prohibition Input (IPG) can be allocated only to pin 33 (SI10). Otherwise, a Pulse Prohibition Input Allocation Error (A337) will occur.

● Function

This input signal enables to forcibly stop the command pulse input.

When this input signal is ON, the Servo Drive does not count pulses while ignoring the command pulse input.

Internally Set Speed Selection 1, 2 and 3 (VSEL1, 2 and 3)

Pin 33: Internally Set Speed Selection 1 (VSEL1), Pin 30: Internally Set Speed Selection 2 (VSEL2), Pin 28: Internally Set Speed Selection 3 (VSEL3)

This is the default allocation. Remember, however, that Command Speed Selection (Pn300) is set to 1 (enabled) by default. Change the value set in Command Speed Selection (Pn300) to 1 or 3 (enabled) before attempting to change the internally set speed. The logic and allocation of input terminals (CN1 pin 1 to 8, 9, 26 to 33) can be changed using Input Signal Selection 1 to 10 (Pn400 to Pn409).

● Function

The internally set speed function performs the speed control according to the internally set speed value in the parameter.

You can select the desired motor speed from up to eight internally set speed values.

Pn300 set value	VSEL1	VSEL2	VSEL3	Speed command selection
1	OFF	OFF	–	Internally Set Speed 1 (Pn304)
	ON	OFF	–	Internally Set Speed 2 (Pn305)
	OFF	ON	–	Internally Set Speed 3 (Pn306)
	ON	ON	–	Internally Set Speed 4 (Pn307)
3	OFF	OFF	OFF	Internally Set Speed 1 (Pn304)
	ON	OFF	OFF	Internally Set Speed 2 (Pn305)
	OFF	ON	OFF	Internally Set Speed 3 (Pn306)
	ON	ON	OFF	Internally Set Speed 4 (Pn307)
	OFF	OFF	ON	Internally Set Speed 5 (Pn308)
	ON	OFF	ON	Internally Set Speed 6 (Pn309)
	OFF	ON	ON	Internally Set Speed 7 (Pn310)
	ON	ON	ON	Internally Set Speed 8 (Pn311)

To use the internally set speed function, set the Zero Speed Designation Input (VZERO) to NC contact (to achieve the zero command speed when the signal is OFF). By default, the Zero Speed Designation Input (VZERO) is set to 0. Before using this signal, change the value set in Zero Speed Designation Selection (Pn315) to 1 or 2 (enabled). (Unless Zero Speed Designation Selection is enabled, the Servomotor will rotate at the speed set in Internally Set Speed 1 (Pn304) when the servo is turned ON.)

Zero Speed Designation (VZERO)

No allocation: Zero Speed Designation (VZERO)

There is no default allocation. Zero Speed Designation Selection (Pn315) is set to 0 (disabled) by default. The logic and allocation of input terminals (CN1 pin 1 to 8, 9, 26 to 33) can be changed using Input Signal Selection 1 to 10 (Pn400 to Pn409).

● Function

The Zero Speed Designation Input (VZERO) enables to forcibly set the speed command value to 0. It is enabled when Zero Speed Designation Selection (Pn315) is set to 1 to 3.

Pn315 set value	Operation when ON
0	The Zero Speed Designation Input function is disabled.
1	The speed command value is set to 0.
2	The speed command value is set to 0. The Servomotor enters the position lock mode if the motor speed is equal to or less than the value set in Position Lock Level Setting (Pn316).
3	The Servomotor enters the position lock mode if the command speed is equal to or less than the value set in Position Lock Level Setting (Pn316).

Speed Command Sign Input (VSIGN)

No allocation: Speed Command Sign Input (VSIGN)

There is no default allocation. Speed Command Direction Selection (Pn301) is set to 0 (disabled) by default. The logic and allocation of input terminals (CN1 pin 1 to 8, 9, 26 to 33) can be changed using Input Signal Selection 1 to 10 (Pn400 to Pn409).

● Function

This input signal specifies the rotation direction for the speed command.

When Speed Command Direction Selection (Pn301) is set to 1 (enabled), the rotation direction setting for the internal command speed is disabled.

Pn301 set value	VSIGN	Internal command speed	Servomotor rotation direction
0	OFF	+ (Forward rotation command: 0 to 20,000 r/min)	Forward
		– (Reverse rotation command: –20,000 to 0 r/min)	Reverse
	ON	+ (Forward rotation command: 0 to 20,000 r/min)	Forward
		– (Reverse rotation command: –20,000 to 0 r/min)	Reverse
1	OFF	+ (Forward rotation command: 0 to 20,000 r/min)	Forward
		– (Reverse rotation command: –20,000 to 0 r/min)	Forward
	ON	+ (Forward rotation command: 0 to 20,000 r/min)	Reverse
		– (Reverse rotation command: –20,000 to 0 r/min)	Reverse

Torque Limit Switching (TLSEL)

No allocation: Torque Limit Switching (TLSEL)

There is no default allocation. The logic and allocation of input terminals (CN1 pin 1 to 8, 9, 26 to 33) can be changed using Input Signal Selection 1 to 10 (Pn400 to Pn409).

● Function

This input signal switches the torque limit setting.

It is enabled when Torque Limit Selection (Pn521) is set to 3 or 6.

Pn521 set value	TLSEL	Forward	Reverse
3	OFF	Pn013 (No. 1 Torque Limit)	Pn013 (No. 1 Torque Limit)
	ON	Pn522 (No. 2 Torque Limit)	Pn522 (No. 2 Torque Limit)
6	OFF	Pn013 (No. 1 Torque Limit)	Pn522 (No. 2 Torque Limit)
	ON	Pn525 (Forward External Torque Limit)	Pn526 (Reverse External Torque Limit)

Emergency Stop Input (STOP)

No allocation: Emergency Stop Input (STOP)

There is no default allocation. The logic and allocation of input terminals (CN1 pin 1 to 8, 9, 26 to 33) can be changed using Input Signal Selection 1 to 10 (Pn400 to Pn409).

● Function

This signal is for external alarm stop input.

If the Emergency Stop (STOP) is input, the Servomotor stops according to the value set in Stop Selection for Alarm Detection (Pn510).

Inertia Ratio Switching Input (JSEL)

No allocation: Inertia Ratio Switching Input (JSEL)

This is the default allocation. The logic and allocation of input terminals (CN1 pin 1 to 8, 9, 26 to 33) can be changed using Input Signal Selection 1 to 10 (Pn400 to Pn409).

● Function

This signal switches the inertia ratio between the Inertia Ratio 1 (Pn004) and Inertia Ratio 2 (Pn613).

When this signal is OFF, the value set in Inertia Ratio 1 (Pn004) is enabled. When this signal is ON, the value set in Inertia Ratio 2 (Pn613) is enabled.

3-1-7 Control Output Circuits

Position Feedback Output

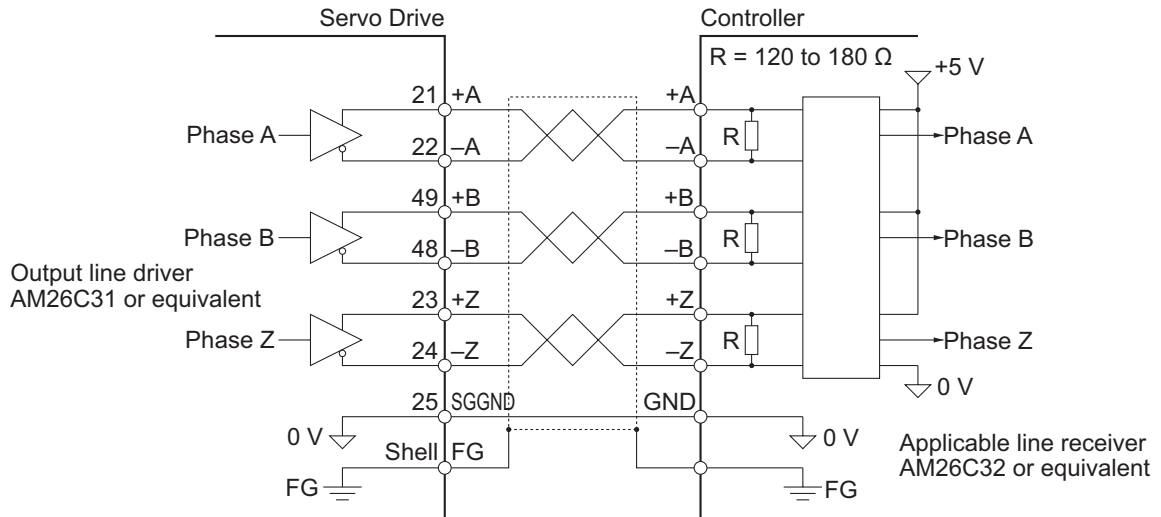

Phase-Z Output (Open Collector Output)

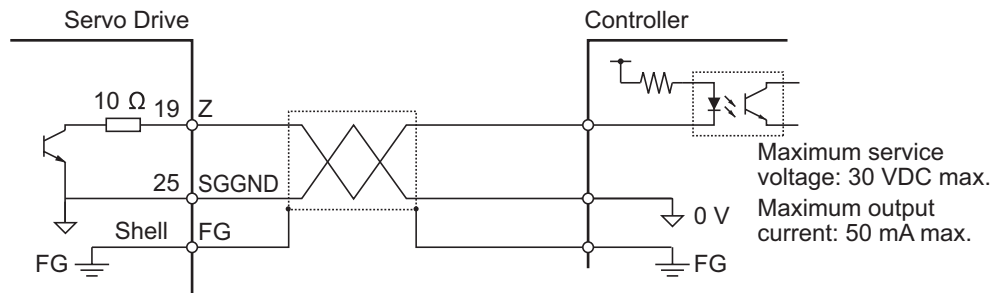

Sequence Output

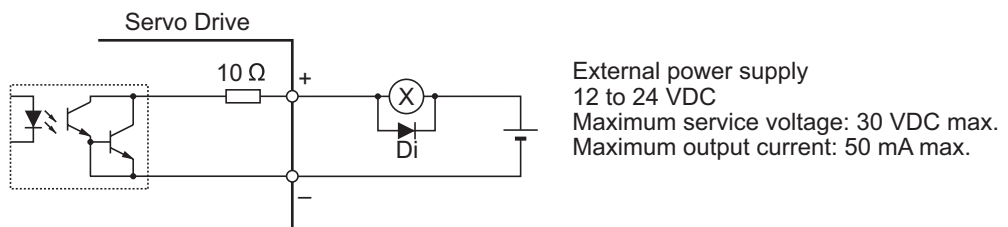

Di: Surge voltage prevention diode
(When driving a relay directly with an output signal, always insert a diode as shown in the above figure. Use a high-speed diode.)

3-1-8 Control Output Details

Control Output Sequence

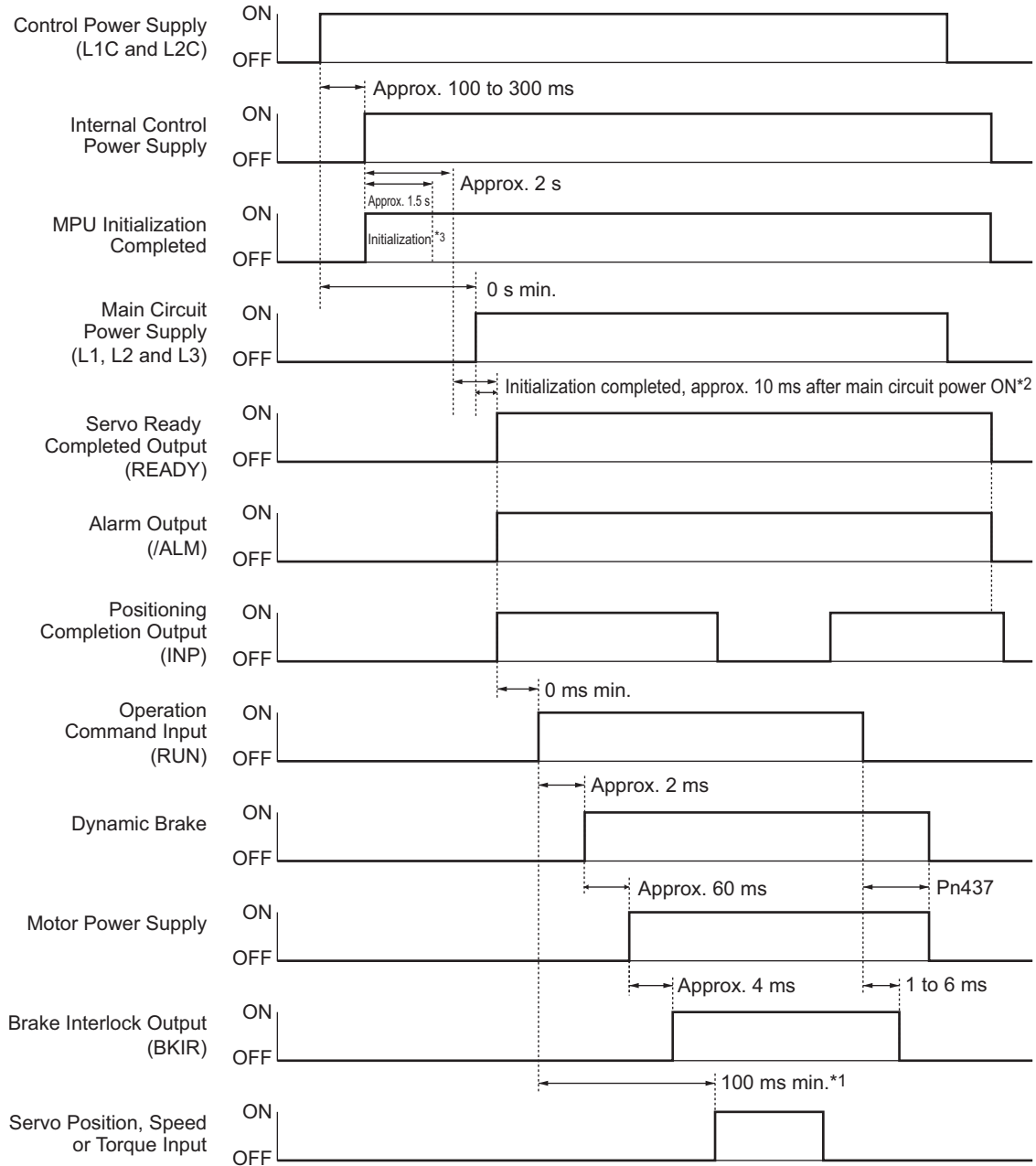

*1 Although the servo ON signal is input from the hardware in this section, it is not acceptable.

*2 The Servo Ready Completed Output (READY) turns ON only when both of these conditions are met: MPU initialization is completed and the main power supply is established.

*3 Once the internal control power supply is established, a protective function starts working about 1.5 seconds after the MPU starts initializing itself. Be sure that all I/O signals that are connected to the amplifier, especially the Forward/Reverse Drive Prohibition Input etc., are established before any protective function starts working. You can increase this time with Pn618 (Power Supply ON Initialization Time).

Encoder Outputs (Phase A, B and Z)

Pin 21: +A, Pin 22: -A, Pin 48: -B, Pin 49: +B, Pin 23: +Z, Pin 24: -Z

● Function

- These pins output the phase-A, phase-B, and phase-Z encoder signals of the Servomotor.
- The output pattern conforms to RS422.
- The line-driver ground wires for the output circuit is connected to the signal ground (SGND) without insulation.
- The maximum output frequency is 4 Mpps (quadrupled).

Brake Interlock Output (BKIR)

Pin 11: Brake Interlock Output (BKIR)

Pin 10: Brake Interlock Output Common (BKIRCOM)

This is the default allocation. The allocation of output terminals (CN1 pin 10, 11, 34, 35, 38 and 39) can be changed using Output Signal Selection 1 to 4 (Pn410 to Pn413).

● Function

The Brake Interlock Output outputs the external brake timing signal according to the values set in the Brake Timing when Stopped (Pn437) and Brake Timing during Operation (Pn438).

Servo Ready Completed Output (READY)

Pin 35: Servo Ready Completed Output (READY)

Pin 34: Servo Ready Completed Output Common (READYCOM)

This is the default allocation. The allocation of output terminals (CN1 pin 10, 11, 34, 35, 38 and 39) can be changed using Output Signal Selection 1 to 4 (Pn410 to Pn413).

● Function

This output signal indicates the Servo Drive is ready to be energized.

This signal turns ON when the control/main power supply is ON and the Servo Drive is not in an alarm state.

Alarm Output (/ALM)

Pin 37: Alarm Output (/ALM)

Pin 36: Alarm Output Common (ALMCOM)

The alarm output terminals are fixed to pins 36 and 37.

● Function

This output is turns OFF when the Servo Drive detects an error.

It is OFF when the power supply is turned ON, but it turns ON when the Servo Drive's initial processing is completed.

Positioning Completion Output 1 (INP1) and Positioning Completion Output 2 (INP2)

Pin 39: Positioning Completion Output 1 (INP1)

Pin 38: Positioning Completion Output 1 Common (INP1COM)

No allocation: Positioning Completion Output 2 (INP2)

No allocation: Positioning Completion Output 2 Common (INP2COM)

This is the default allocation. The allocation of output terminals (CN1 pin 10, 11, 34, 35, 38 and 39) can be changed using Output Signal Selection 1 to 4 (Pn410 to Pn413).

● Function

INP1 turns ON when the number of error pulses accumulated in the error counter is equal to or less than Positioning Completion Range 1 (Pn431).

INP2 turns ON when the number of error pulses accumulated in the error counter is equal to or less than Positioning Completion Range 2 (Pn442).

This output signal turns ON according to the condition set in Positioning Completion Condition Selection (Pn432).

Motor Rotation Speed Detection Output (TGON)

Pin 39: Motor Rotation Speed Detection Output (TGON)

Pin 38: Motor Rotation Speed Detection Output Common (TGONCOM)

This is the default allocation. The allocation of output terminals (CN1 pin 10, 11, 34, 35, 38 and 39) can be changed using Output Signal Selection 1 to 4 (Pn410 to Pn413).

● Function

The output signal turns ON when the Servomotor speed exceeds the value set in Rotation Speed for Motor Rotation Detection (Pn436).

Torque Limit Output (TLIMT)

No allocation: Torque Limit Output (TLIMT)

No allocation: Torque Limit Output Common (TLIMTCOM)

This is the default allocation. The allocation of output terminals (CN1 pin 10, 11, 34, 35, 38 and 39) can be changed using Output Signal Selection 1 to 4 (Pn410 to Pn413).

● Function

This output signal turns ON when the torque limit function is enabled.

Zero Speed Detection Signal (ZSP)

No allocation: Zero Speed Detection Signal (ZSP)

No allocation: Zero Speed Detection Signal Common (ZSPCOM)

This is the default allocation. The allocation of output terminals (CN1 pin 10, 11, 34, 35, 38 and 39) can be changed using Output Signal Selection 1 to 4 (Pn410 to Pn413).

● Function

This output turns ON when the motor rotation speed is equal to or less than the value set in the Zero Speed Detection (Pn434).

Speed Conformity Output Signal (VCMP)

No allocation: Speed Conformity Output Signal (VCMP)

No allocation: Speed Conformity Output Signal Common (VCMPCOM)

This is the default allocation. The allocation of output terminals (CN1 pin 10, 11, 34, 35, 38 and 39) can be changed using Output Signal Selection 1 to 4 (Pn410 to Pn413).

● Function

This output signal turns ON when the command speed matches the motor speed.

It turns ON when the difference between the command speed and the motor speed falls within the range set in Speed Conformity Detection Range (Pn435).

Warning Output 1 (WARN1)/Warning Output 2 (WARN2)

No allocation: Warning Output 1 (WARN1)/Warning Output 2 (WARN2)

No allocation: Warning Output 1 Common (WARN1COM)/Warning Output 2 Common (WARN2COM)

This is the default allocation. The allocation of output terminals (CN1 pin 10, 11, 34, 35, 38 and 39) can be changed using Output Signal Selection 1 to 4 (Pn410 to Pn413).

● Function

This signal turns ON when the condition set in the Warning Output Selection 1 (Pn440)/Warning Output Selection 2 (Pn441) is met.

Position Command Status Output (P-CMD)

No allocation: Position Command Status Output (P-CMD)

No allocation: Position Command Status Output Common (P-CMDCOM)

This is the default allocation. The allocation of output terminals (CN1 pin 10, 11, 34, 35, 38 and 39) can be changed using Output Signal Selection 1 to 4 (Pn410 to Pn413).

● Function

This output signal turns ON when the positioning command input signal is ON.

Alarm Clear Attribute Output (ALM-ATB)

No allocation: Alarm Clear Attribute Output (ALM-ATB)

No allocation: Alarm Clear Attribute Output Common (ALM-ATBCOM)

This is the default allocation. The allocation of output terminals (CN1 pin 10, 11, 34, 35, 38 and 39) can be changed using Output Signal Selection 1 to 4 (Pn410 to Pn413).

● Function

This signal turns ON if an alarm occurs and it can be cleared.

Speed Command Status Output (V-CMD)

No allocation: Speed Command Status Output (V-CMD)

No allocation: Speed Command Status Output Common (V-CMDCOM)

This is the default allocation. The allocation of output terminals (CN1 pin 10, 11, 34, 35, 38 and 39) can be changed using Output Signal Selection 1 to 4 (Pn410 to Pn413).

● Function

This output signal turns ON when a speed command is input in the speed control mode.

3-1-9 Encoder Connector Specifications (CN2)

Pin No.	Symbol	Name	Function and interface
1	E5V	Encoder power supply +5 V	Power supply output for the encoder
2	E0V	Encoder power supply GND	
3	–	Not used	Do not connect.
4	–	Not used	
5	PS+	Encoder + phase-S input	Encoder signal I/O (Serial signal)
6	PS–	Encoder – phase-S input	
Shell	FG	Frame ground	Frame ground

● Connectors for CN2 (6 Pins)

Name	Model	Manufacturer	OMRON model number
Drive connector	53460-0629	Molex Japan	R88A-CNW01R
Cable connector	55100-0670		

3-1-10 Analog Monitor Connector Specifications (CN5)

Monitor Output Signal Table

● Monitor Output (CN5)

Pin No.	Symbol	Name	Function and interface
1	AM1	Analog monitor output 1	Outputs the analog signal for the monitor. Default setting: Motor rotation speed 1 V/(500 r/min) The item and the unit can be changed using Pn416 and Pn417. The output method can be changed using Pn421.
2	AM2	Analog monitor output 2	Outputs the analog signal for the monitor. Default setting: Torque command 1 V/(33%) The item and the unit can be changed using Pn418 and Pn419. The output method can be changed using Pn421.
3	GND	Analog monitor ground	Ground for analog monitors 1, 2
4	–	Not used	Do not connect.
5	–	Not used	Do not connect.
6	–	Not used	Do not connect.

● Connectors for CN5 (6 Pins)

Name	Model	Manufacturer
Connector housing	51004-0600	Molex Japan
Connector terminal	50011-8000	Molex Japan

Monitor Output Circuit

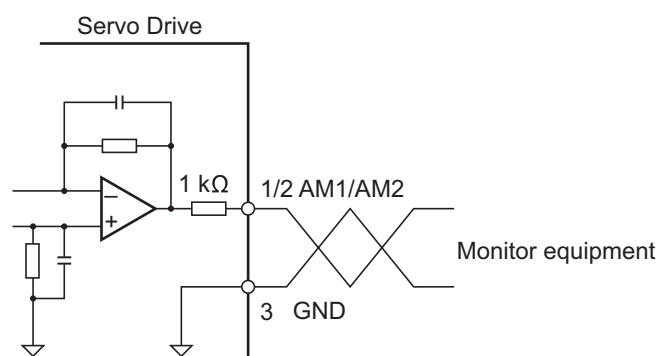

3-1-11 USB Connector Specifications (CN7)

Connecting the Servo Drive with a computer via the USB connector enables operations such as parameter setting and changing, control status monitoring, alarm status and history checking, and parameter saving and loading.

Pin No.	Symbol	Name	Function and interface
1	VBUS	USB signal terminal	Used for computer communications
2	D-		
3	D+		
4	-	Reserved for manufacturer use	Do not connect.
5	SENGND	Signal ground	Signal ground



Precautions for Correct Use

Use a commercially available USB cable that is shielded, equipped with a ferrite core for noise immunity, and supports USB2.0.

The Mini B type USB cable can be used.

3-2 Overload Characteristics (Electronic Thermal Function)

An overload protection function (electronic thermal) is built into the Servo Drive to protect the Servo Drive and Servomotor from overloading.

If an overload occurs, first eliminate the cause of the overload and then wait at least 1 minute for the motor temperature to drop before turning ON the power again.

If the alarm reset operation is repeated at short intervals, the motor windings may burn out.

3-2-1 Overload Characteristics Graphs

The following characteristics graphs show the relationship between the load ratio and electronic thermal function's operation time.

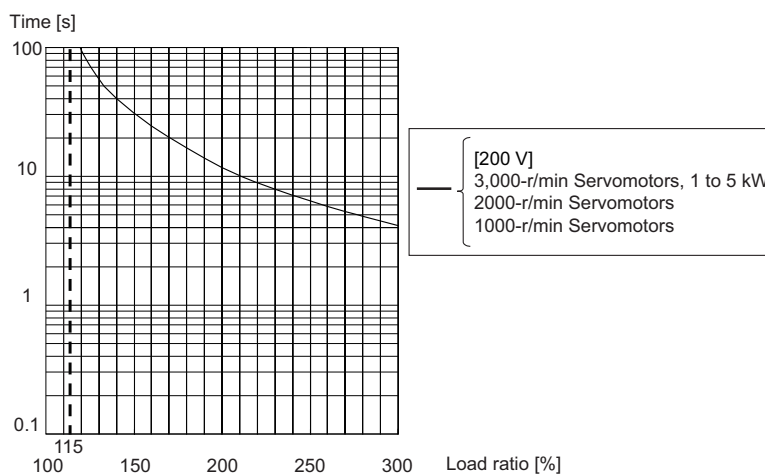
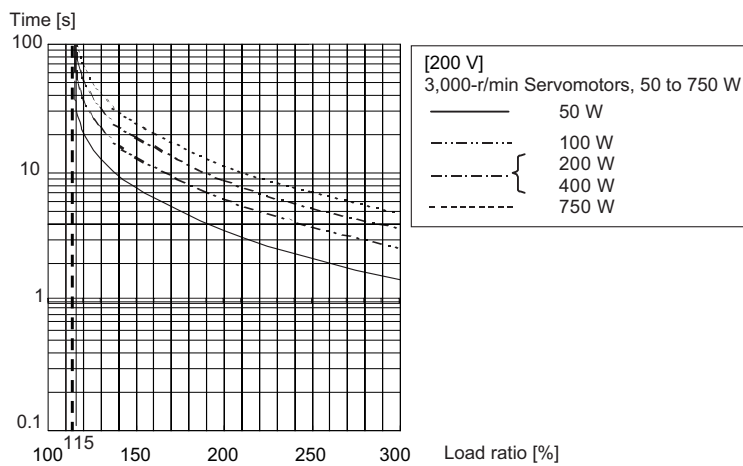

3-3 Servomotor Specifications

The following types of OMNUC G5-Series AC Servomotors (Pulse-train Input Type) are available.

- 3,000-r/min Servomotors
- 2,000-r/min Servomotors
- 1,000-r/min Servomotors

There are various options available, such as models with brake, or different shaft types.

Select a Servomotor based on the mechanical system's load conditions and the installation environment.

3-3-1 General Specifications

Item	3,000-r/min Servomotors	2,000-r/min Servomotors 3,000-r/min Servomotors	1,000-r/min Servomotors
	50 to 750 W	1 to 5 kW	900 W to 3 kW
Operating ambient temperature and humidity	0 to 40°C 20% to 85% (with no condensation)		
Storage ambient temperature and humidity	-20 to 65°C, 20% to 85% (with no condensation) Maximum guaranteed temperature: 80°C for 72 hours max. (normal humidity)		
Operating and storage atmosphere	No corrosive gases		
Vibration resistance* ¹	Acceleration of 49 m/s ² 24.5 m/s ² max. in X, Y, and Z directions when the motor is stopped		
Impact resistance	Acceleration of 98 m/s ² max. 3 times each in X, Y, and Z directions		
Insulation resistance	Between power terminal and FG terminal: 20 MΩ min. (at 500 VDC)		
Dielectric strength	1,500 VAC between power terminal and FG terminal for 1 min (voltage 200 V) 1,000 VAC between brake terminal and FG terminal for 1 min		
Insulation class	Class B	Class F	
Protective structure	IP65 (except for through-shaft parts and motor and encoder connector pins)		

● International standard

Item	3,000-r/min Servomotors	2,000-r/min Servomotors 3,000-r/min Servomotors	1,000-r/min Servomotors
	50 to 750 W	1 to 5 kW	900 W to 3 kW
EC Directives	Low Voltage Directive EN60034-1/-5		
UL standards	UL1004-1		UL1004-1
CSA standards	CSA22.2 No.100		

*1 The amplitude may be increased by mechanical resonance. In the long term, do not exceed 80% of the specified value.

Note 1 Do not use the Servomotor with cables submerged in oil or water.

2 Do not expose the cable outlet or connections to stress due to bending or its own weight.

3-3-2 Characteristics

3,000-r/min Servomotors

Model (R88M-)		Unit	200 VAC			
			KE05030H	KE10030H	KE20030H	KE40030H
Rated output ^{*1}		W	50	100	200	400
Rated torque ^{*1}		N·m	0.16	0.32	0.64	1.3
Rated rotation speed		r/min	3,000			
Maximum rotation speed		r/min	5,000			
Momentary maximum torque ^{*1}		N·m	0.48	0.95	1.91	3.8
Rated current ^{*1}		A (rms)	1.1	1.1	1.6	2.6
Momentary maximum current ^{*1}		A (rms)	4.7	4.7	6.9	11.0
Rotor inertia	Without brake	kg·m ²	0.025 x 10 ⁻⁴	0.051 x 10 ⁻⁴	0.14 x 10 ⁻⁴	0.26 x 10 ⁻⁴
	With brake	kg·m ²	0.027 x 10 ⁻⁴	0.054 x 10 ⁻⁴	0.16 x 10 ⁻⁴	0.28 x 10 ⁻⁴
Applicable load inertia		–	30 times the rotor inertia max. ^{*2}			
Torque constant ^{*1}		N·m/A	0.10±10%	0.21±10%	0.29±10%	0.36±10%
Power rate ^{*1}	Without brake	kW/s	10.4	20.1	30.3	62.5
	With brake	kW/s	9.3	19.0	25.8	57.2
Mechanical time constant	Without brake	ms	1.56	1.08	0.71	0.52
	With brake	ms	1.74	1.14	0.84	0.57
Electrical time constant		ms	0.70	0.79	2.6	3.0
Allowable radial load ^{*3}		N	68.6	68.6	245	245
Allowable thrust load ^{*3}		N	58.8	58.8	98	98
Weight	Without brake	kg	Approx. 0.32	Approx. 0.47	Approx. 0.82	Approx. 1.2
	With brake	kg	Approx. 0.53	Approx. 0.68	Approx. 1.3	Approx. 1.7
Radiator plate dimensions (material)			100 x 80 x t10 (Al)		130 x 120 x t12 (Al)	
Applicable Servo Drives (R88D-)			KP01H	KP01H	KP02H	KP04H

● Brake Specifications

Model (R88M-)		200 VAC			
Item	Unit	KE05030H	KE10030H	KE20030H	KE40030H
Brake inertia	kg·m ²	2×10^{-7}	2×10^{-7}	1.8×10^{-6}	1.8×10^{-6}
Excitation voltage ^{*4}	V	24 VDC±5%			
Power consumption (at 20°C)	W	7	7	9	9
Current consumption (at 20°C)	A	0.3	0.3	0.36	0.36
Static friction torque	N·m	0.29 min.	0.29 min.	1.27 min.	1.27 min.
Attraction time ^{*5}	ms	35 max.	35 max.	50 max.	50 max.
Release time ^{*5}	ms	20 max.	20 max.	15 max.	15 max.
Backlash		±1°			
Allowable work per braking	J	39.2	39.2	137	137
Allowable total work	J	4.9×10^3	4.9×10^3	44.1×10^3	44.1×10^3
Allowable angular acceleration	rad/s ²	30,000 max. (Speed of 2,800 r/min or more must not be changed in less than 10 ms.)			
Brake life	–	10 million times min.			
Rating	–	Continuous			
Insulation class	–	Class F			

Model (R88M-)		Unit	200 VAC		
			KE75030H	KE1K030H	KE1K530H
Rated output ^{*1}		W	750	1,000	1,500
Rated torque ^{*1}		N·m	2.4	3.18	4.77
Rated rotation speed		r/min	3,000		
Maximum rotation speed		r/min	4,500	5,000	
Momentary maximum torque ^{*1}		N·m	7.1	9.55	14.3
Rated current ^{*1}		A (rms)	4.0	6.6	8.2
Momentary maximum current ^{*1}		A (rms)	17.0	28	35
Rotor inertia	Without brake	kg·m ²	0.87×10^{-4}	2.03×10^{-4}	2.84×10^{-4}
	With brake	kg·m ²	0.97×10^{-4}	2.35×10^{-4}	3.17×10^{-4}
Applicable load inertia		–	20 times the rotor inertia max. ^{*2}	15 times the rotor inertia max. ^{*2}	
Torque constant ^{*1}		N·m/A	0.45±10%	0.37	0.45
Power rate ^{*1}	Without brake	kW/s	66.0	49.8	80.1
	With brake	kW/s	58.9	43.0	71.8
Mechanical time constant	Without brake	ms	0.45	0.61	0.49
	With brake	ms	0.51	0.71	0.55
Electrical time constant		ms	4.6	5.8	6.3
Allowable radial load ^{*3}		N	392	490	490
Allowable thrust load ^{*3}		N	147	196	196
Weight	Without brake	kg	Approx. 2.3	Approx. 3.5	Approx. 4.4
	With brake	kg	Approx. 3.1	Approx. 4.5	Approx. 5.4
Radiator plate dimensions (material)			170 x 160 x t12 (Al)	320 x 300 x t20 (Al)	
Applicable Servo Drives (R88D-)			KP08H	KP15H	KP15H

● Brake Specifications

Model (R88M-)		200 VAC		
Item	Unit	KE75030H	KE1K030H	KE1K530H
Brake inertia	kg·m ²	7.5×10^{-6}	0.33×10^{-4}	0.33×10^{-4}
Excitation voltage ^{*4}	V	24 VDC±5%	24 VDC±10%	
Power consumption (at 20°C)	W	10	19	19
Current consumption (at 20°C)	A	0.42	0.81±10%	0.81±10%
Static friction torque	N·m	2.45 min.	7.8 min.	7.8 min.
Attraction time ^{*5}	ms	70 max.	50 max.	50 max.
Release time ^{*5}	ms	20 max. ^{*6}	15 max. ^{*6}	15 max. ^{*6}
Backlash		±1°		
Allowable work per braking	J	196	392	392
Allowable total work	J	1.47×10^5	4.9×10^5	4.9×10^5
Allowable angular acceleration	rad/s ²	10,000		
Brake life	–	10 million times min.		
Rating	–	Continuous		
Insulation class	–	Class F		

Model (R88M-)		200 VAC				
Item	Unit	KE2K030H	KE3K030H	KE4K030H	KE5K030H	
Rated output ^{*1}	W	2,000	3,000	4,000	5,000	
Rated torque ^{*1}	N·m	6.37	9.55	12.7	15.9	
Rated rotation speed	r/min	3,000				
Maximum rotation speed	r/min	5,000		4,500	4,500	
Momentary maximum torque ^{*1}	N·m	19.1	28.6	38.2	47.7	
Rated current ^{*1}	A (rms)	11.3	18.1	19.6	24.0	
Momentary maximum current ^{*1}	A (rms)	48	77	83	102	
Rotor inertia	Without brake	kg·m ²	3.68×10^{-4}	6.50×10^{-4}	12.9×10^{-4}	17.4×10^{-4}
	With brake	kg·m ²	4.01×10^{-4}	7.85×10^{-4}	14.2×10^{-4}	18.6×10^{-4}
Applicable load inertia	–	15 times the rotor inertia max. ^{*2}				
Torque constant ^{*1}	N·m/A	0.44	0.41	0.49	0.49	
Power rate ^{*1}	Without brake	kW/s	110	140	126	146
	With brake	kW/s	101	116	114	136
Mechanical time constant	Without brake	ms	0.44	0.41	0.51	0.50
	With brake	ms	0.48	0.49	0.56	0.54
Electrical time constant	ms	6.7	11	12	13	
Allowable radial load ^{*3}	N	490	490	784	784	
Allowable thrust load ^{*3}	N	196	196	343	343	
Weight	Without brake	kg	Approx. 5.3	Approx. 8.3	Approx. 11.0	Approx. 14.0
	With brake	kg	Approx. 6.3	Approx. 9.4	Approx. 12.6	Approx. 16.0
Radiator plate dimensions (material)		380 x 350 x t30 (Al)				
Applicable Servo Drives (R88D-)		KP20H	KP30H	KP50H	KP50H	

● Brake Specifications

Item	Model (R88M-)	Unit	200 VAC			
			KE2K030H	KE3K030H	KE4K030H	KE5K030H
Brake inertia		kg·m ²	0.33 x 10 ⁻⁴	0.33 x 10 ⁻⁴	1.35 x 10 ⁻⁴	1.35 x 10 ⁻⁴
Excitation voltage ^{*4}		V	24 VDC±10%			
Power consumption (at 20°C)		W	19	19	22	22
Current consumption (at 20°C)		A	0.81±10%	0.81±10%	0.90±10%	0.90±10%
Static friction torque		N·m	7.8 min.	11.8 min.	16.1 min.	16.1 min.
Attraction time ^{*5}		ms	50 max.	80 max.	110 max.	110 max.
Release time ^{*5}		ms	15 max. ^{*6}	15 max. ^{*6}	50 max. ^{*7}	50 max. ^{*7}
Backlash			±1°			
Allowable work per braking		J	392	392	1,470	1,470
Allowable total work		J	4.9 x 10 ⁶	4.9 x 10 ⁶	2.2 x 10 ⁶	2.2 x 10 ⁶
Allowable angular acceleration		rad/s ²	10,000			
Brake life		–	10 million times min.			
Rating		–	Continuous			
Insulation class		–	Class F			

*1 These are the values when the Servomotor is combined with a Servo Drive at normal temperature (20°C, 65%). The momentary maximum torque indicates the standard value.

*2 Applicable load inertia

- The operable load inertia ratio (load inertia/rotor inertia) depends on the mechanical configuration and its rigidity. For a machine with high rigidity, operation is possible even with high load inertia. Select an appropriate Servomotor and confirm that operation is possible.
- The dynamic brake is rated for short-term operation. Use it only for emergency stopping. Configure the system to stop for at least three minutes after the dynamic brake operates. Otherwise, the dynamic brake circuits may fail or the dynamic brake resistor may burn.

*3 The allowable radial and thrust loads are the values determined for a limit of 20,000 hours at normal operating temperatures.

The allowable radial loads are applied as shown in the following diagram.

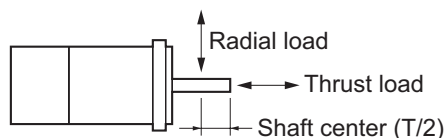

*4 This is a non-excitation brake. (It is released when excitation voltage is applied.)

*5 The operation time is the value (reference value) measured with a surge suppressor (CR50500 by Okaya Electric Industries Co., Ltd.).

*6 Direct current switching with a varistor (Z15D151 by Ishizuka Electronics Co.).

*7 Direct current switching with a varistor (TNR9G820K by Nippon Chemi-Con Corporation).

● Torque-Rotation Speed Characteristics for 3,000-r/min Servomotors

- 3,000-r/min Servomotors (200 VAC)

The following graphs show the characteristics with a 3-m global non-flexible cable and a 200-VAC input.

• R88M-KE05030H (50 W)

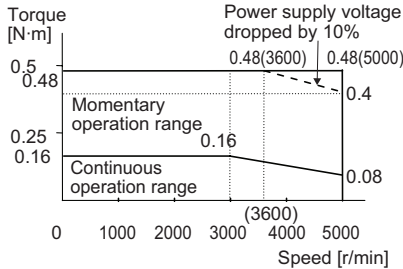

• R88M-KE10030H (100 W)

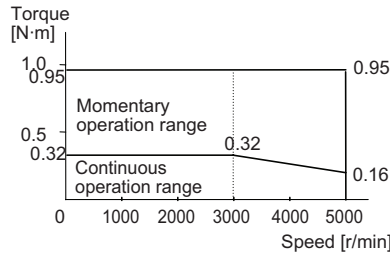

• R88M-KE20030H (200 W)

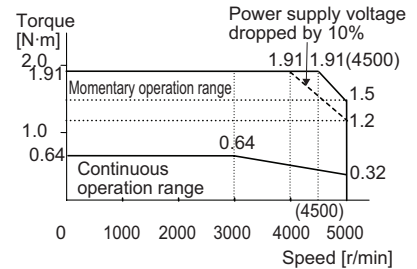

• R88M-KE40030H (400 W)

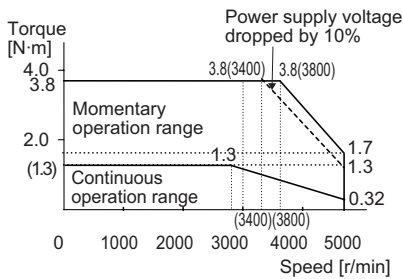

• R88M-KE75030H (750 W)

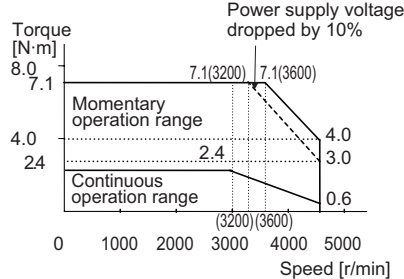

• R88M-KE1K030H (1 kW)

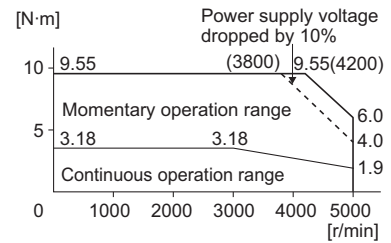

• R88M-KE1K530H (1.5 kW)

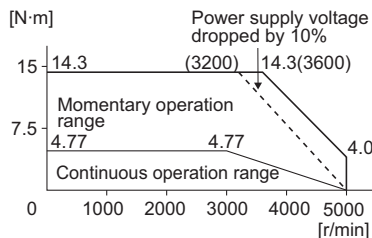

• R88M-KE2K030H (2 kW)

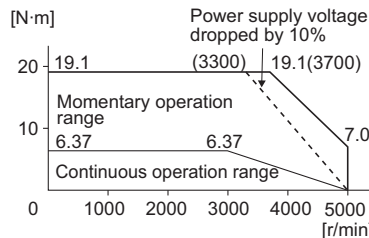

• R88M-KE3K030H (3 kW)

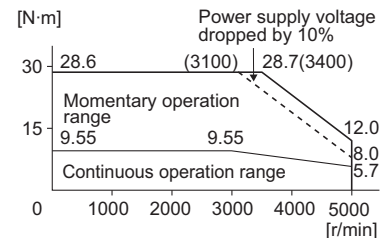

• R88M-KE4K030H (4 kW)

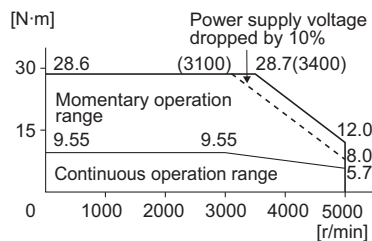

• R88M-KE5K030H (5 kW)

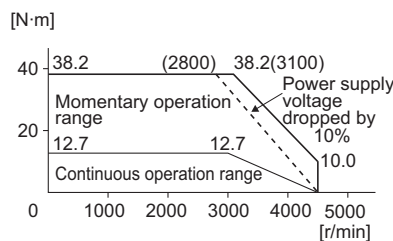

Note 1 The continuous operation range is the range in which continuous operation is possible. Continuous operation at the maximum speed is also possible. However, doing so will reduce the output torque.

2 If the motor power cable exceeds 20 m, the voltage drop will increase and the momentary operation range will become narrower.

Use the following Servomotors in the ranges shown in the graphs below. Use outside of these ranges may cause the Servomotor to generate heat, which could result in encoder malfunction.

**• R88M-KE05030H
(50 W: With oil seal)**

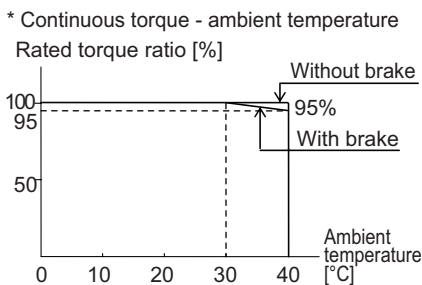

**• R88M-KE10030H
(100 W: With oil seal)**

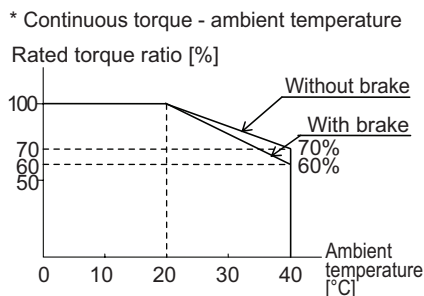

**• R88M-KE20030H
(200 W: With oil seal)**

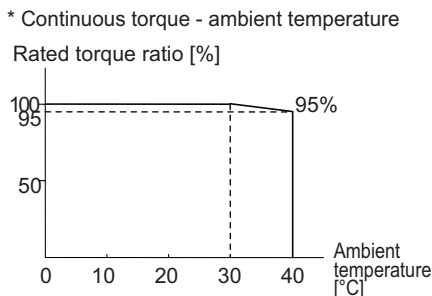

**• R88M-KE40030H
(400 W: Without oil seal)**

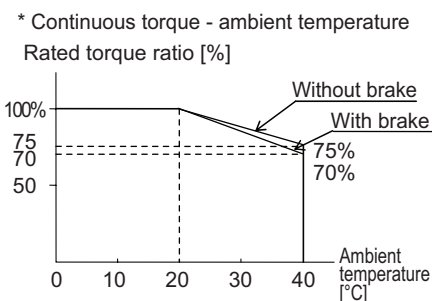

**• R88M-KE40030H
(400 W: With oil seal)**

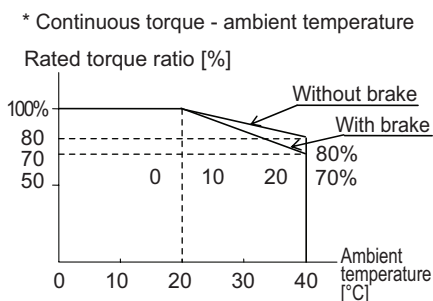

**• R88M-KE40030H
(400 W: Without oil seal)**

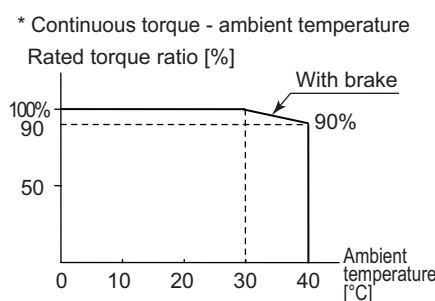

**• R88M-KE40030V1
(400 W: With oil seal)**

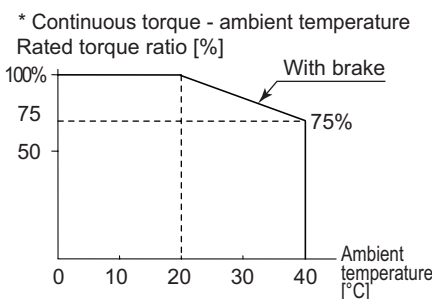

**• R88M-KE1K530H
(1.5 kW)**

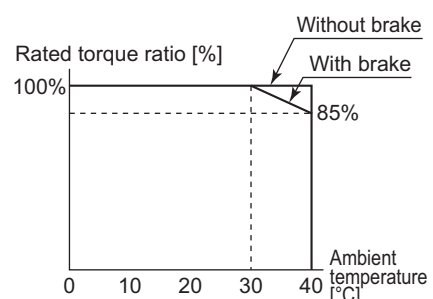

**• R88M-KE2K030H
(2 kW)**

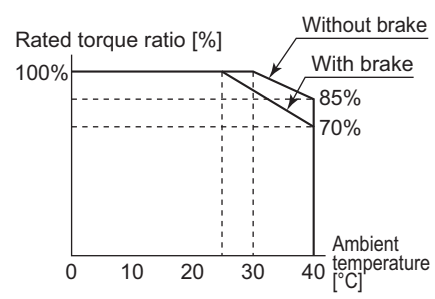

**• R88M-KE3K030H
(3 kW)**

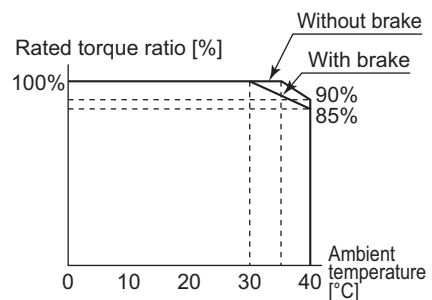

**• R88M-KE4K030H
(4 kW)**

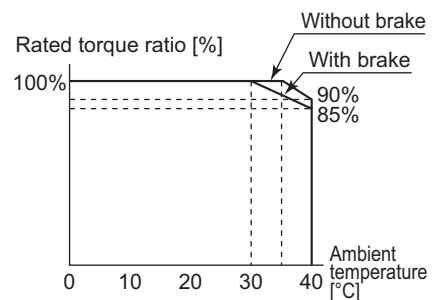

**• R88M-KE5K030H
(5 kW)**

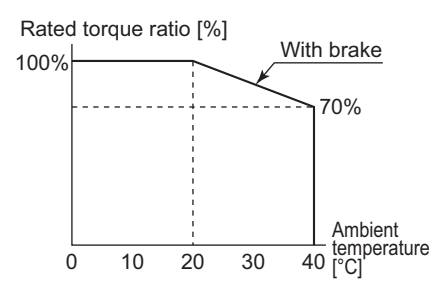

2,000-r/min Servomotors

Model (R88M-)		Unit	200 VAC		
			KE1K020H	KE1K520H	KE2K020H
Rated output ^{*1}		W	1,000	1,500	2,000
Rated torque ^{*1}		N·m	4.77	7.16	9.55
Rated rotation speed		r/min	2,000		
Maximum rotation speed		r/min	3,000		
Momentary maximum torque ^{*1}		N·m	14.3	21.5	28.6
Rated current ^{*1}		A (rms)	5.7	9.4	11.5
Momentary maximum current ^{*1}		A (rms)	24	40	49
Rotor inertia	Without brake	kg·m ²	4.60 x 10 ⁻⁴	6.70 x 10 ⁻⁴	8.72 x 10 ⁻⁴
	With brake	kg·m ²	5.90 x 10 ⁻⁴	7.99 x 10 ⁻⁴	10.0 x 10 ⁻⁴
Applicable load inertia		–	10 times the rotor inertia max. ^{*2}		
Torque constant ^{*1}		N·m/A	0.63	0.58	0.64
Power rate ^{*1}	Without brake	kW/s	49.5	76.5	105
	With brake	kW/s	38.6	64.2	91.2
Mechanical time constant	Without brake	ms	0.80	0.66	0.66
	With brake	ms	1.02	0.80	0.76
Electrical time constant		ms	9.4	10	10
Allowable radial load ^{*3}		N	490	490	490
Allowable thrust load ^{*3}		N	196	196	196
Weight	Without brake	kg	Approx. 5.2	Approx. 6.7	Approx. 8.0
	With brake	kg	Approx. 6.7	Approx. 8.2	Approx. 9.5
Radiator plate dimensions (material)			275 x 260 x t15 (Al)		
Applicable Servo Drives (R88D-)			KP10H	KP15H	KP20H

● Brake Specifications

Model (R88M-)		200 VAC		
Item	Unit	KE1K020H	KE1K520H	KE2K020H
Brake inertia	kg·m ²	1.35 x 10 ⁻⁴	1.35 x 10 ⁻⁴	1.35 x 10 ⁻⁴
Excitation voltage ^{*4}	V	24 VDC±10%		
Power consumption (at 20°C)	W	14	19	19
Current consumption (at 20°C)	A	0.59±10%	0.79±10%	0.79±10%
Static friction torque	N·m	4.9 min.	13.7 min.	13.7 min.
Attraction time ^{*5}	ms	80 max.	100 max.	100 max.
Release time ^{*5}	ms	70 max. ^{*6}	50 max. ^{*6}	50 max. ^{*6}
Backlash		±1°		
Allowable work per braking	J	588	1,176	1,176
Allowable total work	J	7.8 x 10 ⁵	1.5 x 10 ⁶	1.5 x 10 ⁶
Allowable angular acceleration	rad/s ²	10,000		
Brake life	–	10 million times min.		
Rating	–	Continuous		
Insulation class	–	Class F		

Model (R88M-)		Unit	200 VAC		
			KE3K020H	KE4K020H	KE5K020H
Rated output ^{*1}		W	3,000	4,000	5,000
Rated torque ^{*1}		N·m	14.3	19.1	23.9
Rated rotation speed		r/min	2,000		
Maximum rotation speed		r/min	3,000		
Momentary maximum torque ^{*1}		N·m	43.0	57.3	71.6
Rated current ^{*1}		A (rms)	17.4	21.0	25.9
Momentary maximum current ^{*1}		A (rms)	74	89	110
Rotor inertia	Without brake	kg·m ²	12.9 x 10 ⁻⁴	37.6 x 10 ⁻⁴	48.0 x 10 ⁻⁴
	With brake	kg·m ²	14.2 x 10 ⁻⁴	38.6 x 10 ⁻⁴	48.8 x 10 ⁻⁴
Applicable load inertia		–	10 times the rotor inertia max. ^{*2}		
Torque constant ^{*1}		N·m/A	0.59	0.70	0.70
Power rate ^{*1}	Without brake	kW/s	159	97.1	119
	With brake	kW/s	144	94.5	117
Mechanical time constant	Without brake	ms	0.57	0.65	0.63
	With brake	ms	0.63	0.66	0.64
Electrical time constant		ms	12	20	19
Allowable radial load ^{*3}		N	784	784	784
Allowable thrust load ^{*3}		N	343	343	343
Weight	Without brake	kg	Approx. 11.0	Approx. 15.5	Approx. 18.6
	With brake	kg	Approx. 12.6	Approx. 18.7	Approx. 21.8
Radiator plate dimensions (material)			380 x 350 x t30 (Al)	470 x 440 x t30 (Al)	
Applicable Servo Drives (R88D-)			KP30H	KP50H	KP50H

● Brake Specifications

Item	Model (R88M-)	Unit	200 VAC		
			KE3K020H	KE4K020H	KE5K020H
Brake inertia		kg·m ²	1.35 x 10 ⁻⁴	4.7 x 10 ⁻⁴	4.7 x 10 ⁻⁴
Excitation voltage ^{*4}		V	24 VDC±10%		
Power consumption (at 20°C)		W	22	31	31
Current consumption (at 20°C)		A	0.90±10%	1.3±10%	1.3±10%
Static friction torque		N·m	16.2 min.	24.5 min.	24.5 min.
Attraction time ^{*5}		ms	110 max.	80 max.	80 max.
Release time ^{*5}		ms	50 max. ^{*6}	25 max. ^{*7}	25 max. ^{*7}
Backlash			±1°		
Allowable work per braking		J	1,470	1,372	1,372
Allowable total work		J	2.2 x 10 ⁶	20.9 x 10 ⁶	2.9 x 10 ⁶
Allowable angular acceleration		rad/s ²	10,000		
Brake life		—	10 million times min.		
Rating		—	Continuous		
Insulation class		—	Class F		

*1 These are the values when the Servomotor is combined with a Servo Drive at normal temperature (20°C, 65%). The momentary maximum torque indicates the standard value.

*2 Applicable load inertia

- The operable load inertia ratio (load inertia/rotor inertia) depends on the mechanical configuration and its rigidity. For a machine with high rigidity, operation is possible even with high load inertia. Select an appropriate motor and confirm that operation is possible.
- The dynamic brake is rated for short-term operation. Use it only for emergency stopping. Configure the system to stop for at least three minutes after the dynamic brake operates. Otherwise, the dynamic brake circuits may fail or the dynamic brake resistor may burn.

*3 The allowable radial and thrust loads are the values determined for a limit of 20,000 hours at normal operating temperatures.

The allowable radial loads are applied as shown in the following diagram.

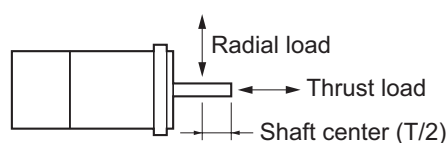

*4 This is a non-excitation brake. (It is released when excitation voltage is applied.)

*5 The operation time is the value (reference value) measured with a surge suppressor (CR50500 by Okaya Electric Industries Co., Ltd.).

*6 Direct current switching with a varistor (TNR9G820K by Nippon Chemi-Con Corporation).

*7 Direct current switching with a varistor (Z15D151 by Ishizuka Electronics Co.).

● **Torque-Rotation Speed Characteristics for 2,000-r/min Servomotors**

- 2,000-r/min Servomotors (200 VAC)

The following graphs show the characteristics with a 3-m global non-flexible cable and a 200-VAC input.

• **R88M-KE1K020H (1 kW)**

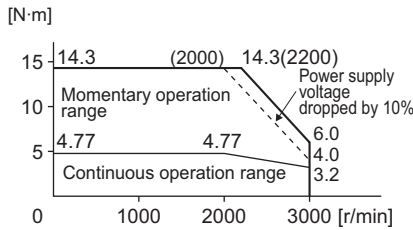

• **R88M-KE1K520H (1.5 kW)**

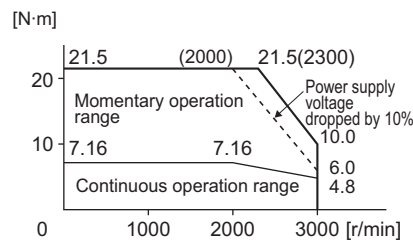

• **R88M-KE2K020H (2 kW)**

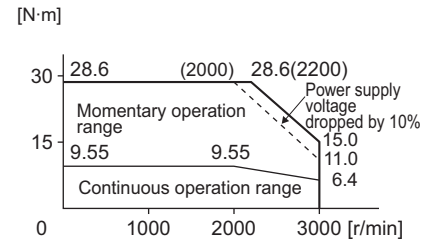

• **R88M-KE3K020H (3 kW)**

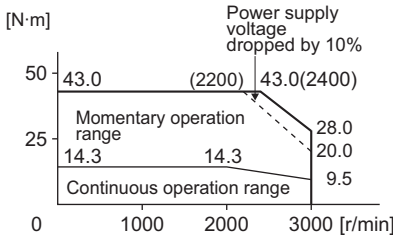

• **R88M-KE4K020H (4 kW)**

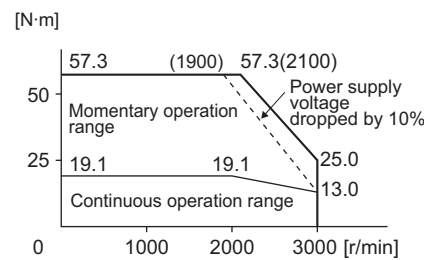

• **R88M-KE5K020H (5 kW)**

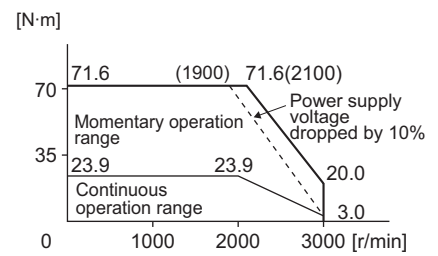

Note 1 The continuous operation range is the range in which continuous operation is possible. Continuous operation at the maximum speed is also possible. However, doing so will reduce the output torque.

- 2 If the motor power cable exceeds 20 m, the voltage drop will increase and the momentary operation range will become narrower.

Use the following Servomotors in the ranges shown in the graphs below. Use outside of these ranges may cause the Servomotor to generate heat, which could result in encoder malfunction.

• **R88M-KE5K020H (5 kW)**

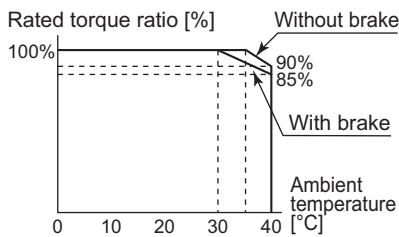

1,000-r/min Servomotors

Model (R88M-)		Unit	200 VAC		
			KE90010H	KE2K010H	KE3K010H
Rated output ^{*1}		W	900	2,000	3,000
Rated torque ^{*1}		N·m	8.59	19.1	28.7
Rated rotation speed		r/min	1,000		
Maximum rotation speed		r/min	2,000		
Momentary maximum torque ^{*1}		N·m	19.3	47.7	71.7
Rated current ^{*1}		A (rms)	7.6	17.0	22.6
Momentary maximum current ^{*1}		A (rms)	24	60	80
Rotor inertia	Without brake	kg·m ²	6.70 x 10 ⁻⁴	30.3 x 10 ⁻⁴	48.4 x 10 ⁻⁴
	With brake	kg·m ²	7.99 x 10 ⁻⁴	31.4 x 10 ⁻⁴	49.2 x 10 ⁻⁴
Applicable load inertia		—	10 times the rotor inertia max. ^{*2}		
Torque constant ^{*1}		N·m/A	0.86	0.88	0.96
Power rate ^{*1}	Without brake	kW/s	110	120	170
	With brake	kW/s	92.4	116	167
Mechanical time constant	Without brake	ms	0.66	0.75	0.63
	With brake	ms	0.78	0.78	0.64
Electrical time constant		ms	11	18	21
Allowable radial load ^{*3}		N	686	1,176	1,470
Allowable thrust load ^{*3}		N	196	490	490
Weight	Without brake	kg	Approx. 6.7	Approx. 14.0	Approx. 20.0
	With brake	kg	Approx. 8.2	Approx. 17.5	Approx. 23.5
Radiator plate dimensions (material)			270 x 260 x t15 (Al)		
Applicable Servo Drives (R88D-)			KP15H	KP30H	KP50H

● Brake Specifications

Model (R88M-)		200 VAC		
Item	Unit	KE90010H	KE2K010H	KE3K010H
Brake inertia	kg·m ²	1.35 x 10 ⁻⁴	4.7 x 10 ⁻⁴	4.7 x 10 ⁻⁴
Excitation voltage* ⁴	V	24 VDC±10%		
Power consumption (at 20°C)	W	19	31	34
Current consumption (at 20°C)	A	0.79±10%	1.3±10%	1.4±10%
Static friction torque	N·m	13.7 min.	24.5 min.	58.8 min.
Attraction time* ⁵	ms	100 max.	80 max.	150 max.
Release time* ⁵	ms	50 max.* ⁶	25 max.* ⁷	50 max.* ⁷
Backlash		±1°		
Allowable work per braking	J	1176	1372	1372
Allowable total work	J	1.5 x 10 ⁶	20.9 x 10 ⁶	2.9 x 10 ⁶
Allowable angular acceleration	rad/s ²	10,000		
Brake life	–	10 million times min.		
Rating	–	Continuous		
Insulation class	–	Class F		

*1 These are the values when the Servomotor is combined with a Servo Drive at normal temperature (20°C, 65%). The momentary maximum torque indicates the standard value.

*2 Applicable load inertia

- The operable load inertia ratio (load inertia/rotor inertia) depends on the mechanical configuration and its rigidity. For a machine with high rigidity, operation is possible even with high load inertia. Select an appropriate Servomotor and confirm that operation is possible.
- The dynamic brake is rated for short-term operation. Use it only for emergency stopping. Configure the system to stop for at least three minutes after the dynamic brake operates. Otherwise, the dynamic brake circuits may fail or the dynamic brake resistor may burn.

*3 The allowable radial and thrust loads are the values determined for a limit of 20,000 hours at normal operating temperatures.

The allowable radial loads are applied as shown in the following diagram.

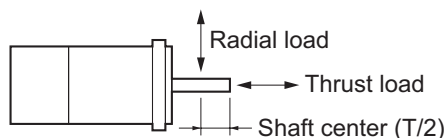

*4 This is a non-excitation brake. (It is released when excitation voltage is applied.)

*5 The operation time is the value (reference value) measured with a surge suppressor (CR50500 by Okaya Electric Industries Co., Ltd.).

*6 Direct current switching with a varistor (TNR9G820K by Nippon Chemi-Con Corporation).

*7 Direct current switching with a varistor (Z15D151 by Ishizuka Electronics Co.).

● Torque-Rotation Speed Characteristics for 1,000-r/min Servomotors

- 1,000-r/min Servomotors (200 VAC)

The following graphs show the characteristics with a 3-m global non-flexible cable and a 200-VAC input.

• R88M-KE90010H (900 W)

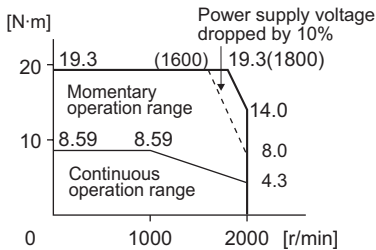

• R88M-KE2K010H (2 kW)

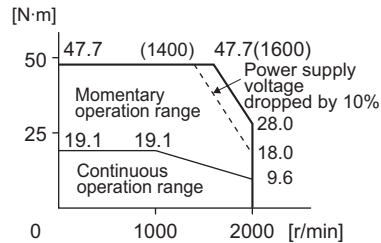

• R88M-KE3K010H (3 kW)

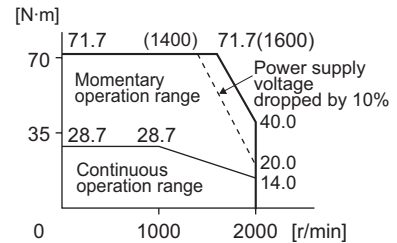

- Note 1** The continuous operation range is the range in which continuous operation is possible. Continuous operation at the maximum speed is also possible. However, doing so will reduce the output torque.
- Note 2** If the motor power cable exceeds 20 m, the voltage drop will increase and the momentary operation range will become narrower.

Temperature Characteristics of the Motor and Mechanical System

- G5-series AC Servomotors (Pulse-train Input Type) use rare earth magnets (neodymium-iron magnets).
The temperature coefficient for these magnets is approximately $-0.13\%/^{\circ}\text{C}$. As the temperature drops, the motor's momentary maximum torque increases, and as the temperature rises, the motor's momentary maximum torque decreases.
- The momentary maximum torque rises by approximately 4% at a normal temperature of 20°C compared to a temperature of -10°C .
Conversely, the momentary maximum torque decreases approximately 8% when the magnet warms up to 80°C from the normal temperature.
- Generally, when the temperature drops in a mechanical system, the friction torque and the load torque increase.
For that reason, overloading may occur at low temperatures. In particular, in systems that use a Decelerator, the load torque at low temperatures may be nearly twice as much as the load torque at normal temperatures.
Check whether overloading may occur when starting at low temperatures.
Also check to see whether abnormal motor overheating or errors occur at high temperatures.
- An increase in load friction torque seemingly increases load inertia.
Therefore, even if the Servo Drive gains are adjusted at a normal temperature, the Servomotor may not operate properly at low temperatures.
Check to see whether optimal operation can be obtained even at low temperatures.

3-3-3 Encoder Specifications

Incremental Encoder Specifications

Item	Specifications
Encoder system	Optical encoder 20 bits
Number of output pulses	Phases A and B: 262,144 pulses/rotation Phase Z: 1 pulse/rotation
Power supply voltage	5 VDC±5%
Power supply current	180 mA (max.)
Output signal	+S, -S
Output interface	RS485 compliant

3-4 Decelerator Specifications

The following tables list the Decelerator models for OMNUC G5-series Servomotors. Select an appropriate model based on the Servomotor capacity.

3-4-1 Models and Specifications

Backlash: 3 Arcminutes max.

● For 3,000-r/min Servomotors

Model			Rated rotation speed	Rated torque	Efficiency	Momentary maximum rotation speed	Momentary maximum torque	Decelerator inertia	Allowable radial load	Allowable thrust load	Weight
			r/min	N·m	%	r/min	N·m	kg·m ²	N	N	kg
50 W	1/5	R88G-HPG11B05100B□	600	0.50	63	1,200	1.51	5.00 x 10 ⁻⁷	135	538	0.3
	1/9	R88G-HPG11B09050B□	333	1.12	78	666	3.37	3.00 x 10 ⁻⁷	161	642	0.3
	1/21	R88G-HPG14A21100B□	143	2.18	65	286	6.55	5.00 x 10 ⁻⁶	340	1,358	1.0
	1/33	R88G-HPG14A33050B□	91	3.75	71	182	11.2	4.40 x 10 ⁻⁶	389	1,555	1.0
	1/45	R88G-HPG14A45050B□	67	5.11	71	134	15.3	4.40 x 10 ⁻⁶	427	1,707	1.0
100 W	1/5	R88G-HPG11B05100B□	600	1.28	80	1,200	3.80	5.00 x 10 ⁻⁷	135	538	0.3
	1/11	R88G-HPG14A11100B□	273	2.64	75	546	7.84	6.00 x 10 ⁻⁶	280	1,119	1.0
	1/21	R88G-HPG14A21100B□	143	5.38	80	286	16.0	5.00 x 10 ⁻⁶	340	1,358	1.0
	1/33	R88G-HPG20A33100B□	91	6.86	65	182	20.4	6.50 x 10 ⁻⁶	916	3,226	2.4
	1/45	R88G-HPG20A45100B□	67	9.36	65	134	27.8	6.50 x 10 ⁻⁶	1,006	3,541	2.4
200 W	1/5	R88G-HPG14A05200B□	600	2.50	78	1,200	7.45	2.07 x 10 ⁻⁵	221	883	1.0
	1/11	R88G-HPG14A11200B□	273	5.98	85	546	17.9	1.93 x 10 ⁻⁵	280	1,119	1.1
	1/21	R88G-HPG20A21200B□	143	10.2	76	286	30.5	4.90 x 10 ⁻⁵	800	2,817	2.9
	1/33	R88G-HPG20A33200B□	91	17.1	81	182	51.1	4.50 x 10 ⁻⁵	916	3,226	2.9
	1/45	R88G-HPG20A45200B□	67	23.3	81	134	69.6	4.50 x 10 ⁻⁵	1,006	3,541	2.9

Model			Rated rotation speed	Rated torque	Efficiency	Momentary maximum rotation speed	Momentary maximum torque	Decelerator inertia	Allowable radial load	Allowable thrust load	Weight
			r/min	N·m	%	r/min	N·m	kg·m ²	N	N	kg
400 W	1/5	R88G-HPG14A05400B□	600	5.66	87	1,200	16.5	2.07 x 10 ⁻⁵	221	883	1.1
	1/11	R88G-HPG20A11400B□	273	11.7	82	546	34.3	5.67 x 10 ⁻⁵	659	2,320	2.9
	1/21	R88G-HPG20A21400B□	143	23.5	86	286	68.6	4.90 x 10 ⁻⁵	800	2,547	2.9
	1/33	R88G-HPG32A33400B□	91	34.7	81	182	101.6	6.20 x 10 ⁻⁵	1,565	6,240	7.5
	1/45	R88G-HPG32A45400B□	67	47.4	81	134	138.5	6.10 x 10 ⁻⁵	1,718	6,848	7.5
750 W	1/5	R88G-HPG20A05750B□	600	9.96	83	1,000	29.5	6.80 x 10 ⁻⁵	520	1,832	2.9
	1/11	R88G-HPG20A11750B□	273	20.0 ^{*1}	88	455	68.7	6.00 x 10 ⁻⁵	659	2,320	3.1
	1/21	R88G-HPG32A21750B□	143	42.3	84	238	125.2	3.00 x 10 ⁻⁴	1,367	5,448	7.8
	1/33	R88G-HPG32A33750B□	91	69.7	88	152	206.2	2.70 x 10 ⁻⁴	1,565	6,240	7.8
	1/45	R88G-HPG32A45750B□	67	95.0	88	112	281.2	2.70 x 10 ⁻⁴	1,718	6,848	7.8
1 kW	1/5	R88G-HPG32A052K0B□	600	11.4	72	1,000	34.4	3.90 x 10 ⁻⁴	889	3,542	7.4
	1/11	R88G-HPG32A112K0B□	273	29.0	83	454	87.2	3.40 x 10 ⁻⁴	1,126	4,488	7.9
	1/21	R88G-HPG32A211K5B□	143	58.1	87	238	174.5	3.00 x 10 ⁻⁴	1,367	5,448	7.9
	1/33	R88G-HPG50A332K0B□	91	91.3	87	151	274.2	4.80 x 10 ⁻⁴	4,135	14,300	19.0
	1/45	R88G-HPG50A451K5B□	67	124.5	87	100 ^{*2}	373.9	4.70 x 10 ⁻⁴	4,538	15,694	19.0

Model			Rated rotation speed	Rated torque	Efficiency	Momentary maximum rotation speed	Momentary maximum torque	Decelerator inertia	Allowable radial load	Allowable thrust load	Weight
			r/min	N·m	%	r/min	N·m	kg·m ²	N	N	kg
1.5 kW	1/5	R88G-HPG32A052K0B□	600	19.1	80	1,000	57.2	3.90 x 10 ⁻⁴	889	3,542	7.4
	1/11	R88G-HPG32A112K0B□	273	45.6	87	454	136.9	3.40 x 10 ⁻⁴	1,126	4,488	7.9
	1/21	R88G-HPG32A211K5B□	143	90.2	90	238	270.3	3.00 x 10 ⁻⁴	1,367	5,448	7.9
	1/33	R88G-HPG50A332K0B□	91	141.7	90	136	424.7	4.80 x 10 ⁻⁴	4,135	14,300	19.0
	1/45	R88G-HPG50A451K5B□	67	193.2	90	100 ^{*2}	579.2	4.70 x 10 ⁻⁴	4,538	15,694	19.0
2 kW	1/5	R88G-HPG32A052K0B□	600	26.8	84	1,000	80.2	3.90 x 10 ⁻⁴	889	3,542	7.4
	1/11	R88G-HPG32A112K0B□	273	62.4	89	454	187.0	3.40 x 10 ⁻⁴	1,126	4,488	7.9
	1/21	R88G-HPG50A212K0B□	143	119.1	89	214 ^{*2}	357.0	5.80 x 10 ⁻⁴	3,611	12,486	19.0
	1/33	R88G-HPG50A332K0B□	91	191.3	91	136 ^{*2}	573.6	4.80 x 10 ⁻⁴	4,135	14,300	19.0
3 kW	1/5	R88G-HPG32A053K0B□	600	42.0	88	1,000	125.8	3.80 x 10 ⁻⁴	889	3,542	7.3
	1/11	R88G-HPG50A113K0B□	273	92.4	88	409 ^{*2}	276.8	7.70 x 10 ⁻⁴	2,974	10,285	19.0
	1/21	R88G-HPG50A213K0B□	143	182.5	91	214 ^{*2}	546.5	5.80 x 10 ⁻⁴	3,611	12,486	19.0
4 kW	1/5	R88G-HPG32A054K0B□	600	54.6	86	900 ^{*2}	164.3	3.80 x 10 ⁻⁴	889	3,542	7.9
	1/11	R88G-HPG50A115K0B□	273	125.7	90	409 ^{*2}	378.2	8.80 x 10 ⁻⁴	2,974	10,285	19.1
5 kW	1/5	R88G-HPG50A055K0B□	600	70.0	88	900 ^{*2}	209.9	1.20 x 10 ⁻³	2,347	8,118	18.6
	1/11	R88G-HPG50A115K0B□	273	159.2	91	409 ^{*2}	477.5	8.80 x 10 ⁻⁴	2,974	10,285	19.1

*1 The value is the allowable continuous output torque of the Decelerator. Do not exceed this value.

*2 The value is the maximum allowable rotation speed of the Decelerator. Do not exceed the maximum motor shaft rotation speed of 4,500 r/min.

Note 1 The Decelerator inertia is the Servomotor shaft conversion value.

2 The protective structure rating of the Servomotor with the Decelerator is IP44.

3 The Allowable radial load column shows the values obtained at the center of the shaft (T/2).

4 The standard shaft type is a straight shaft. A model with a key and tap is indicated with J at the end of the model number (the suffix shown in the box).

● For 2,000-r/min Servomotors

Model			Rated rotation speed	Rated torque	Efficiency	Momentary maximum rotation speed	Momentary maximum torque	Decelerator inertia	Allowable radial load	Allowable thrust load	Weight
			r/min	N·m	%	r/min	N·m	kg·m ²	N	N	kg
1 kW	1/5	R88G-HPG32A053K0B□	400	20.3	85	600	60.8	3.90 x 10 ⁻⁴	889	3,542	7.3
	1/11	R88G-HPG32A112K0SB□	182	47.2	90	273	141.6	3.40 x 10 ⁻⁴	1,126	4,488	7.8
	1/21	R88G-HPG32A211K0SB□	95	92.2	92	143	276.3	2.90 x 10 ⁻⁴	1,367	5,448	7.8
	1/33	R88G-HPG50A332K0SB□	60	144.8	92	91	434.1	4.70 x 10 ⁻⁴	4,135	14,300	19.0
	1/45	R88G-HPG50A451K0SB□	44	197.5	92	67	592.2	4.70 x 10 ⁻⁴	4,538	15,694	19.0
1.5 kW	1/5	R88G-HPG32A053K0B□	400	31.8	89	600	95.7	3.80 x 10 ⁻⁴	889	3,542	7.3
	1/11	R88G-HPG32A112K0SB□	182	72.5	92	273	217.6	3.40 x 10 ⁻⁴	1,126	4,488	7.8
	1/21	R88G-HPG50A213K0B□	95	138.3	92	143	415.4	5.80 x 10 ⁻⁴	3,611	12,486	19.0
	1/33	R88G-HPG50A332K0SB□	60	219.7	93	91	659.8	4.70 x 10 ⁻⁴	4,135	14,300	19.0

Model			Rated rotation speed	Rated torque	Efficiency	Momentary maximum rotation speed	Momentary maximum torque	Decelerator inertia	Allowable radial load	Allowable thrust load	Weight
			r/min	N·m	%	r/min	N·m	kg·m ²	N	N	kg
2 kW	1/5	R88G-HPG32A053K0B□	400	43.5	91	600	130.6	3.80 x 10 ⁻⁴	889	3,542	7.3
	1/11	R88G-HPG32A112K0SB□	182	97.7	93	273	293.6	3.40 x 10 ⁻⁴	1,126	4,488	7.8
	1/21	R88G-HPG50A213K0B□	95	186.5	93	143	560.5	5.80 x 10 ⁻⁴	3,611	12,486	19.0
	1/33	R88G-HPG50A332K0SB□	60	270.0 ^{*1}	93	91	850.0 ^{*3}	4.70 x 10 ⁻⁴	4,135	14,300	19.0
3 kW	1/5	R88G-HPG32A054K0B□	400	64.4	90	600	197.8	3.80 x 10 ⁻⁴	889	3,542	7.9
	1/11	R88G-HPG50A115K0B□	182	144.7	92	273	435.2	8.80 x 10 ⁻⁴	2,974	10,285	19.1
	1/21	R88G-HPG50A213K0SB□	95	260.0 ^{*1}	93	143	839.8	6.90 x 10 ⁻⁴	3,611	12,486	19.1
	1/25	R88G-HPG65A253K0SB□	80	321.8	90	120	967.5	3.00 x 10 ⁻³	7,846	28,654	52.0
4 kW	1/5	R88G-HPG50A055K0SB□	400	86.9	91	600	260.7	1.10 x 10 ⁻³	2,347	8,118	22.0
	1/11	R88G-HPG50A115K0SB□	182	195.4	93	273	586.2	8.40 x 10 ⁻⁴	2,974	10,285	23.5
	1/20	R88G-HPG65A205K0SB□	100	347.6	91	150	1042.9	2.85 x 10 ⁻³	7,338	26,799	55.4
	1/25	R88G-HPG65A255K0SB□	80	439.3	92	120	1317.9	2.81 x 10 ⁻³	7,846	28,654	55.4
5 kW	1/5	R88G-HPG50A055K0SB□	400	109.9	92	600	329.4	1.10 x 10 ⁻³	2,347	8,118	22.0
	1/11	R88G-HPG50A115K0SB□	182	200.0 ^{*1}	93	273	732.5	8.40 x 10 ⁻⁴	2,974	10,285	23.5
	1/20	R88G-HPG65A205K0SB□	100	439.7	92	150	1317.4	2.85 x 10 ⁻³	7,338	26,799	55.4
	1/25	R88G-HPG65A255K0SB□	80	555.7	93	120	1664.7	2.81 x 10 ⁻³	7,846	28,654	55.4

*1 The value is the allowable continuous output torque of the Decelerator. Do not exceed this value.

*2 The value is the maximum allowable rotation speed of the Decelerator. Do not exceed the maximum motor shaft rotation speed of 4,500 r/min.

*3 The value is the maximum allowable torque of the Decelerator. Do not exceed this value.

Note 1 The Decelerator inertia is the Servomotor shaft conversion value.

2 The protective structure rating of the Servomotor with the Decelerator is IP44.

3 The Allowable radial load column shows the values obtained at the center of the shaft (T/2).

4 The standard models have a straight shaft. A model with a key and tap is indicated with J at the end of the model number (the suffix shown in the box).

● For 1,000-r/min Servomotors

Model			Rated rotation speed	Rated torque	Efficiency	Momentary maximum rotation speed	Momentary maximum torque	Decelerator inertia	Allowable radial load	Allowable thrust load	Weight
			r/min	N·m	%	r/min	N·m	kg·m ²	N	N	kg
900 W	1/5	R88G-HPG32A05900TB□	200	39.9	93	400	89.7	3.80 x 10 ⁻⁴	889	3,542	7.9
	1/11	R88G-HPG32A11900TB□	90	88.8	94	182	199.6	3.40 x 10 ⁻⁴	1,126	4,488	8.4
	1/21	R88G-HPG50A21900TB□	47	169.6	94	95	381.0	7.00 x 10 ⁻⁴	3,611	12,486	19.1
	1/33	R88G-HPG50A33900TB□	30	266.5	94	60	598.7	5.90 x 10 ⁻⁴	4,135	14,300	19.1
2 kW	1/5	R88G-HPG32A052K0TB□	200	90.7	95	400	226.6	4.90 x 10 ⁻⁴	889	3,542	8.90
	1/11	R88G-HPG50A112K0TB□	90	197.5	94	182	493.2	8.40 x 10 ⁻⁴	2,974	10,285	20.1
	1/21	R88G-HPG50A212K0TB□	47	260.0 ^{*1}	95	95	850.0 ^{*1}	6.50 x 10 ⁻³	3,611	12,486	20.1
	1/25	R88G-HPG65A255K0SB□	40	448.9	94	80	1121.0	2.81 x 10 ⁻³	7,846	28,654	55.4
3 kW	1/5	R88G-HPG50A055K0SB□	200	134.9	94	400	337.0	1.10 x 10 ⁻³	2,347	8,118	22.0
	1/11	R88G-HPG50A115K0SB□	90	246.0 ^{*1}	95	182	749.3	8.40 x 10 ⁻⁴	2,974	10,285	23.5
	1/20	R88G-HPG65A205K0SB□	50	539.6	94	100	1348.0	2.85 x 10 ⁻³	7,338	26,799	55.4
	1/25	R88G-HPG65A255K0SB□	40	674.5	94	80	1684.9	2.81 x 10 ⁻³	7,846	28,654	55.4

*1 The value is the allowable continuous output torque of the Decelerator. Do not exceed this value.

Note 1 The Decelerator inertia is the Servomotor shaft conversion value.

2 The protective structure rating of the Servomotor with the Decelerator is IP44.

3 The Allowable radial load column shows the values obtained at the center of the shaft (T/2).

4 The standard models have a straight shaft. A model with a key and tap is indicated with J at the end of the model number (the suffix shown in the box).

Backlash: 15 Arcminutes max.

● For 3,000-r/min Servomotors

Model			Rated rotation speed	Rated torque	Efficiency	Momentary maximum rotation speed	Momentary maximum torque	Decelerator inertia	Allowable radial load	Allowable thrust load	Weight
			r/min	N·m	%	r/min	N·m	kg·m ²	N	N	kg
50 W	1/5	R88G-VRSF05B100CJ	600	0.52	65	1,000	1.56	4.00 x 10 ⁻⁶	392	196	0.55
	1/9	R88G-VRSF09B100CJ	333	0.94	65	556	2.81	3.50 x 10 ⁻⁶	441	220	0.55
	1/15	R88G-VRSF15B100CJ	200	1.68	70	333	5.04	3.50 x 10 ⁻⁶	588	294	0.70
	1/25	R88G-VRSF25B100CJ	120	2.80	70	200	8.40	3.25 x 10 ⁻⁶	686	343	0.70
100 W	1/5	R88G-VRSF05B100CJ	600	1.20	75	1,000	3.56	4.00 x 10 ⁻⁶	392	196	0.55
	1/9	R88G-VRSF09B100CJ	333	2.30	80	556	6.84	3.50 x 10 ⁻⁶	441	220	0.55
	1/15	R88G-VRSF15B100CJ	200	3.84	80	333	11.4	3.50 x 10 ⁻⁶	588	294	0.70
	1/25	R88G-VRSF25B100CJ	120	6.40	80	200	19.0	3.25 x 10 ⁻⁶	686	343	0.70
200 W	1/5	R88G-VRSF05B200CJ	600	2.72	85	1,000	8.12	1.18 x 10 ⁻⁵	392	196	0.72
	1/9	R88G-VRSF09C200CJ	333	3.80	66	556	11.3	2.75 x 10 ⁻⁵	931	465	1.70
	1/15	R88G-VRSF15C200CJ	200	6.34	66	333	18.9	3.00 x 10 ⁻⁵	1,176	588	2.10
	1/25	R88G-VRSF25C200CJ	120	11.2	70	200	33.4	2.88 x 10 ⁻⁵	1,323	661	2.10

Model			Rated rotation speed	Rated torque	Efficiency	Momentary maximum rotation speed	Momentary maximum torque	Decelerator inertia	Allowable radial load	Allowable thrust load	Weight
			r/min	N·m	%	r/min	N·m	kg·m ²	N	N	kg
400 W	1/5	R88G-VRSF05C400CJ	600	5.40	85	1,000	15.6	3.63×10^{-5}	784	392	1.70
	1/9	R88G-VRSF09C400CJ	333	9.50	83	556	27.4	2.75×10^{-5}	931	465	1.70
	1/15	R88G-VRSF15C400CJ	200	15.8	83	333	45.7	3.00×10^{-5}	1,176	588	2.10
	1/25	R88G-VRSF25C400CJ	120	26.4	83	200	76.1	2.88×10^{-5}	1,323	661	2.10
750 W	1/5	R88G-VRSF05C750CJ	600	10.7	90	1,000	31.7	7.13×10^{-5}	784	392	2.10
	1/9	R88G-VRSF09D750CJ	333	18.2	85	556	53.9	6.50×10^{-5}	1,176	588	3.40
	1/15	R88G-VRSF15D750CJ	200	30.4	85	333	89.9	7.00×10^{-5}	1,372	686	3.80
	1/25	R88G-VRSF25D750CJ	120	50.7	85	200	149.8	6.80×10^{-5}	1,617	808	3.80

Note 1 The Decelerator inertia is the Servomotor shaft conversion value.

2 The protective structure rating of the Servomotor with the Decelerator is IP44.

3 The Allowable radial load column shows the values obtained at the center of the shaft (T/2).

4 The standard shaft type is a shaft with key.

5 The allowable input rotation speed of the Decelerator is 5,000 r/min.
Do not exceed the limit.

3-5 Cable and Connector Specifications

The specifications of the cables that connect the Servo Drive with a Servomotor are shown below. The information on the connectors is also provided.

Select an appropriate cable for the Servomotor.

3-5-1 Resistance to Bending of Global Flexible Cable

If the cable is used in a moving environment, use a global flexible cable.

Regarding the bending life of a global flexible cable, a wire rod with a durability of more than 20 million times of use at or above the minimum bending radius is used under the conditions below.



Precautions for Correct Use

- Because the life expectancy data on resistance to bending is intended for reference only, use the cable with a sufficient margin.
- The durability of more than 20 million times of use refers to the number of times which the core conductor provides electrical continuity without causing cracks and scratches that can have functional impact on the sheath, which does not cover the disconnection of shielded wire.
- Malfunction or grounding fault due to dielectric breakdown may occur if cables are used at a radius smaller than the minimum bending radius.

Moving Bend Test

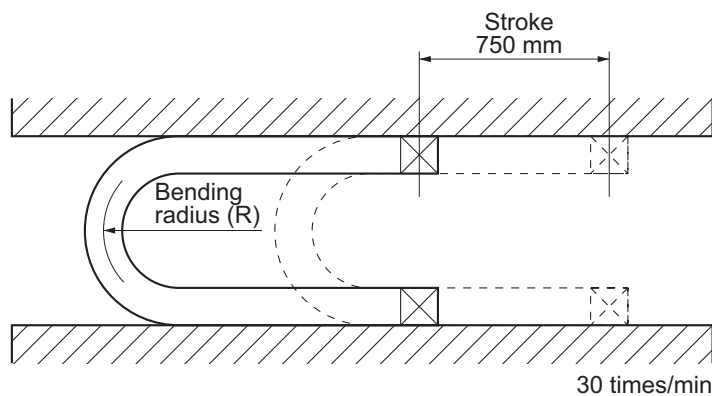

Encoder Cables

Model	Minimum bending radius (R)
R88A-CRGB□□□CR ^{*1}	45 mm
R88A-CRGC□□□NR ^{*1}	45 mm

*1 □□□ represents a number between 003 and 020.

Power Cables without Brake

Model	Minimum bending radius (R)
R88A-CAGA□□□SR ^{*1}	45 mm
R88A-CAGB□□□SR ^{*1}	90 mm
R88A-CAGD□□□SR ^{*1}	100 mm

*1 □□□ represents a number between 003 and 020.

Power Cables with Brake

Model	Cable type	Minimum bending radius (R)
R88A-CAGB□□□BR ^{*1}	Power cable	90 mm
	Brake cable	45 mm
R88A-CAGD□□□BR ^{*1}	Power cable	100 mm
	Brake cable	45 mm

*1 □□□ represents a number between 003 and 020.

Brake cable

Model	Minimum bending radius (R)
R88A-CAGA□□□BR ^{*1}	45 mm

*1 □□□ represents a number between 003 and 020.

3-5-2 Encoder Cable Specifications

These cables are used to connect an encoder between the Servo Drive and Servomotor. Select an appropriate cable for the Servomotor.

Encoder Cables: Global Non-Flexible Cable (R88A-CRGB□C)

- **Cable types**
(Incremental encoders: For 3,000-r/min Servomotors of 50 to 750 W)

Model	Length (L)	Outer diameter of sheath	Weight
R88A-CRGB003C	3 m	6.5 dia.	Approx. 0.2 kg
R88A-CRGB005C	5 m		Approx. 0.3 kg
R88A-CRGB010C	10 m		Approx. 0.6 kg
R88A-CRGB015C	15 m		Approx. 0.9 kg
R88A-CRGB020C	20 m		Approx. 1.2 kg

- **Connection configuration and external dimensions**

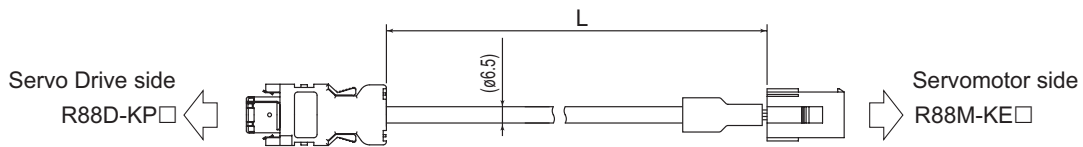

- **Wiring**

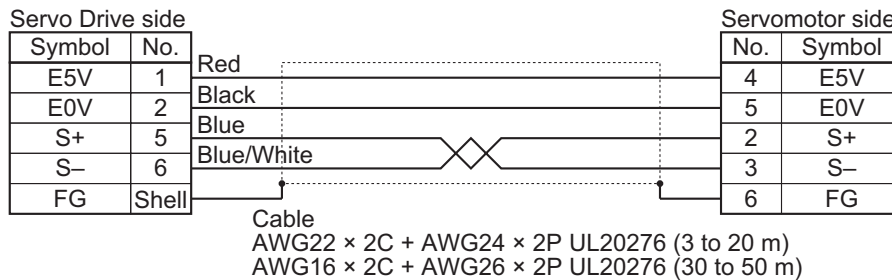

[Servo Drive side connector]

Connector model

3 to 20 m: Crimp-type I/O connector (Molex Japan)

30 to 50 m: 55100-0670 (Molex Japan)

Connector pin model

50639-8028 (Molex Japan)

[Servomotor side connector]

Connector model

172160-1 (Tyco Electronics AMP KK)

Connector pin model

170365-1 (Tyco Electronics AMP KK)

171639-1 (Tyco Electronics AMP KK)

For AWG16

Encoder Cables: Global Non-Flexible Cable (R88A-CRGC□N)

- **Cable types**
(Incremental encoders: For 3,000-r/min Servomotors of 1 to 5 kW, 2,000-r/min Servomotors of 1 to 5 kW, and 1,000-r/min Servomotors of 900 W to 3 kW)

Model	Length (L)	Outer diameter of sheath	Weight
R88A-CRGC003N	3 m	6.5 dia.	Approx. 0.3 kg
R88A-CRGC005N	5 m		Approx. 0.4 kg
R88A-CRGC010N	10 m		Approx. 0.7 kg
R88A-CRGC015N	15 m		Approx. 1.0 kg
R88A-CRGC020N	20 m		Approx. 1.5 kg

- **Connection configuration and external dimensions**

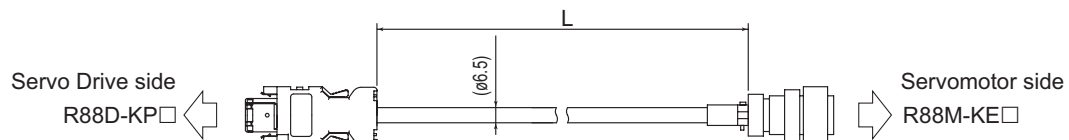

- **Wiring**

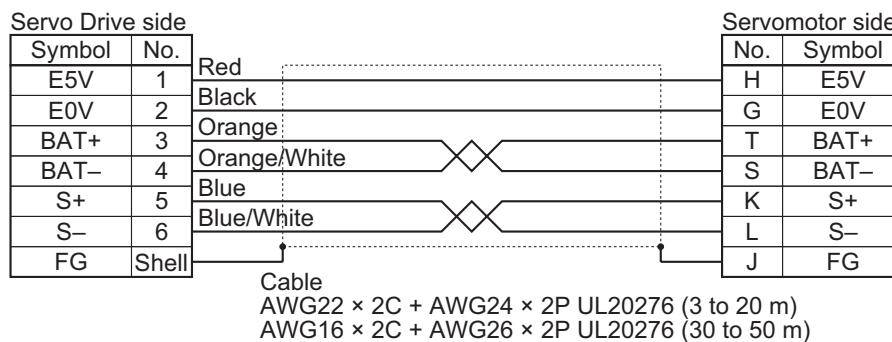

[Servo Drive side connector]

Connector model

3 to 20 m: Crimp-type I/O connector (Molex Japan)

30 to 50 m: 55100-0670 (Molex Japan)

Connector pin model

50639-8028 (Molex Japan)

[Servomotor side connector]

Straight plug model

N/MS3106B20-29S

(Japan Aviation Electronics)

Cable clamp model

N/MS3057-12A

(Japan Aviation Electronics)

Encoder Cables: Global Flexible Cable (R88A-CRGB□CR)

- **Cable types**
(Incremental encoders: For 3,000-r/min Servomotors of 50 to 750 W)

Model	Length (L)	Outer diameter of sheath	Weight
R88A-CRGB003CR	3 m	7.5 dia.	Approx. 0.2 kg
R88A-CRGB005CR	5 m		Approx. 0.4 kg
R88A-CRGB010CR	10 m		Approx. 0.8 kg
R88A-CRGB015CR	15 m		Approx. 1.1 kg
R88A-CRGB020CR	20 m		Approx. 1.5 kg

- **Connection configuration and external dimensions**

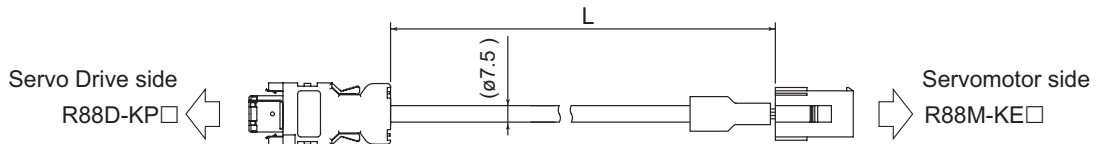

- **Wiring**

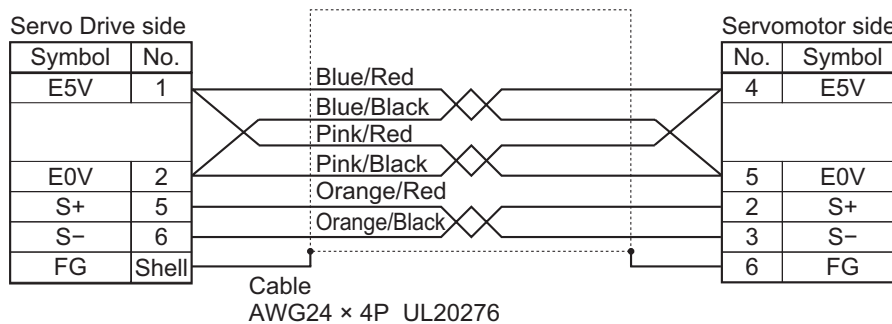

[Servo Drive side connector]
 Connector model
 Crimp-type I/O connector (Molex Japan)
 Connector pin model
 50639-8028 (Molex Japan)

[Servomotor side connector]
 Connector model
 172160-1 (Tyco Electronics AMP KK)
 Connector pin model
 170365-1 (Tyco Electronics AMP KK)

Encoder Cables: Global Flexible Cable (R88A-CRGC□NR)

- **Cable types**
(Incremental encoders: For 3,000-r/min Servomotors of 1 to 5 kW, 2,000-r/min Servomotors of 1 to 5 kW, and 1,000-r/min Servomotors of 900 W to 3 kW)

Model	Length (L)	Outer diameter of sheath	Weight
R88A-CRGC003NR	3 m	7.5 dia.	Approx. 0.4 kg
R88A-CRGC005NR	5 m		Approx. 0.5 kg
R88A-CRGC010NR	10 m		Approx. 0.9 kg
R88A-CRGC015NR	15 m		Approx. 1.3 kg
R88A-CRGC020NR	20 m		Approx. 1.6 kg

- **Connection configuration and external dimensions**

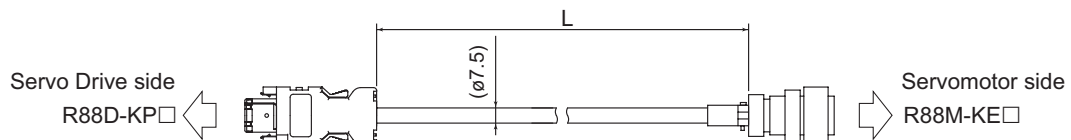

- **Wiring**

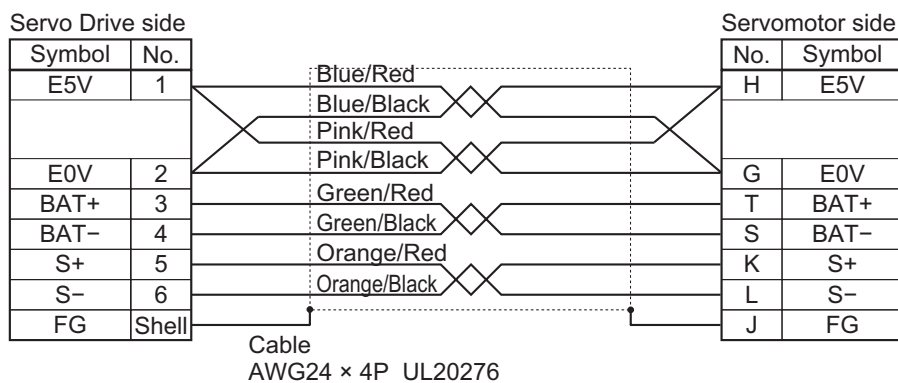

[Servo Drive side connector]
Connector model
Crimp-type I/O connector (Molex Japan)
Connector pin model
50639-8028 (Molex Japan)

[Servomotor side connector]
Straight plug model
N/MS3106B20-29S
(Japan Aviation Electronics)
Cable clamp model
N/MS3057-12A
(Japan Aviation Electronics)

3-5-3 Motor Power Cable Specifications

These cables are used to connect the Servo Drive and Servomotor. Select an appropriate cable for the Servomotor.



Precautions for Correct Use

If the cable is used in a moving environment, use a global flexible cable.

Power Cables without Brake: Global Non-Flexible Cable (R88A-CAGA□S)

● Cable types

For 3,000-r/min Servomotors of 50 to 750 W

Model	Length (L)	Outer diameter of sheath	Weight
R88A-CAGA003S	3 m	6.2 dia.	Approx. 0.2 kg
R88A-CAGA005S	5 m		Approx. 0.3 kg
R88A-CAGA010S	10 m		Approx. 0.6 kg
R88A-CAGA015S	15 m		Approx. 0.9 kg
R88A-CAGA020S	20 m		Approx. 1.2 kg

● Connection configuration and external dimensions

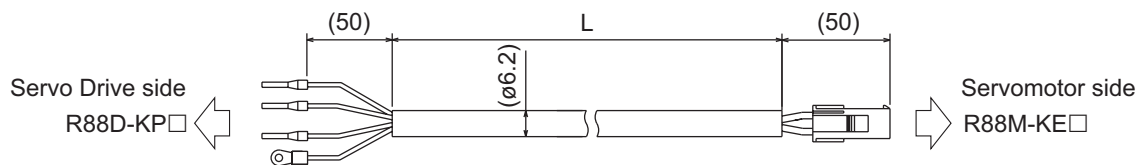

● Wiring

Servo Drive side

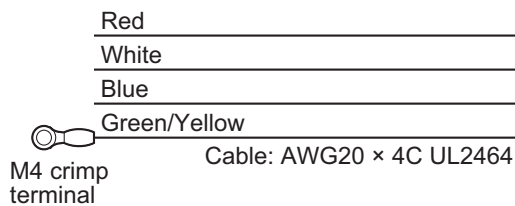

Servomotor side

No.	Symbol
1	Phase U
2	Phase V
3	Phase W
4	FG

[Servomotor side connector]

Connector model

172159-1 (Tyco Electronics AMP KK)

Contact pin model

170362-1 (Tyco Electronics AMP KK)

170366-1 (Tyco Electronics AMP KK)

Power Cables without Brake: Global Non-Flexible Cable (R88A-CAGB□S)

- Cable types

200 V:

(For 3,000-r/min Servomotors of 1 to 2 kW, 2,000-r/min Servomotors of 1 to 2 kW, 1,000-r/min Servomotors of 900 W)

Model	Length (L)	Outer diameter of sheath	Weight
R88A-CAGB003S	3 m	10.4 dia.	Approx. 0.7 kg
R88A-CAGB005S	5 m		Approx. 1.0 kg
R88A-CAGB010S	10 m		Approx. 2.0 kg
R88A-CAGB015S	15 m		Approx. 2.9 kg
R88A-CAGB020S	20 m		Approx. 3.8 kg

- Connection configuration and external dimensions

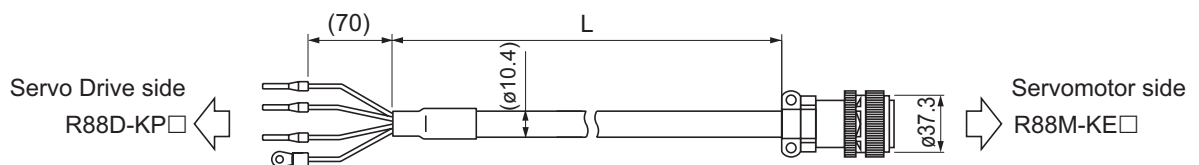

- Wiring

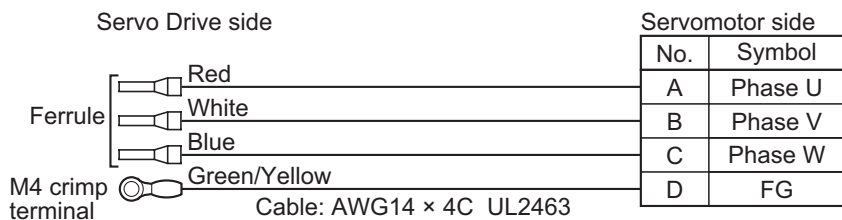

[Servomotor side connector]

Straight plug model

N/MS3106B20-4S (Japan Aviation Electronics)

Cable clamp model

N/MS3057-12A (Japan Aviation Electronics)

Power Cables without Brake: Global Non-Flexible Cable (R88A-CAGD□S)

● Cable types

(For 3,000-r/min Servomotors of 3 to 5 kW, 2,000-r/min Servomotors of 3 to 5 kW, 1,000-r/min Servomotors of 2 to 3 kW)

Model	Length (L)	Outer diameter of sheath	Weight
R88A-CAGD003S	3 m	14.7 dia.	Approx. 1.3 kg
R88A-CAGD005S	5 m		Approx. 2.1 kg
R88A-CAGD010S	10 m		Approx. 4.0 kg
R88A-CAGD015S	15 m		Approx. 6.0 kg
R88A-CAGD020S	20 m		Approx. 8.0 kg

● Connection configuration and external dimensions

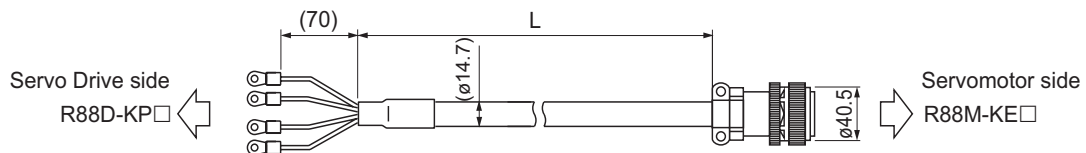

● Wiring

Servo Drive side

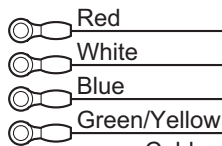

M5 crimp terminal

Cable: AWG10 × 4C UL2463

Servomotor side

No.	Symbol
A	Phase U
B	Phase V
C	Phase W
D	FG

[Servomotor side connector]

Straight plug model

N/MS3106B22-22S (Japan Aviation Electronics)

Cable clamp model

N/MS3057-12A (Japan Aviation Electronics)

Power Cables without Brake: Global Flexible Cable (R88A-CAGA□SR)

● Cable types

For 3,000-r/min Servomotors of 50 to 750 W

Model	Length (L)	Outer diameter of sheath	Weight
R88A-CAGA003SR	3 m	6.9 dia.	Approx. 0.2 kg
R88A-CAGA005SR	5 m		Approx. 0.3 kg
R88A-CAGA010SR	10 m		Approx. 0.7 kg
R88A-CAGA015SR	15 m		Approx. 1.0 kg
R88A-CAGA020SR	20 m		Approx. 1.3 kg

● Connection configuration and external dimensions

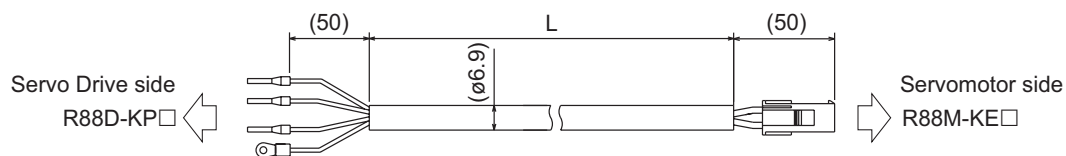

● Wiring

Servo Drive side

Red

White

Blue

Green/Yellow

M4 crimp terminal

Cable: AWG20 × 4C UL2464

Servomotor side

No.	Symbol
1	Phase U
2	Phase V
3	Phase W
4	FG

[Servomotor side connector]

Connector model

172159-1 (Tyco Electronics AMP KK)

Contact pin model

170362-1 (Tyco Electronics AMP KK)

170366-1 (Tyco Electronics AMP KK)

Power Cables without Brake: Global Flexible Cable (R88A-CAGB□SR)

● Cable types

200 V:

(For 3,000-r/min Servomotors of 1 to 2 kW, 2,000-r/min Servomotors of 1 to 2 kW, 1,000-r/min Servomotors of 900 W)

Model	Length (L)	Outer diameter of sheath	Minimum bending radius (R) ^{*1}	Weight
R88A-CAGB003SR	3 m	12.7 dia.	90 mm	Approx. 0.8 kg
R88A-CAGB005SR	5 m			Approx. 1.3 kg
R88A-CAGB010SR	10 m			Approx. 2.4 kg
R88A-CAGB015SR	15 m			Approx. 3.5 kg
R88A-CAGB020SR	20 m			Approx. 4.6 kg

*1 For information on minimum bending radius, refer to 3-5-1 *Resistance to Bending of Global Flexible Cable* on page 3-62.

● Connection configuration and external dimensions

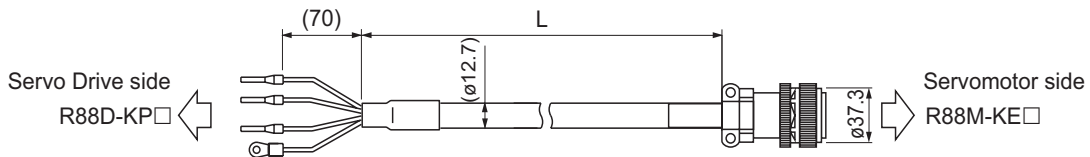

● Wiring

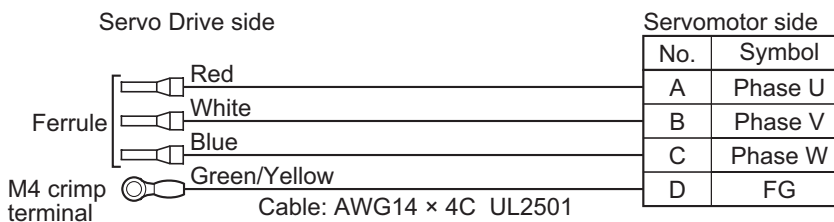

[Servomotor side connector]

Straight plug model

N/MS3106B20-4S (Japan Aviation Electronics)

Cable clamp model

N/MS3057-12A (Japan Aviation Electronics)

Power Cables without Brake: Global Flexible Cable (R88A-CAGD□SR)

- **Cable types**
(For 3,000-r/min Servomotors of 3 to 5 kW, 2,000-r/min Servomotors of 3 to 5 kW, 1,000-r/min Servomotors of 2 to 3 kW)

Model	Length (L)	Outer diameter of sheath	Minimum bending radius (R) ^{*1}	Weight
R88A-CAGD003SR	3 m	15.6 dia.	100 mm	Approx. 1.4 kg
R88A-CAGD005SR	5 m			Approx. 2.2 kg
R88A-CAGD010SR	10 m			Approx. 4.2 kg
R88A-CAGD015SR	15 m			Approx. 6.3 kg
R88A-CAGD020SR	20 m			Approx. 8.3 kg

*1 For information on minimum bending radius, refer to 3-5-1 *Resistance to Bending of Global Flexible Cable* on page 3-62.

- **Connection configuration and external dimensions**

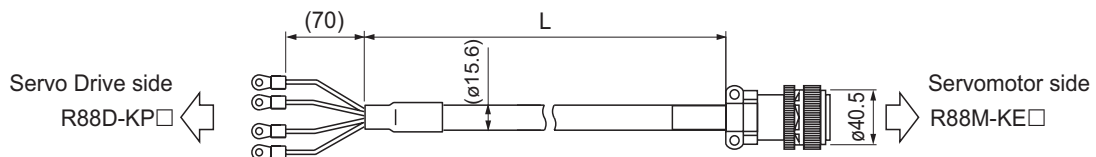

- **Wiring**

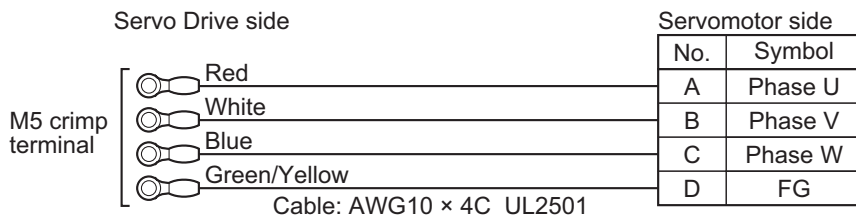

[Servomotor side connector]

Straight plug model

N/MS3106B22-22S (Japan Aviation Electronics)

Cable clamp model

N/MS3057-12A (Japan Aviation Electronics)

Power Cables with Brake: Global Non-Flexible Cable (R88A-CAGB□B)

- Cable types

200 V:

(For 3,000-r/min Servomotors of 1 to 2 kW, 2,000-r/min Servomotors of 1 to 2 kW, 1,000-r/min Servomotors of 900 W)

Model	Length (L)	Outer diameter of sheath	Weight
R88A-CAGB003B	3 m	10.4 dia./5.4 dia.	Approx. 0.8 kg
R88A-CAGB005B	5 m		Approx. 1.3 kg
R88A-CAGB010B	10 m		Approx. 2.4 kg
R88A-CAGB015B	15 m		Approx. 3.5 kg
R88A-CAGB020B	20 m		Approx. 4.6 kg

- Connection configuration and external dimensions

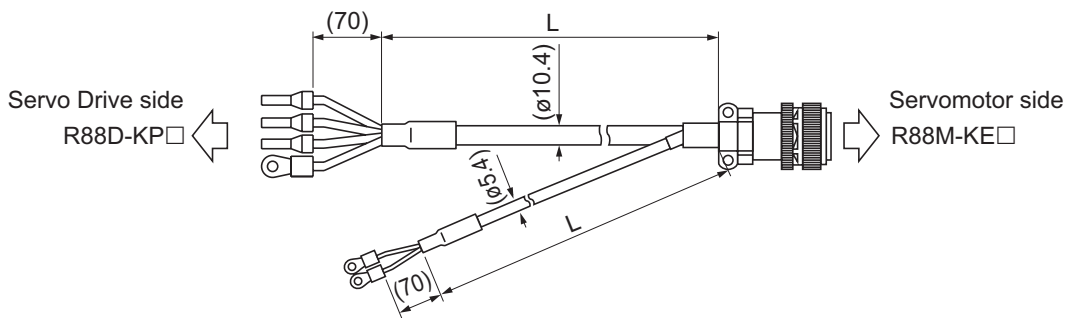

- Wiring

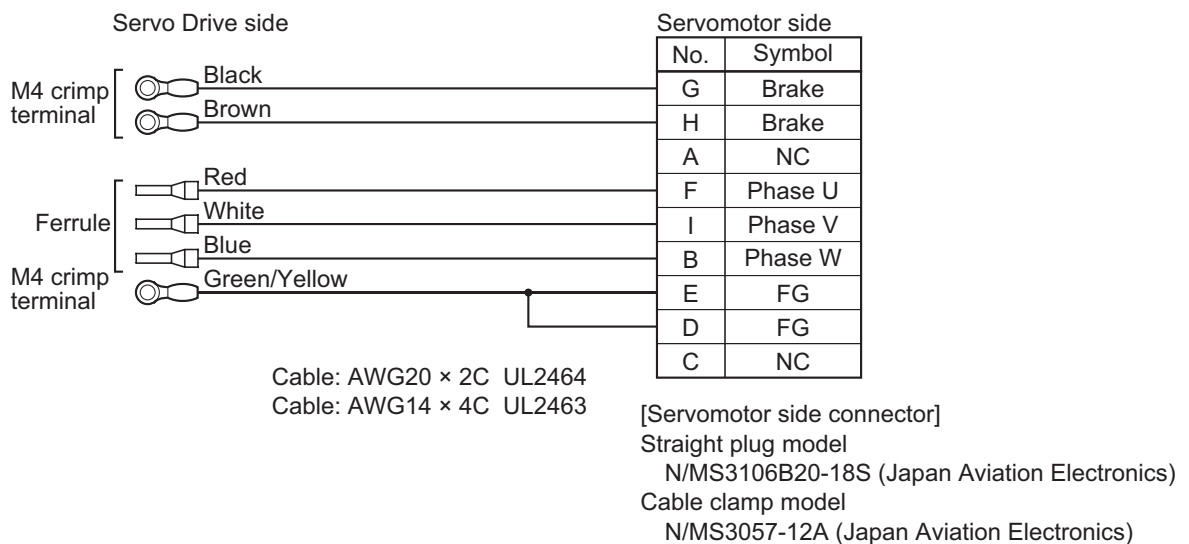

Power Cables with Brake: Global Non-Flexible Cable (R88A-CAGD□B)

- **Cable types**
(For 3,000-r/min Servomotors of 3 to 5 kW, 2,000-r/min Servomotors of 3 to 5 kW, 1,000-r/min Servomotors of 2 to 3 kW)

Model	Length (L)	Outer diameter of sheath	Weight
R88A-CAGD003B	3 m	14.7 dia./5.4 dia.	Approx. 1.5 kg
R88A-CAGD005B	5 m		Approx. 2.4 kg
R88A-CAGD010B	10 m		Approx. 4.5 kg
R88A-CAGD015B	15 m		Approx. 6.7 kg
R88A-CAGD020B	20 m		Approx. 8.8 kg

- **Connection configuration and external dimensions**

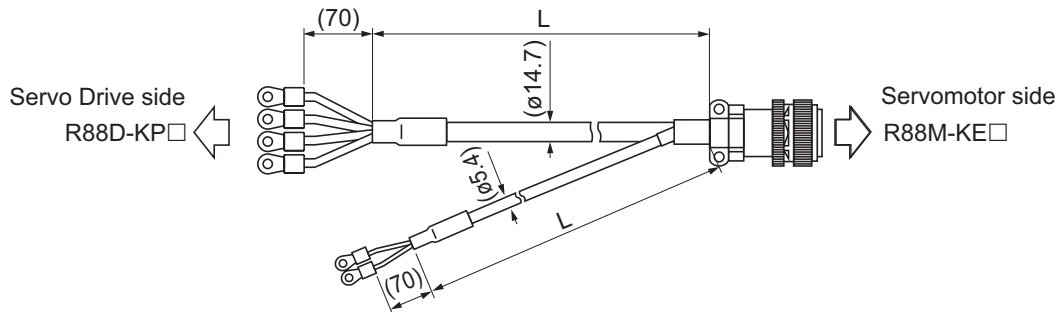

- **Wiring**

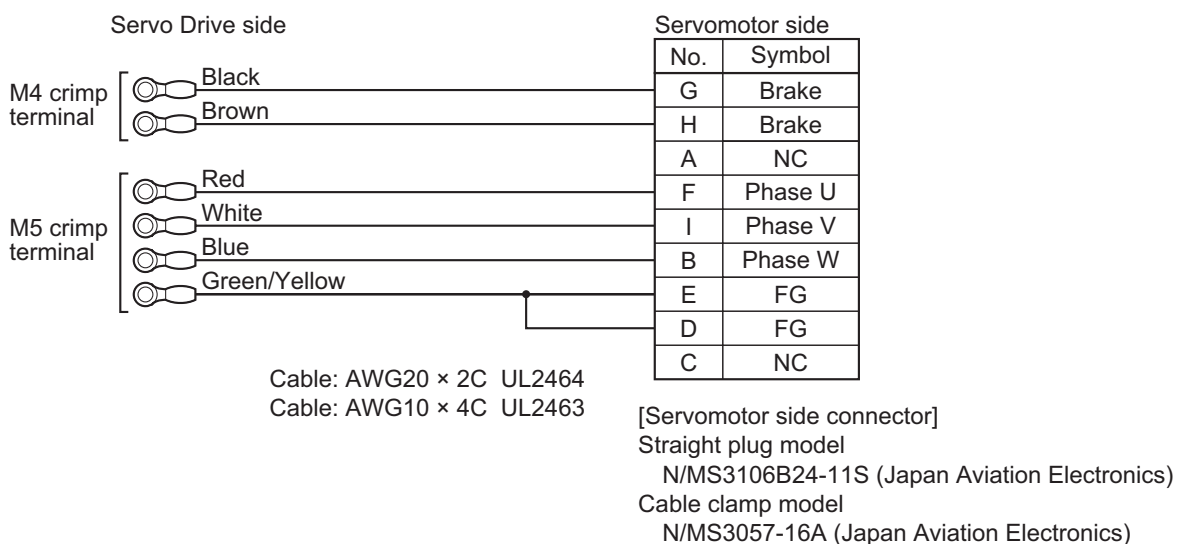

Power Cables with Brake: Global Flexible Cable (R88A-CAGB□BR)

● Cable types

200 V:

(For 3,000-r/min Servomotors of 1 to 2 kW, 2,000-r/min Servomotors of 1 to 2 kW, 1,000-r/min Servomotors of 900 W)

Model	Length (L)	Outer diameter of sheath	Minimum bending radius (R) ^{*1}	Weight
R88A-CAGB003BR	3 m	12.7 dia./ 6.1 dia.	Power cable part: 90 mm	Approx. 0.9 kg
R88A-CAGB005BR	5 m			Approx. 1.5 kg
R88A-CAGB010BR	10 m		Brake cable part: 45 mm	Approx. 2.8 kg
R88A-CAGB015BR	15 m			Approx. 4.2 kg
R88A-CAGB020BR	20 m			Approx. 5.5 kg

*1 For information on minimum bending radius, refer to 3-5-1 Resistance to Bending of Global Flexible Cable on page 3-62.

● Connection configuration and external dimensions

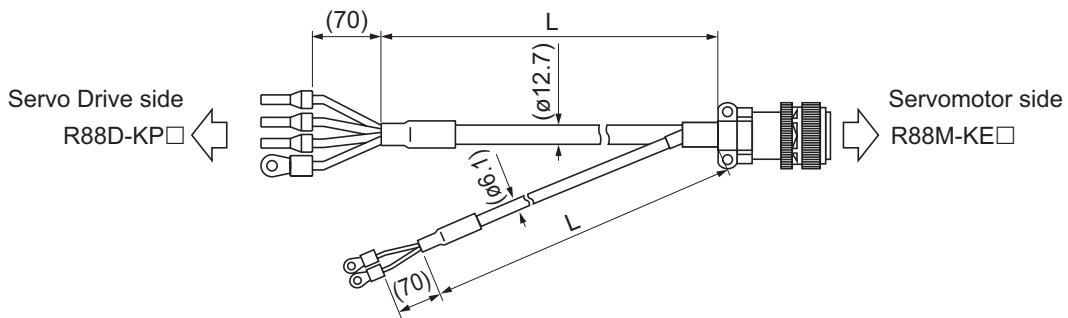

● Wiring

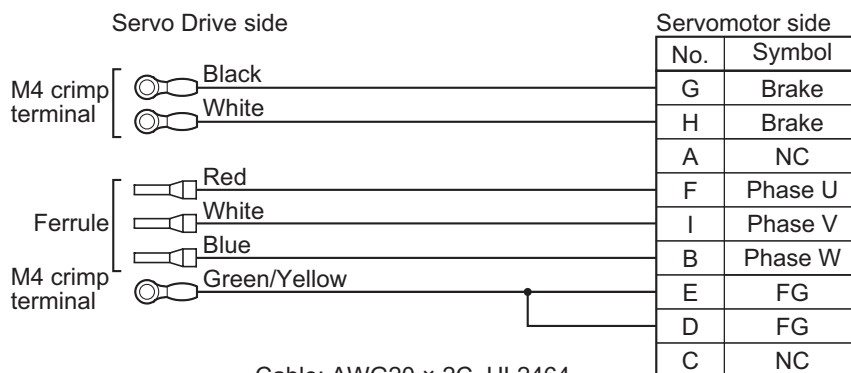

Cable: AWG20 × 2C UL2464

Cable: AWG14 × 4C UL2501

[Servomotor side connector]

Straight plug model

N/MS3106B20-18S (Japan Aviation Electronics)

Cable clamp model

N/MS3057-12A (Japan Aviation Electronics)

Power Cables with Brake: Global Flexible Cable (R88A-CAGD□BR)

- **Cable types**
(For 3,000-r/min Servomotors of 3 to 5 kW, 2,000-r/min Servomotors of 3 to 5 kW, 1,000-r/min Servomotors of 2 to 3 kW)

Model	Length (L)	Outer diameter of sheath	Minimum bending radius (R) ^{*1}	Weight
R88A-CAGD003BR	3 m	15.6 dia./ 6.1 dia.	Power cable part: 100 mm	Approx. 1.6 kg
R88A-CAGD005BR	5 m			Approx. 2.5 kg
R88A-CAGD010BR	10 m		Brake cable part: 45 mm	Approx. 4.7 kg
R88A-CAGD015BR	15 m			Approx. 7.0 kg
R88A-CAGD020BR	20 m			Approx. 9.2 kg

*1 For information on minimum bending radius, refer to 3-5-1 Resistance to Bending of Global Flexible Cable on page 3-62.

- **Connection configuration and external dimensions**

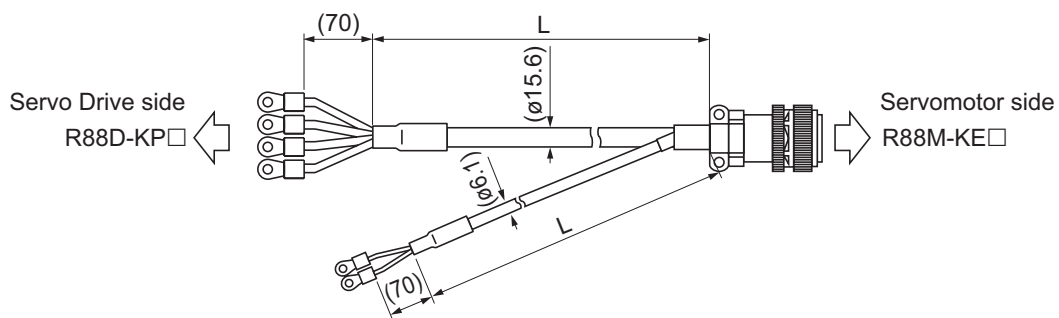

- **Wiring**

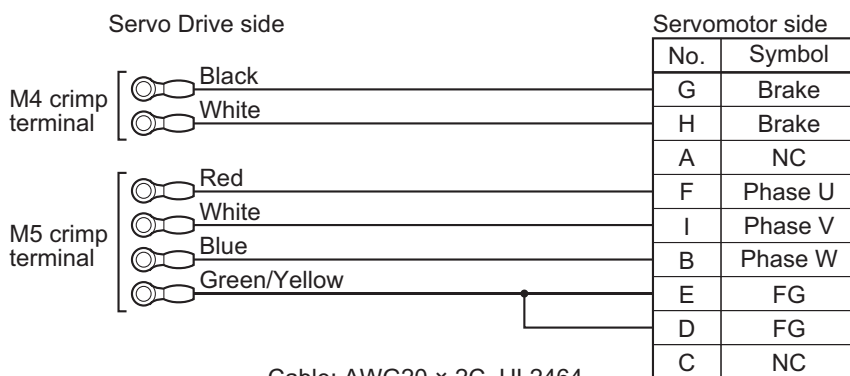

Cable: AWG20 × 2C UL2464
Cable: AWG10 × 4C UL2501

[Servomotor side connector]
Straight plug model
N/MS3106B24-11S (Japan Aviation Electronics)
Cable clamp model
N/MS3057-16A (Japan Aviation Electronics)

Brake Cables: Global Non-Flexible Cable (R88A-CAGA□B)

- **Cable types**
For 3,000-r/min Servomotors of 50 to 750 W

Model	Length (L)	Outer diameter of sheath	Weight
R88A-CAGA003B	3 m	5.4 dia.	Approx. 0.1 kg
R88A-CAGA005B	5 m		Approx. 0.2 kg
R88A-CAGA010B	10 m		Approx. 0.4 kg
R88A-CAGA015B	15 m		Approx. 0.6 kg
R88A-CAGA020B	20 m		Approx. 0.8 kg

- **Connection configuration and external dimensions**

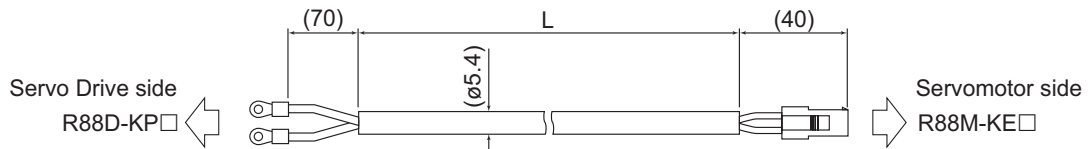

- **Wiring**

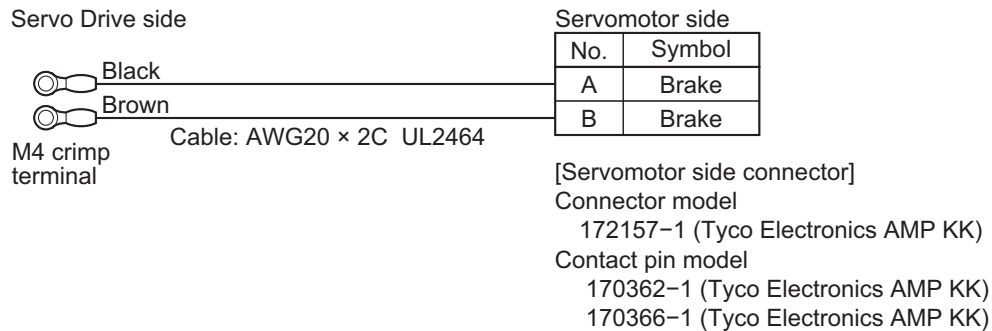

Brake Cables: Global Flexible Cable (R88A-CAGA□BR)

● Cable types

For 3,000-r/min Servomotors of 50 to 750 W

Model	Length (L)	Outer diameter of sheath	Weight
R88A-CAGA003BR	3 m	6.1 dia.	Approx. 0.1 kg
R88A-CAGA005BR	5 m		Approx. 0.2 kg
R88A-CAGA010BR	10 m		Approx. 0.4 kg
R88A-CAGA015BR	15 m		Approx. 0.7 kg
R88A-CAGA020BR	20 m		Approx. 0.9 kg

● Connection configuration and external dimensions

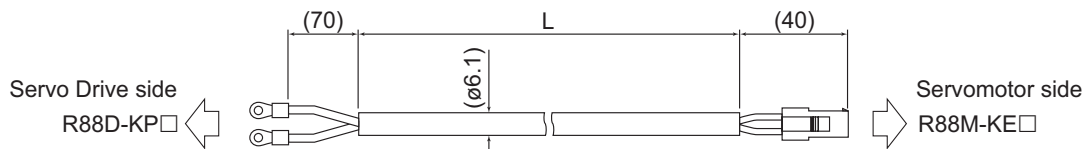

● Wiring

Servo Drive side

Black
White

M4 crimp terminal

Cable: AWG20 × 2C UL2464

Servomotor side

No.	Symbol
A	Brake
B	Brake

[Servomotor side connector]

Connector model

172157-1 (Tyco Electronics AMP KK)

Contact pin model

170362-1 (Tyco Electronics AMP KK)

170366-1 (Tyco Electronics AMP KK)

3-5-4 Connector Specifications

Control I/O Connector (R88A-CNU11C)

This connector is connected to the Servo Drive's control I/O connector (CN1).

Use this connector when preparing a control cable by yourself.

For wiring methods, refer to *Control Cable Specifications* on page 3-84.

This connector is soldered.

● External Dimensions

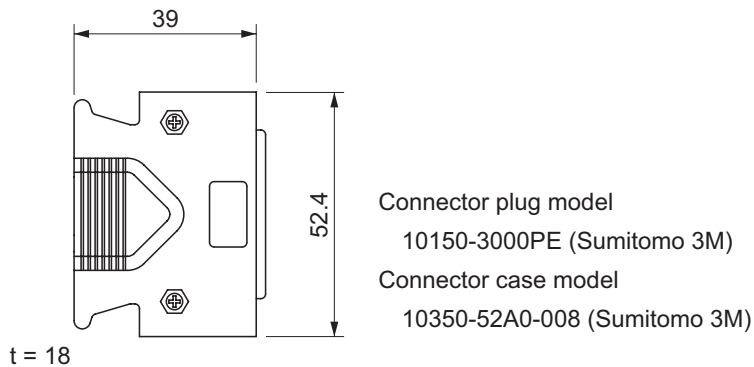

Encoder Connectors

These connectors are used for encoder cables.

Use them when preparing an encoder cable by yourself.

For wiring methods, refer to *Encoder Cable Specifications* on page 3-64.

● External Dimensions

R88A-CNW01R (Drive's CN2 side)

This connector is soldered.

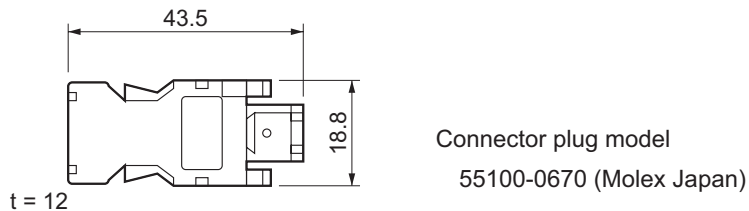

R88A-CNG02R (Servomotor side)

Use the following cable.

- Applicable wire: AWG22 max.
- Insulating cover outer diameter: 1.75 mm dia. max.

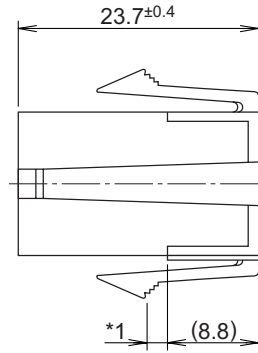
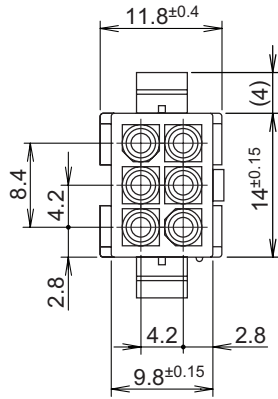

Panel mounting hole

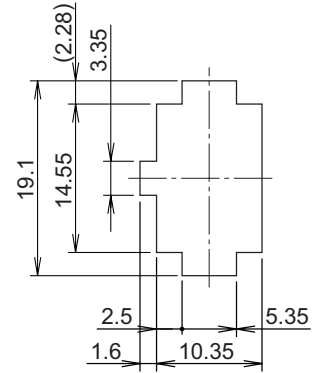

Connector housing model

172160-1 (Tyco Electronics AMP KK)

Contact socket model

170365-1 (Tyco Electronics AMP KK)

*1 The applicable panel thickness is 0.8 to 2.0 mm.

Power Cable Connector (R88A-CNG01A)

This connector is used for power cables.

Use it when preparing a power cable by yourself.

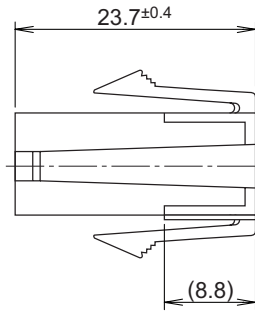
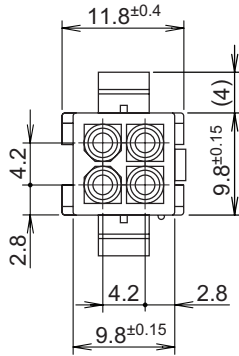

Panel mounting hole

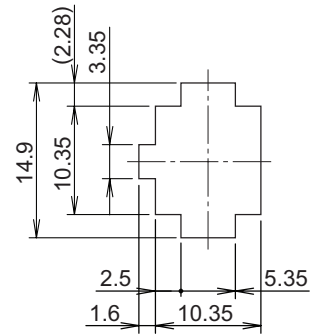

Connector housing model
172159-1 (Tyco Electronics AMP KK)
Contact socket model
170366-1 (Tyco Electronics AMP KK)

The applicable panel thickness is 0.8 to 2.0 mm.

Brake Cable Connector (R88A-CNG01B)

This connector is used for brake cables.

Use it when preparing a brake cable by yourself.

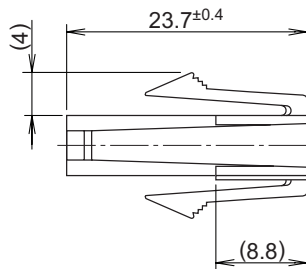
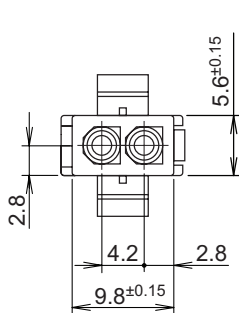

Panel mounting hole

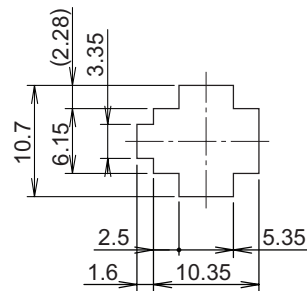

Connector housing model
172157-1 (Tyco Electronics AMP KK)
Contact socket model
170366-1 (Tyco Electronics AMP KK)

The applicable panel thickness is 0.8 to 2.0 mm.

3-5-5 Analog Monitor Cable Specifications

Analog Monitor Cable (R88A-CMK001S)

- Connection configuration and external dimensions

Symbol	No.	
AM1	1	Red
AM2	2	White
GND	3	Black
	4	
	5	
	6	

Cable: AWG24 x 3C UL1007

Connector housing: 51004-0600 (Molex Japan)

Connector terminal: 50011-8000 (Molex Japan)

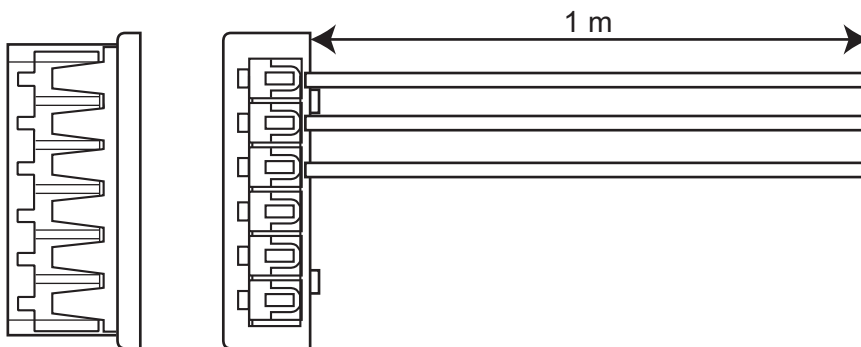

3-5-6 Control Cable Specifications

Specified Cables for Position Control Unit (Specified Cables for CJ1W-NC□□4)

These cables are used to connect to the Position Control Unit (Model: CJ1W-NC□□4) for OMRON SYSMAC CJ-series Programmable Controllers. There are two types of cables: 1-axis type and 2-axis type.

The applicable Position Control Unit models are as follows.

CJ1W-NC214/-NC414/-NC234/-NC434

● Cable types

- Cables for Line Driver Output 1 Axis

Model	Length
XW2Z-100J-G9	1 m
XW2Z-500J-G9	5 m
XW2Z-10MJ-G9	10 m

- Cables for Open Collector Output 1 Axis

Model	Length
XW2Z-100J-G13	1 m
XW2Z-300J-G13	3 m

- Cables for Line Driver Output 2 Axes

Model	Length
XW2Z-100J-G1	1 m
XW2Z-500J-G1	5 m
XW2Z-10MJ-G1	10 m

- Cables for Open Collector Output 2 Axes

Model	Length
XW2Z-100J-G5	1 m
XW2Z-300J-G5	3 m

● Connection configuration and external dimensions

- Cables for 1 Axis

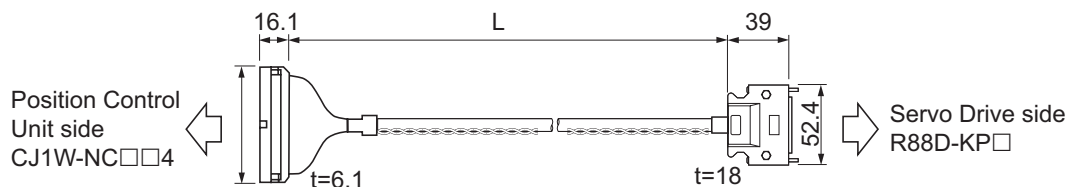

- Cables for 2 Axes

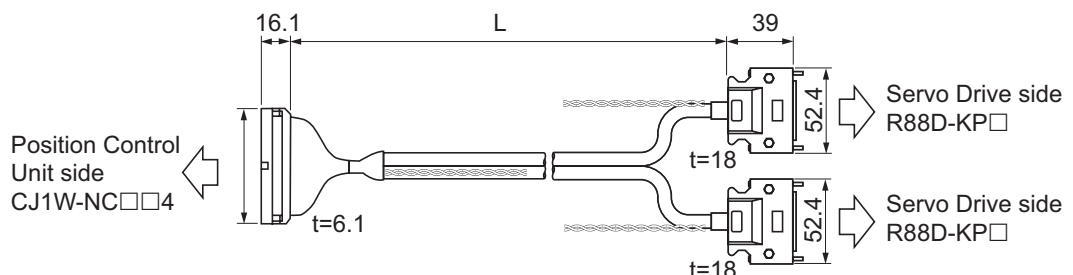

● **Wiring**

- Cables for Line Driver Output 1 Axis

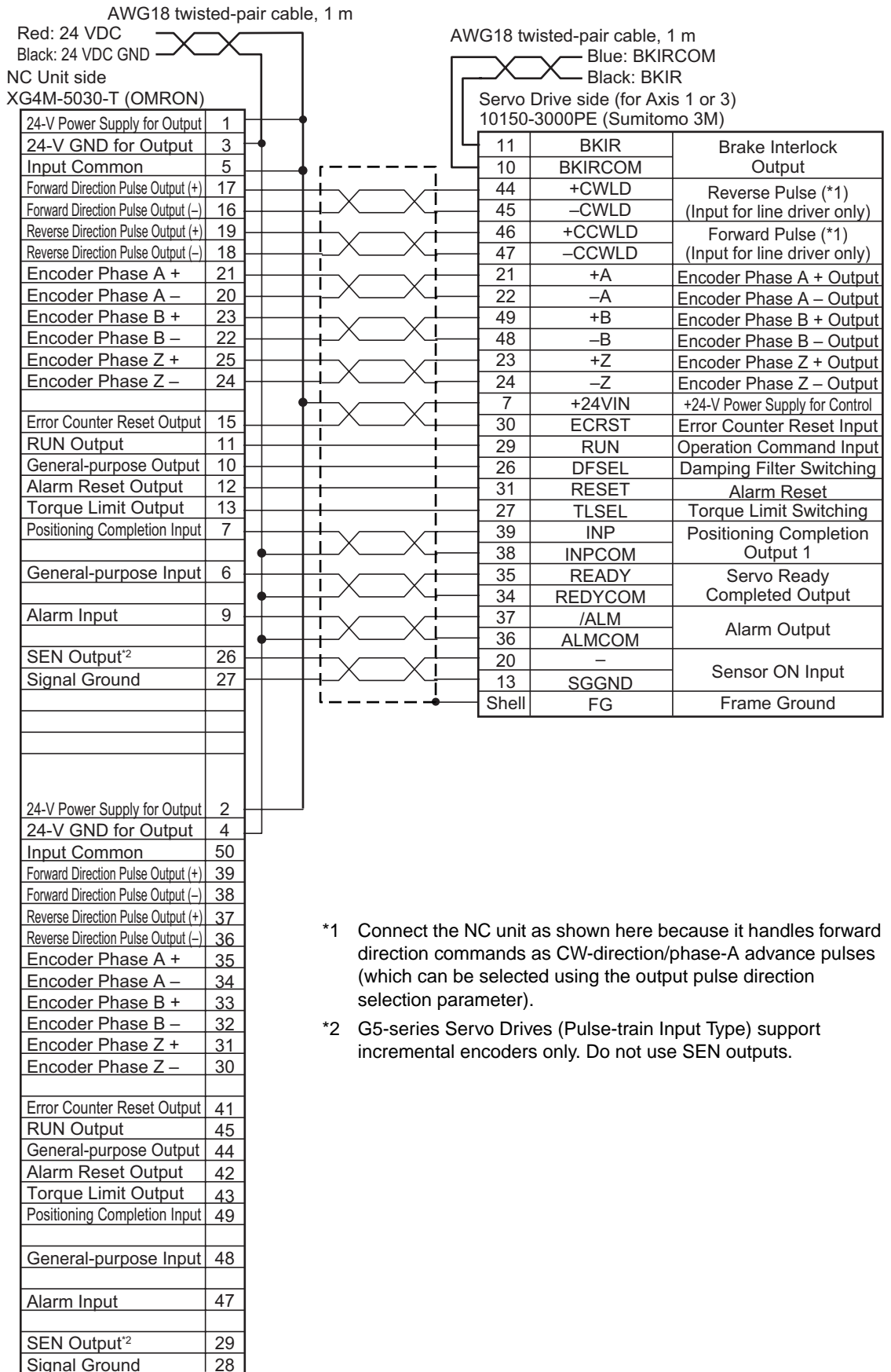

*1 Connect the NC unit as shown here because it handles forward direction commands as CW-direction/phase-A advance pulses (which can be selected using the output pulse direction selection parameter).

*2 G5-series Servo Drives (Pulse-train Input Type) support incremental encoders only. Do not use SEN outputs.

• Cables for Open Collector Output 1 Axis

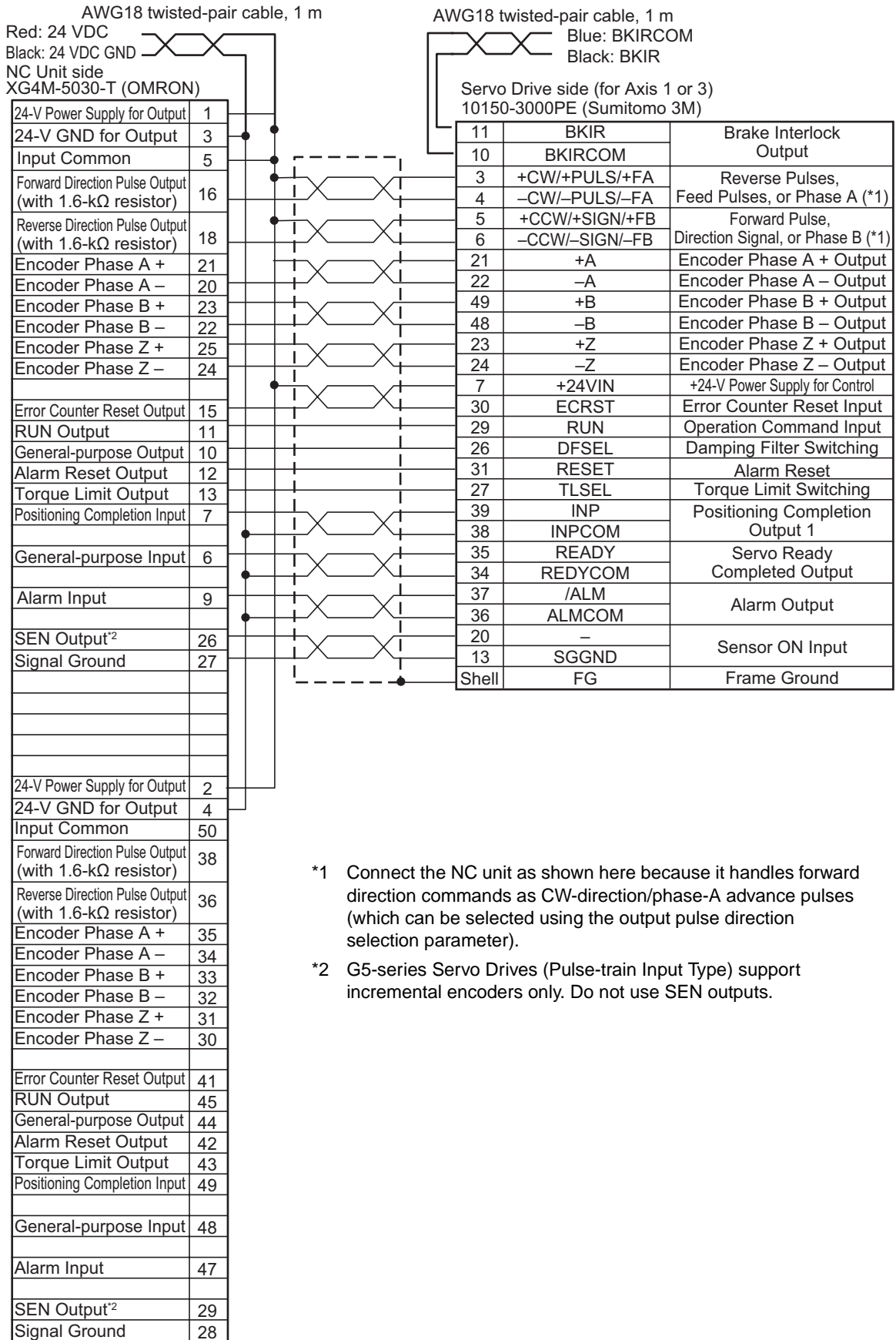

*1 Connect the NC unit as shown here because it handles forward direction commands as CW-direction/phase-A advance pulses (which can be selected using the output pulse direction selection parameter).

*2 G5-series Servo Drives (Pulse-train Input Type) support incremental encoders only. Do not use SEN outputs.

• Cables for Line Driver Output 2 Axes

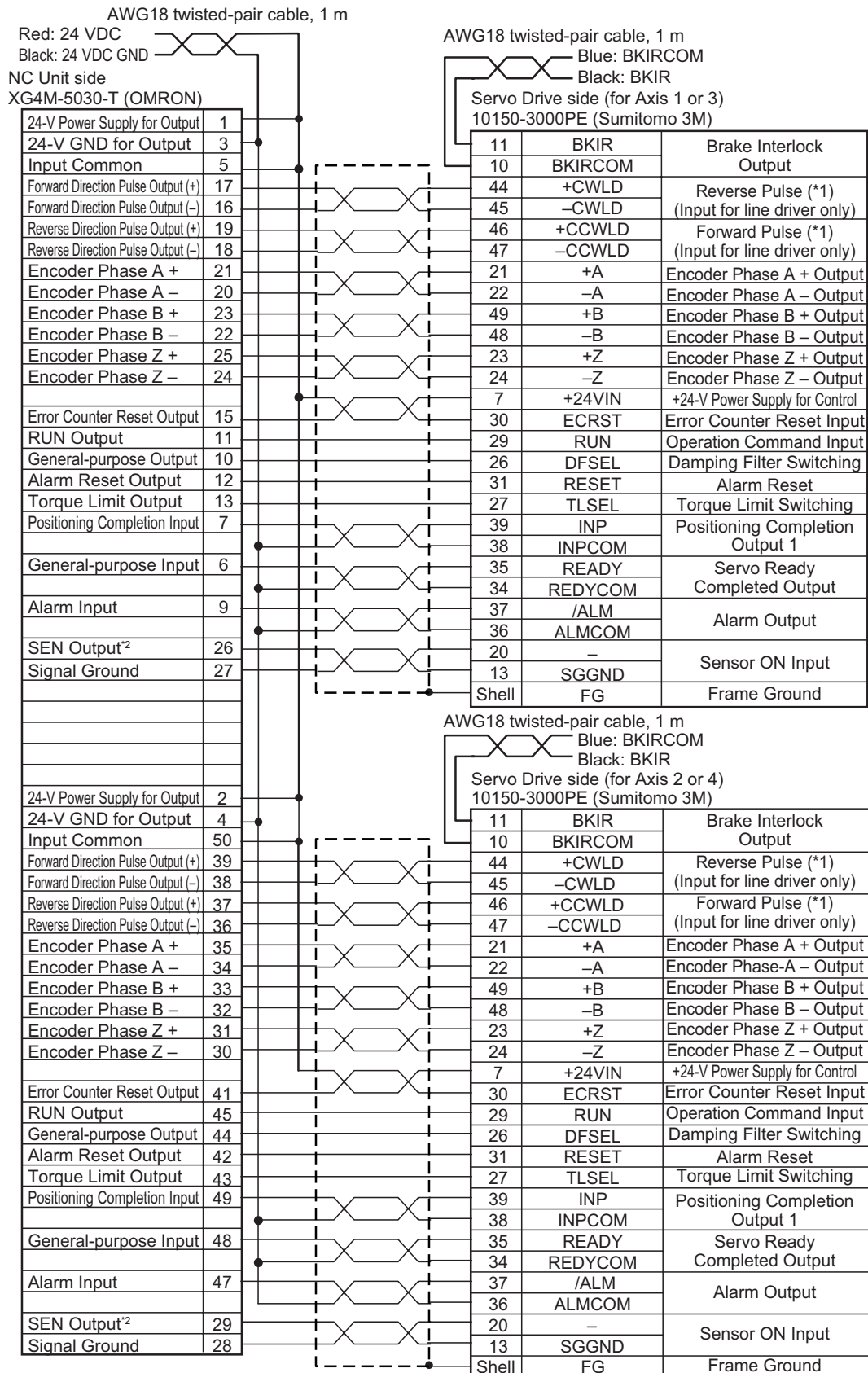

*1 Connect the NC unit as shown here because it handles forward direction commands as CW-direction/phase-A advance pulses (which can be selected using the output pulse direction selection parameter).

*2 G5-series Servo Drives (Pulse-train Input Type) support incremental encoders only. Do not use SEN outputs.

• Cables for Open Collector Output 2 Axes

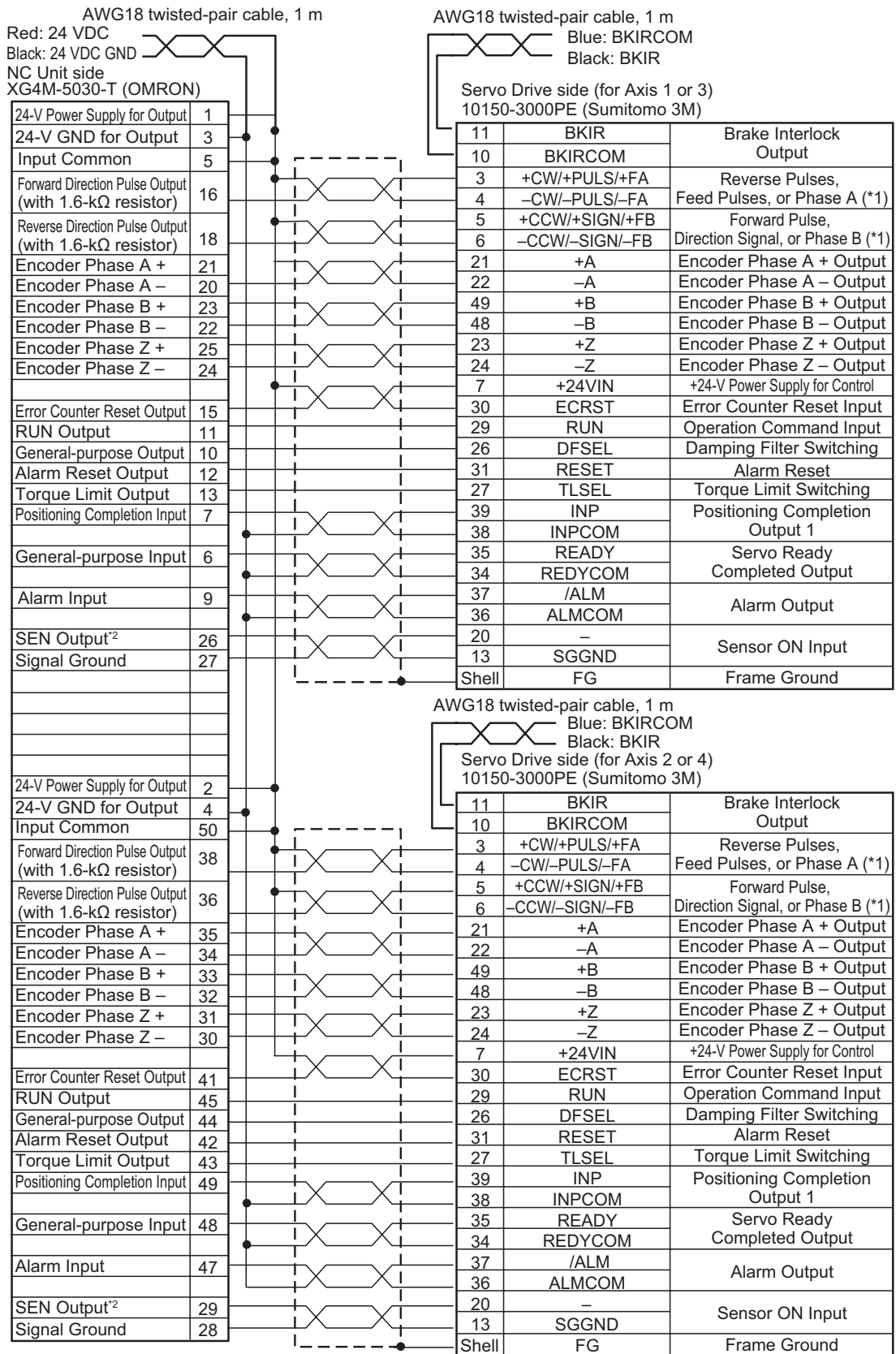

*1 Connect the NC unit as shown here because it handles forward direction commands as CW-direction/phase-A advance pulses (which can be selected using the output pulse direction selection parameter).

*2 G5-series Servo Drives (Pulse-train Input Type) support incremental encoders only. Do not use SEN outputs.

General-purpose Control Cables (R88A-CPG□S)

This cable has a connector to be connected to the Servo Drive's control I/O connector (CN1). The connector for the controller is not provided. To connect the Servo Drive with a non-OMRON controller, or a Position Control Unit which does not have a specified cable, wire and prepare an appropriate connector for the controller to be connected.

- If connecting the Servo Drive with a controller which does not have a specified cable, you can use this general-purpose control cable, or a connector terminal block cable in conjunction with a connector terminal block.

● Cable types

Model	Length (L)	Outer diameter of sheath	Weight
R88A-CPG001S	1 m	12.8 dia.	Approx. 0.3 kg
R88A-CPG002S	2 m		Approx. 0.6 kg

● Connection configuration and external dimensions

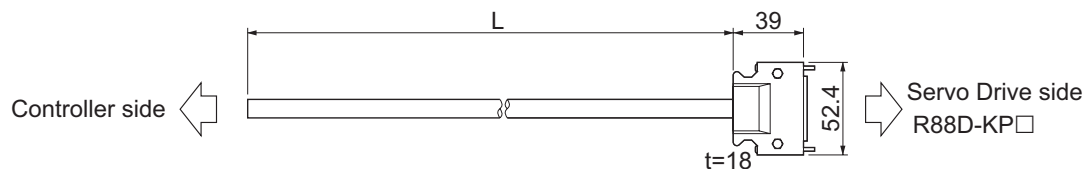

● Wiring

No.	Color of wire/ mark	Symbol
1	Orange/Red (1)	+24VCW
2	Orange/Black (1)	+24VCCW
3	Gray/Red (1)	+CW/+PULS/+FA
4	Gray/Black (1)	-CW/-PULS/-FA
5	White/Red (1)	+CCW/+SIGN/+FB
6	White/Black (1)	-CCW/-SIGN/-FB
7	Yellow/Red (1)	+24VIN
8	Pink/Red (1)	SI1
9	Pink/Black (1)	SI2
10	Orange/Red (2)	SO1-
11	Orange/Black (2)	SO1+
12	Yellow/Black (1)	—
13	Gray/Black (2)	SGGND
14	White/Red (2)	—
15	White/Black (2)	SGGND
16	Yellow/Red (2)	—
17	Yellow/Black (2) or Pink/Black (2)	SGGND
18	Pink/Red (2)	—
19	Orange/Red (5)	Z
20	Gray/Red (2)	—
21	Orange/Red (3)	+A
22	Orange/Black (3)	-A
23	Gray/Red (3)	+Z
24	Gray/Black (3)	-Z
25	Orange/Black (5)	SGGND
26	White/Red (3)	SI3

No.	Color of wire/ mark	Symbol
27	Pink/Black (3)	SI4
28	White/Black (3)	SI5
29	Yellow/Red (3)	SI6
30	Pink/Red (3)	SI7
31	Yellow/Black (3)	SI8
32	Gray/Black (4)	SI9
33	Orange/Red (4)	SI10
34	White/Red (4)	S02-
35	White/Black (4)	S02+
36	Yellow/Red (4)	ALMCOM
37	Yellow/Black (4)	/ALM
38	Pink/Red (4)	S03-
39	Pink/Black (4)	S03+
40	Gray/Red (4)	—
41	Orange/Black (4)	—
42	Gray/Red (5)	—
43	Gray/Black (5)	—
44	White/Red (5)	+CWLD
45	White/Black (5)	-CWLD
46	Yellow/Red (5)	+CCWLD
47	Yellow/Black (5)	-CCWLD
48	Pink/Black (5)	-B
49	Pink/Red (5)	+B
50	—	—
Shell	—	FG

Connector plug model: 10150-3000PE (Sumitomo 3M)

Connector case model: 10350-52A0-008 (Sumitomo 3M)

Cable: AWG24 x 25P UL20276

- Wires with the same wire color and the same number of marks form a twisted pair.
Example: The wire described as Orange/Red (1) and that described as Orange/Black (1) are paired and twisted together.

Connector Terminal Block Cables (XW2Z-□J-B24)

This connector terminal block cable is connected to the Servo Drive's control I/O connector (CN1). All of the pins in the control I/O connector (CN1) can be converted to terminals on the terminal block.

● Cable types

Model	Length (L)	Outer diameter of sheath	Weight
XW2Z-100J-B24	1 m	11.2 dia.	Approx. 0.2 kg
XW2Z-200J-B24	2 m		Approx. 0.4 kg

● Connection configuration and external dimensions

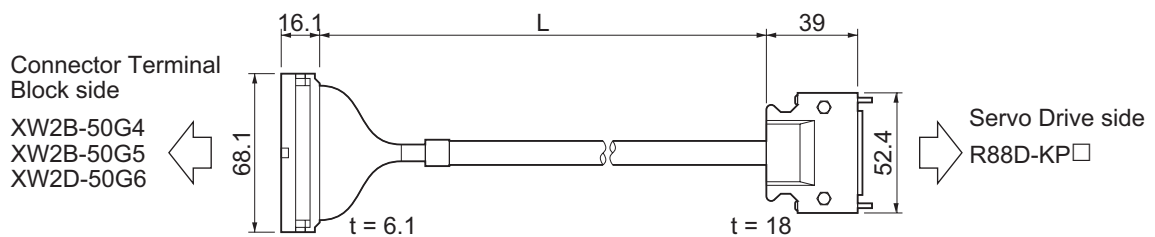

Terminal block		Connector	Servo Drive side		
No.	No.		No.	Color of wire/mark	Symbol
1	1	[Twisted]	1	Blue/Red (1)	+24VCW
2	2		2	Blue/Black (1)	+24VCCW
3	3	[Twisted]	3	Pink/Red (1)	+CW/+PULS/+FA
4	4		4	Pink/Black (1)	-CW/-PULS/-FA
5	5	[Twisted]	5	Green/Red (1)	+CCW/+SIGN/+FB
6	6		6	Green/Black (1)	-CCW/-SIGN/-FB
7	7	[Twisted]	7	Orange/Red (1)	+24VIN
8	8		8	Gray/Red (1)	SI1
9	9	[Twisted]	9	Gray/Black (1)	SI2
10	10		10	Blue/Red (2)	SO1-
11	11	[Twisted]	11	Blue/Black (2)	SO1+
13	13		13	Pink/Red (2)	SGGND
20	20	[Twisted]	20	Pink/Black (2)	---
14	14		14	Green/Red (2)	---
15	15	[Twisted]	15	Green/Black (2)	SGGND
16	16		16	Orange/Red (2)	---
17	17	[Twisted]	17	Orange/Black (2)	SGGND
18	18		18	Gray/Red (2)	---
12	12	[Twisted]	12	Gray/Black (2)	---
19	19		19	Blue/Red (3)	Z
25	25	[Twisted]	25	Blue/Black (3)	SGGND
21	21		21	Pink/Red (3)	+A
22	22	[Twisted]	22	Pink/Black (3)	-A
23	23		23	Green/Red (3)	+Z
24	24	[Twisted]	24	Green/Black (3)	-Z
26	26		26	Orange/Red (3)	SI3
27	27	[Twisted]	27	Orange/Black (3)	SI4
28	28		28	Gray/Red (3)	SI5
29	29	[Twisted]	29	Gray/Black (3)	SI6
30	30		30	Blue/Red (4)	SI7
31	31	[Twisted]	31	Blue/Black (4)	SI8
32	32		32	Pink/Red (4)	SI9
33	33	[Twisted]	33	Pink/Black (4)	SI10
34	34		34	Green/Red (4)	SO2-
35	35	[Twisted]	35	Green/Black (4)	SO2+
36	36		36	Orange/Red (4)	ALMCOM
37	37	[Twisted]	37	Orange/Black (4)	/ALM
38	38		38	Gray/Red (4)	SO3-
39	39	[Twisted]	39	Gray/Black (4)	SO3+
40	40		40	Blue/Red (5)	---
41	41	[Twisted]	41	Blue/Black (5)	---
42	42		42	Pink/Red (5)	---
43	43	[Twisted]	43	Pink/Black (5)	---
44	44		44	Green/Red (5)	+CWLD
45	45	[Twisted]	45	Green/Black (5)	-CWLD
46	46		46	Orange/Red (5)	+CCWLD
47	47	[Twisted]	47	Orange/Black (5)	-CCWLD
48	48		48	Gray/Red (5)	-B
49	49	[Twisted]	49	Gray/Black (5)	+B
50	50		50	Orange/Black (1)	---
			Shell	FG	

- Wires with the same wire color and the same number of marks form a twisted pair.

Example: The wire described as Yellow/Black (1) and that described as Pink/Black (1) are paired and twisted together.

Drive connector

- Connector plug model: 10150-3000PE (Sumitomo 3M)
- Connector case model: 10350-52A0-008 (Sumitomo 3M)

Connector terminal block connector

- Connector socket model: XG4M-5030 (OMRON)
- Strain relief model: XG4T-5004 (OMRON)

Cable

- AWG28 x 25P UL2464

Connector Terminal Block Conversion Unit

The Connector Terminal Block Conversion Unit is used in combination with a Connector Terminal Block Cable (Model: XW2Z-□J-B24) to convert the Servo Drive's control I/O connector (CN1) to the terminal block.

● XW2B-50G4 (M3 Screw Terminal Block)

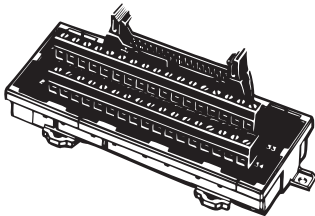

• External Dimensions

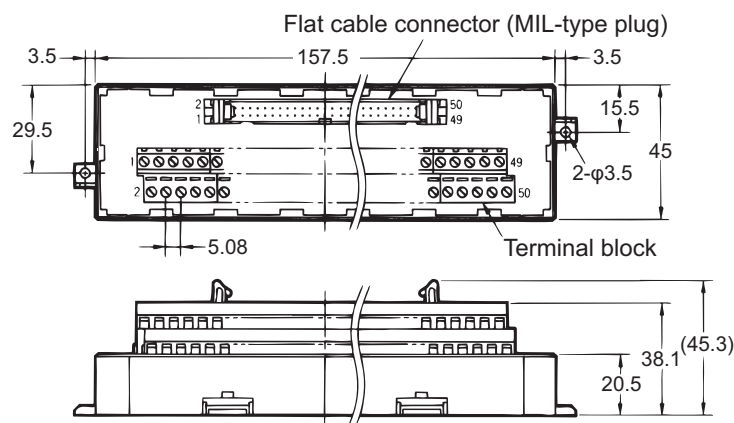

- Use 0.3 to 1.25 mm² wire (AWG22 to 16).
- The wire inlet is 1.8 mm (height) x 2.5 mm (width).
- Strip the insulation from the end of the wire as shown below.

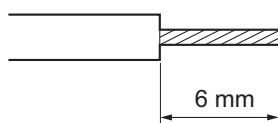

● XW2B-50G5 (M3.5 Screw Terminal Block)

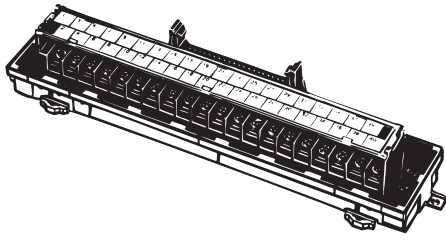

• External Dimensions

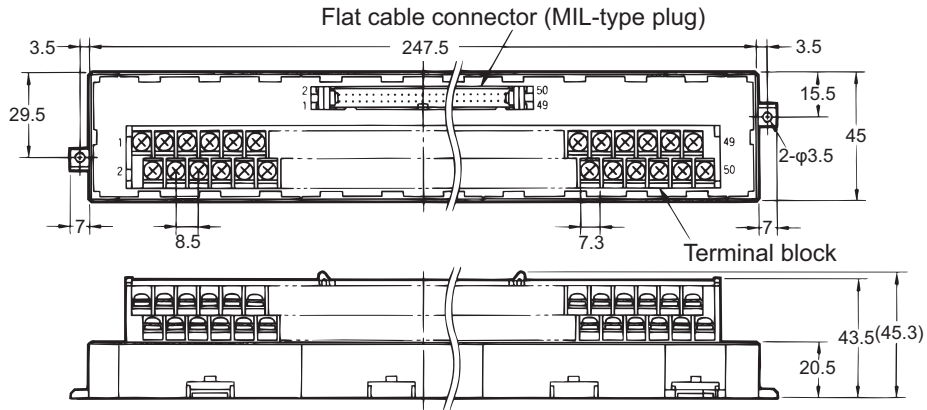

- When using crimp terminals, use crimp terminals with the following dimensions.
- When connecting wires and crimp terminals to a terminal block, tighten them to a torque of 0.59 N·m.

Round terminal

Fork terminal

φ3.2 mm

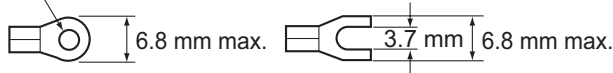

Applicable crimp terminals		Applicable wires
Round terminals	1.25-3	AWG22 to 16 (0.3 to 1.25 mm ²)
	2-3.5	AWG16 to 14 (1.25 to 2.0 mm ²)
Fork terminals	1.25Y-3	AWG22 to 16 (0.3 to 1.25 mm ²)
	2-3.5	AWG16 to 14 (1.25 to 2.0 mm ²)

● XW2D-50G6 (M3 Screw Terminal Block)

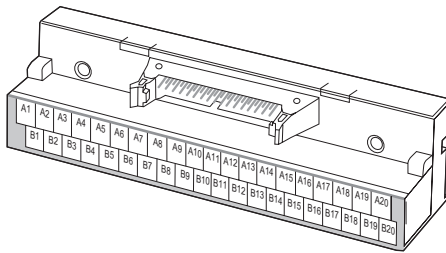

• External Dimensions

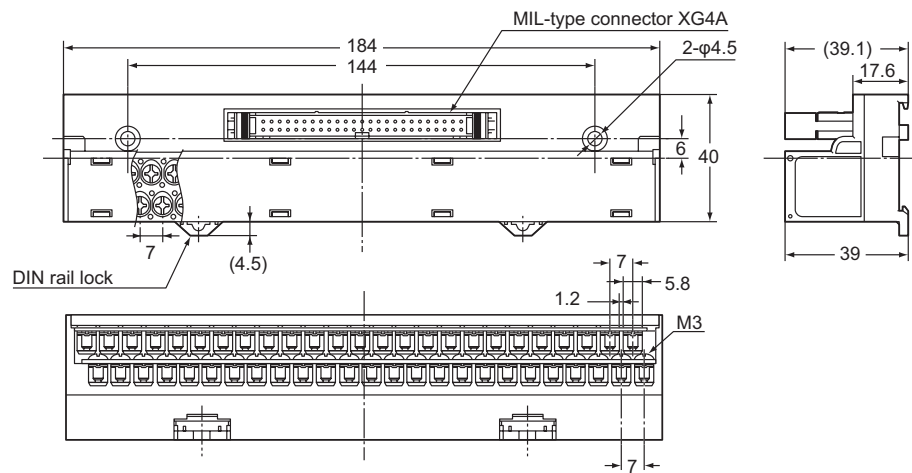

- When using crimp terminals, use crimp terminals with the following dimensions.
- When connecting wires and crimp terminals to a terminal block, tighten them to a torque of 0.7 N·m.

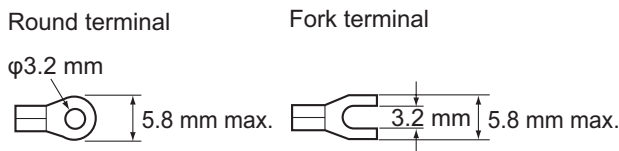

Applicable crimp terminals		Applicable wires
Round terminals	1.25-3	AWG22 to 16 (0.3 to 1.25 mm ²)
Fork terminals	1.25Y-3	AWG22 to 16 (0.3 to 1.25 mm ²)

3-6 Servo Relay Unit and Cable Specifications

This section provides the specifications of the Servo Relay Units and cables for connecting the Servo Drive with various Position Control Units for OMRON Programmable Controllers (SYSMAC). Select a correct relay unit and cable according to the model of your Position Control Unit.

3-6-1 Servo Relay Unit Specifications

XW2B-20J6-1B

Below are the specifications of the Servo Relay Unit for connecting the following OMRON Position Control Unit models.

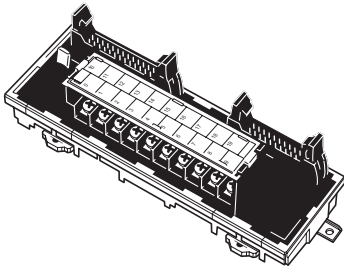

- CJ1W-NC113/-NC133
- CS1W-NC113/-NC133
- C200HW-NC113

● External Dimensions

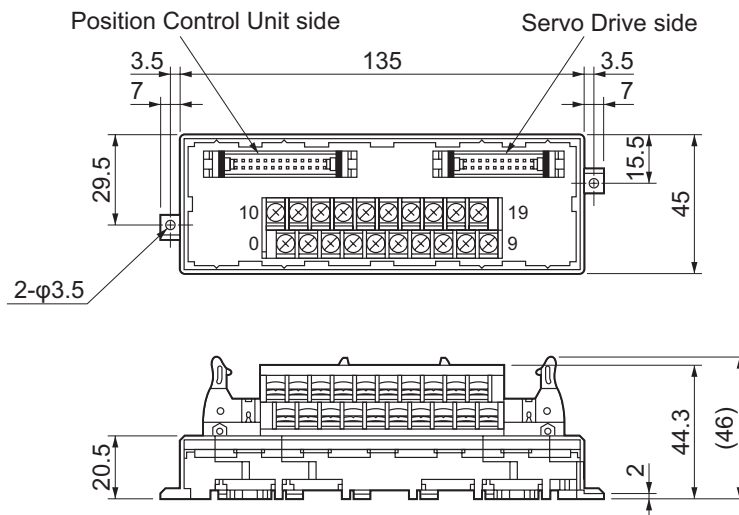

- The pitch of terminals is 7.62 mm.

● Wiring

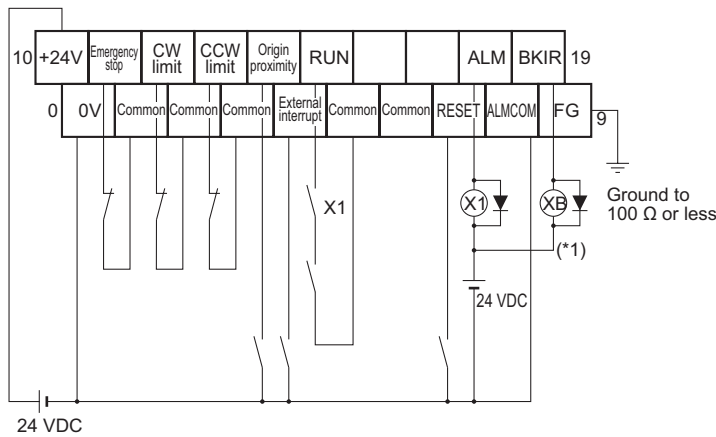

*1 The X1 contact is used to turn ON/OFF the electromagnetic brake.

Note 1 Do not connect wires to unused terminals.

2 0V and common terminals are connected internally.

3 The applicable crimp terminal is R1.25-3 (round or fork type).

XW2B-40J6-2B

Below are the specifications of the Servo Relay Unit for connecting the following OMRON Position Control Unit models.

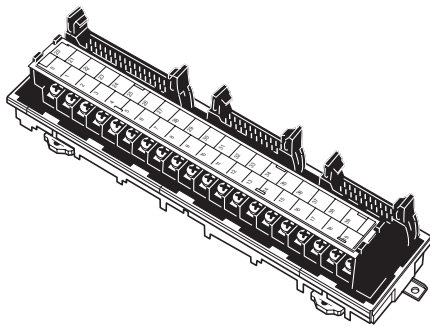

- CJ1W-NC213/-NC233/-NC413/-NC433
- CS1W-NC213/-NC233/-NC413/-NC433
- C200HW-NC213/-NC413

● External Dimensions

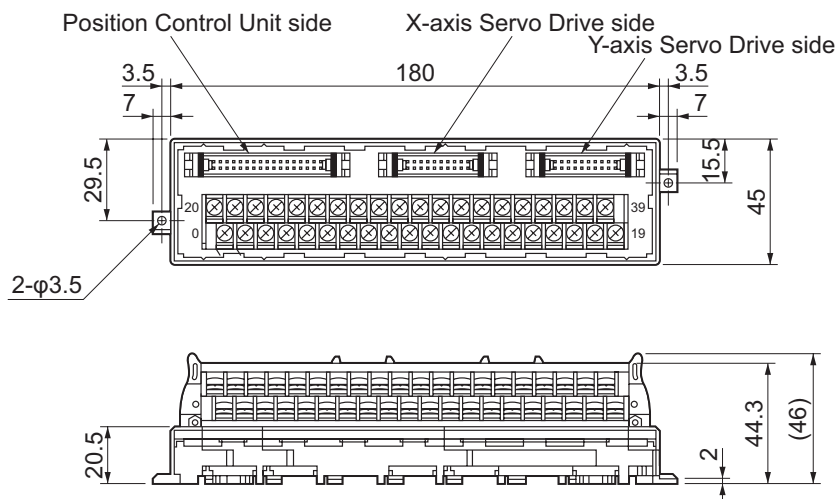

• The pitch of terminals is 7.62 mm.

● Wiring

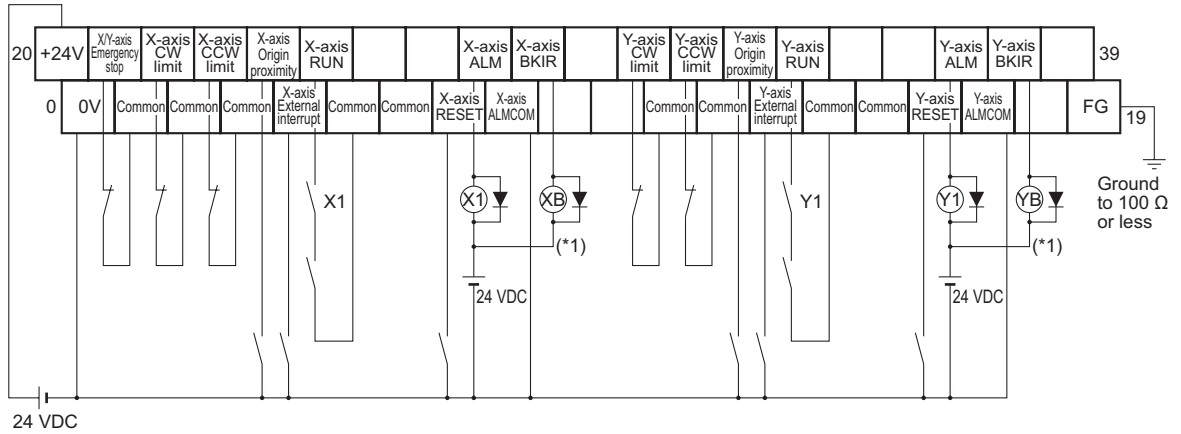

*1 The XB and YB contacts are used to turn ON/OFF the electromagnetic brake.

Note 1 Do not connect wires to unused terminals.

2 0V and common terminals are connected internally.

3 The applicable crimp terminal is R1.25-3 (round or fork type).

XW2B-20J6-3B

Below are the specifications of the Servo Relay Unit for connecting the following OMRON Programmable Controller model.

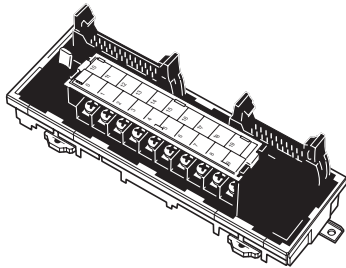

- CQM1-CPU43-V1

● External Dimensions

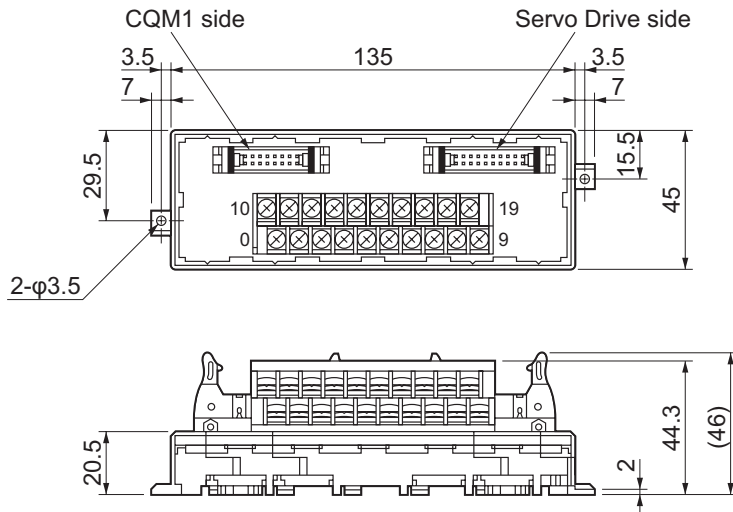

- The pitch of terminals is 7.62 mm.

● Wiring

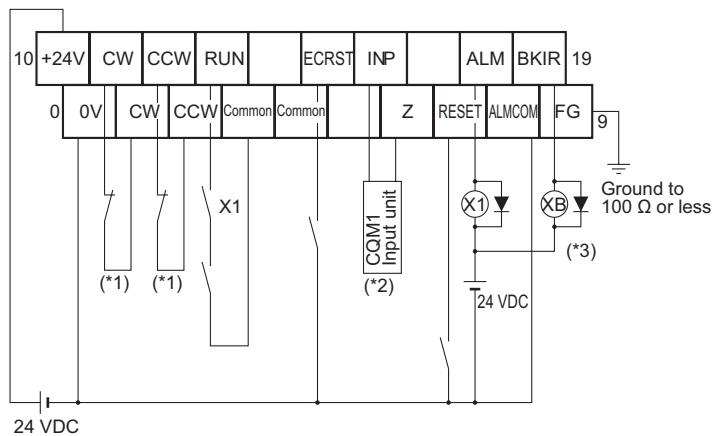

*1 Use this signal to loop-back and input CQM1's output pulses into a high-speed counter.

*2 Input this output signal to CQM1 input unit.

*3 The XB contact is used to turn ON/OFF the electromagnetic brake.

Note 1 Phase Z is an open collector output.

2 Do not connect wires to unused terminals.

3 0V and common terminals are connected internally.

4 The applicable crimp terminal is R1.25-3 (round or fork type).

XW2B-20J6-8A

Below are the specifications of the Servo Relay Unit for connecting the following OMRON Programmable Controller models.

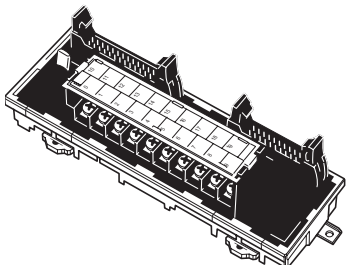

- CJ2M-CPU31/-CPU32/-CPU33/-CPU34/-CPU35 (for 1 axis)
- CJ2M-CPU11/-CPU12/-CPU13/-CPU14/-CPU15 (for 1 axis)

● External Dimensions

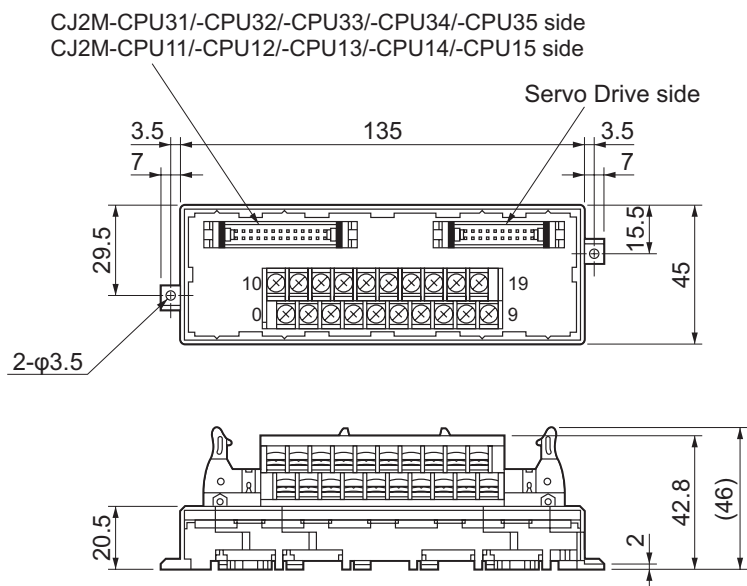

- The pitch of terminals is 7.62 mm.

● **Wiring**

The Servo Drive phase Z output signal is wired to the origin signal in this terminal block.

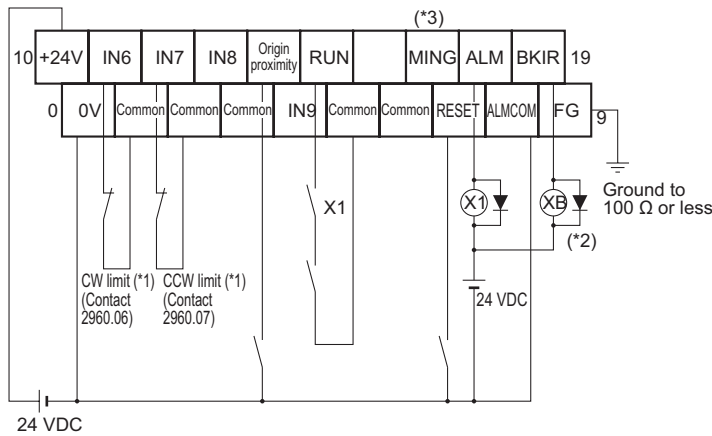

*1 CW and CCW limit input signals can also be input to an input unit. For CJ2M, the CW and CCW limit input signals function with the following signals. CW: A540.08/CCW: A540.09 (Pulse output 0), CW: A541.08/CCW: A541.09 (Pulse output 1) Therefore, in ladder programming, use the actual input as CW and CCW limit input signals to output the following flag.

Example:

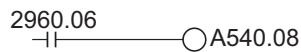

*2 The XB contact is used to turn ON/OFF the electromagnetic brake.

*3 The connection to MING input terminal is disabled.

- Note 1** Do not connect wires to unused terminals.
Note 2 0V and common terminals are connected internally.
Note 3 The applicable crimp terminal is R1.25-3 (round or fork type).

XW2B-40J6-9A

Below are the specifications of the Servo Relay Unit for connecting the following OMRON Programmable Controller models.

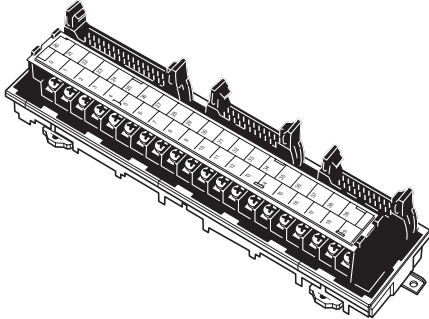

- CJ2M-CPU31/-CPU32/-CPU33/-CPU34/-CPU35 (for 2 axes)
- CJ2M-CPU11/-CPU12/-CPU13/-CPU14/-CPU15 (for 2 axes)

● External Dimensions

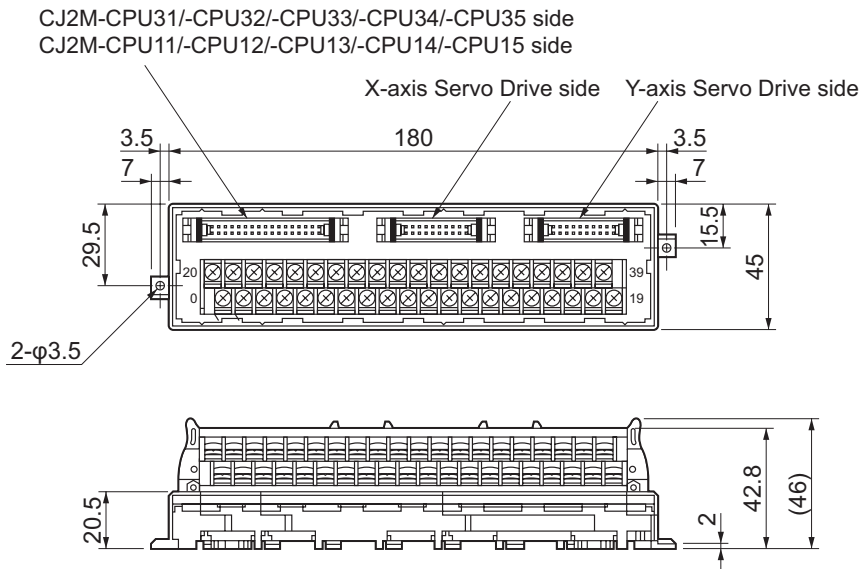

- The pitch of terminals is 7.62 mm.

● **Wiring**

The Servo Drive phase Z output signal is wired to the origin signal in this terminal block.

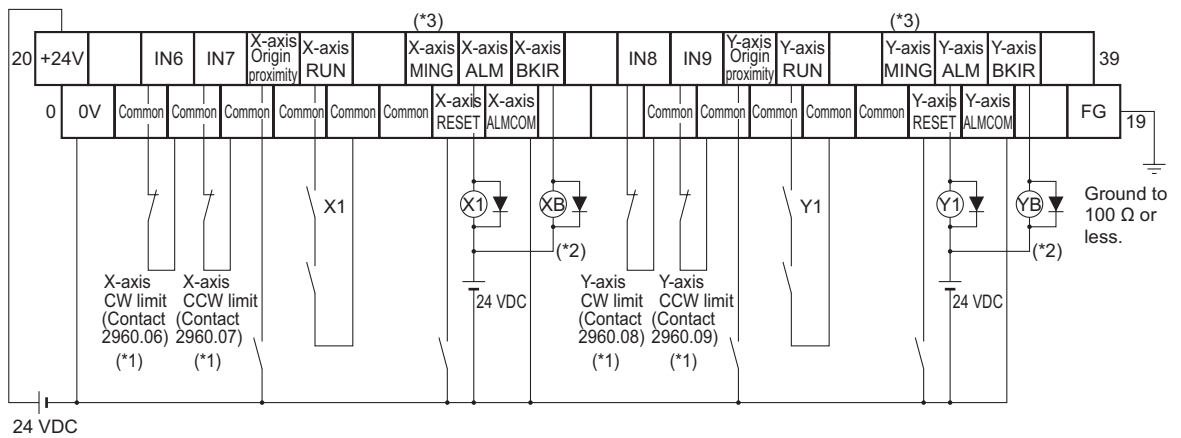

*1 CW and CCW limit input signals can also be input to an input unit. For CJ2M, the CW and CCW limit input signals function with the following signals. CW: A540.08/CCW: A540.09 (Pulse output 0), CW: A541.08/CCW: A541.09 (Pulse output 1) Therefore, in ladder programming, use the actual input as CW and CCW limit input signals to output the following flag.

Example:



*2 The XB and YB contacts are used to turn ON/OFF the electromagnetic brake.

*3 The connection to MING input terminal is disabled.

XW2B-80J7-12A

Below are the specifications of the Servo Relay Unit for connecting the following OMRON controller model.

- FQM1-MMP22

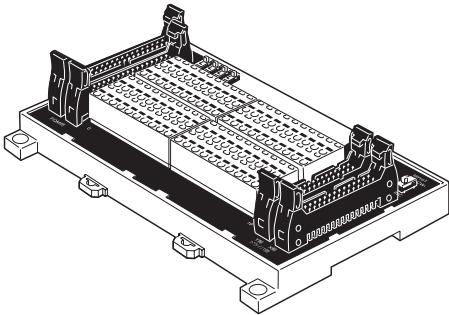

● External Dimensions

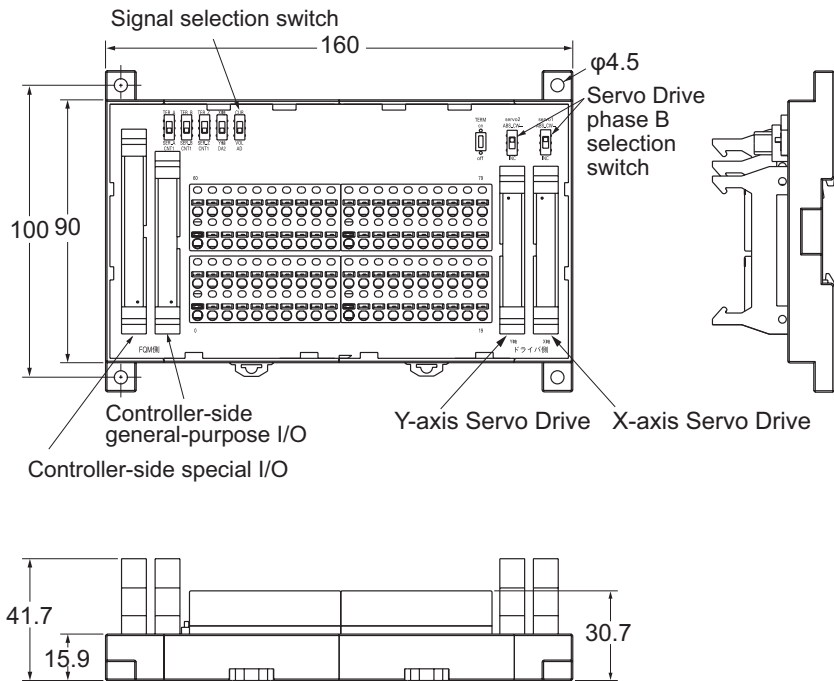

● System Configuration Example (for FQM1)

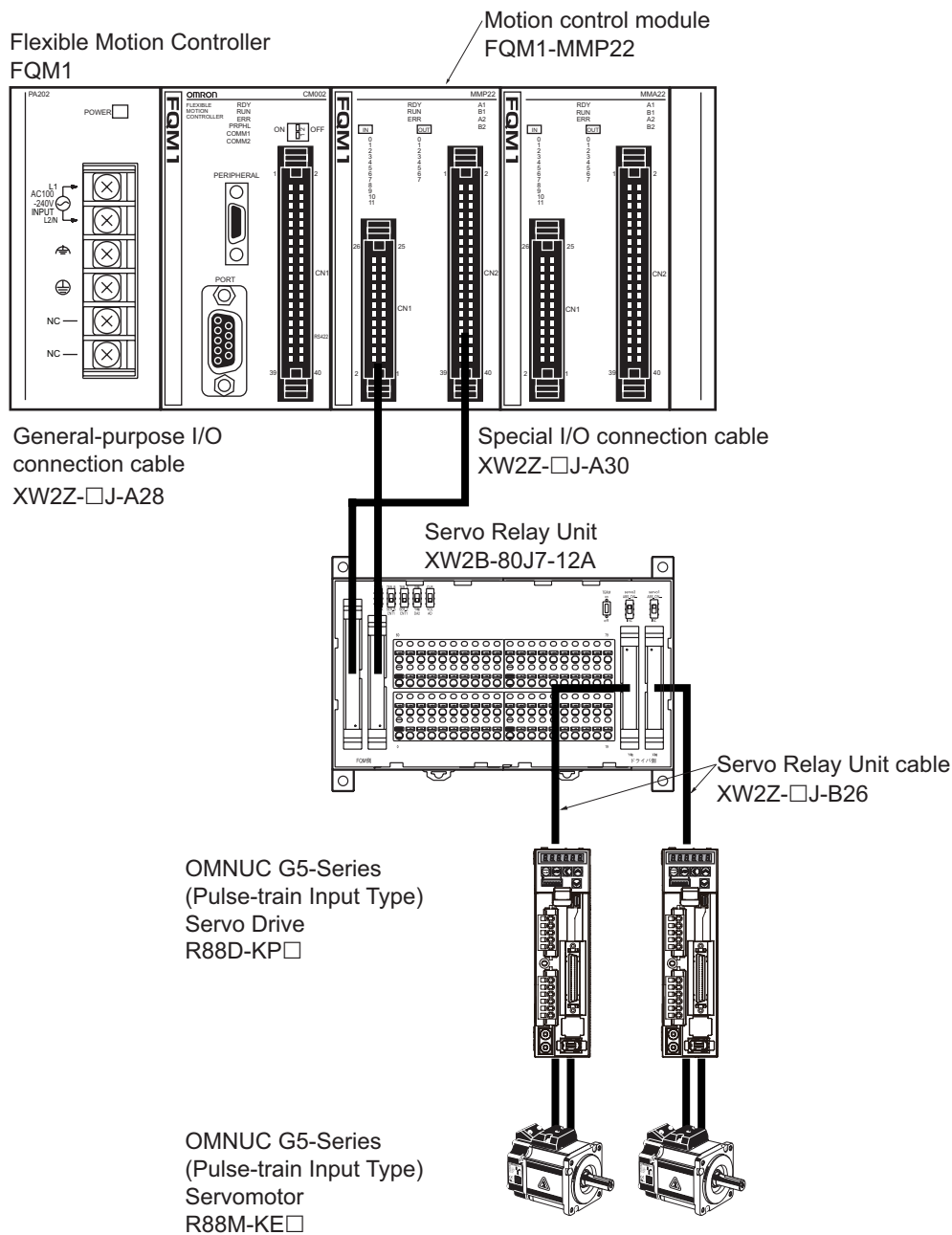

● Terminal Block Connection

- The terminal block signal names vary depending on the Controller to be connected.
- The terminal block has 80 terminals (pins 0 to 79) arranged as shown.
- The following shows the signal names and standard connection wiring schematics.

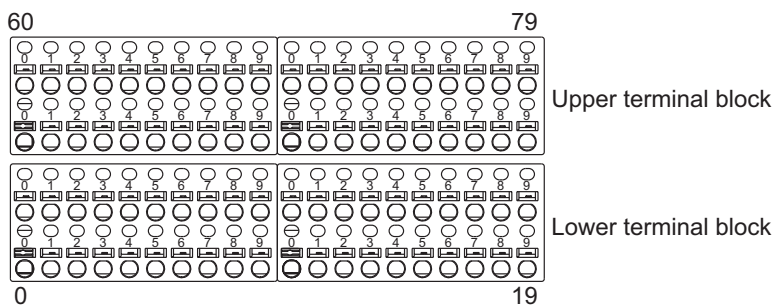

● Signal Allocation for FQM1-MMP22

No.	60	61	62	63	64	65	66	67	68	69	70	71	72	73	74	75	76	77	78	79
Signal	5 V *1	Latch Signal Input 1	Latch Signal Input 2	Servo #1 Phase-A LD +	Servo #1 Phase-B LD +	Servo #1 Phase-Z LD +	-	Servo #1 ALM	Servo #1 BKIR	IN4	IN5	IN6	IN7	-	Servo #1 RUN	Servo #1 RESET	Servo #1 ECRST	Servo #1 GSEL/TLSEL	-	-
No.	40	41	42	43	44	45	46	47	48	49	50	51	52	53	54	55	56	57	58	59
Signal	0 V	Latch Signal 1 Common (0 V)*5	Latch Signal 2 Common (0 V)*5	Servo #1 Phase-A LD -	Servo #1 Phase-B LD -	Servo #1 Phase-Z LD -	-	Servo #1 INP	Common (0 V)*4	IN4 Common (0 V)*4	IN5 Common (0 V)*4	IN6 Common (0 V)*4	IN7 Common (0 V)*4	-	OUT0	OUT1	OUT2	OUT3	-	-

No.	20	21	22	23	24	25	26	27	28	29	30	31	32	33	34	35	36	37	38	39
Signal	+24 V *2	+24 V *3	IN0	IN1	IN2	IN3	-	Servo #2 ALM	Servo #2 BKIR	IN8	IN9	IN10	IN11	-	Servo #2 RUN	Servo #2 RESET	Servo #2 ECRST	Servo #2 GSEL/TLSEL	-	FG
No.	0	1	2	3	4	5	6	7	8	9	10	11	12	13	14	15	16	17	18	19
Signal	0 V	0 V	IN0 Common (0 V)*5	IN1 Common (0 V)*5	IN2 Common (0 V)*5	IN3 Common (0 V)*5	-	Servo #2 INP	Common (0 V)*4	IN8 Common (0 V)*4	IN9 Common (0 V)*4	IN10 Common (0 V)*4	IN11 Common (0 V)*4	-	OUT4	OUT5	OUT6	OUT7	-	FG

- *1 Use as a power supply for FQM1-MMA22 pulse outputs.
- *2 Used as a power supply for IN4 to IN11, OUT0 to OUT7, and servo control signals.
- *3 Used as a power supply for IN0 to IN3 (interrupt input) and latch inputs.
- *4 Connected to pin 0 (0 V).
- *5 Connected to pin 1 (0 V).

● Wiring Example

Servo-side signal			FQM1-side signal			
	#1	#2	For Servo #1		For Servo #2	
RUN	74	34	54	OUT0	14	OUT4
ECRST	76	36	56	OUT2	16	OUT6
INP	47	7	69	IN4	29	IN8
/ALM	67	27	70	IN5	30	IN9
BKIR	68	28	71	IN6	31	IN10

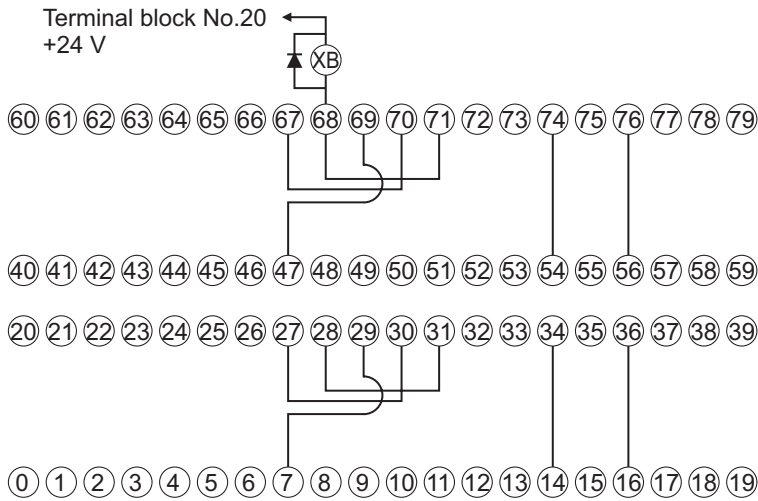

3-6-2 Servo Drive Relay Unit Cable Specifications

Servo Drive Cables (XW2Z-□J-B25)

Below are the specifications of the cable that connects the Servo Drive with a Servo Relay Unit (Model: XW2B-20J6-1B/-3B, XW2B-40J6-2B).

● Cable types

Model	Length (L)	Outer diameter of sheath	Weight
XW2Z-100J-B25	1 m	8.1 dia.	Approx. 0.1 kg
XW2Z-200J-B25	2 m		Approx. 0.2 kg

● Connection configuration and external dimensions

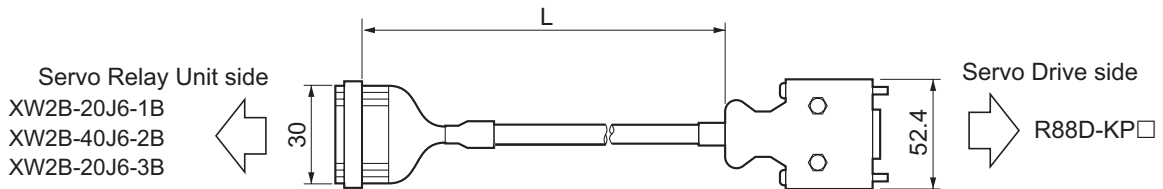

● Wiring

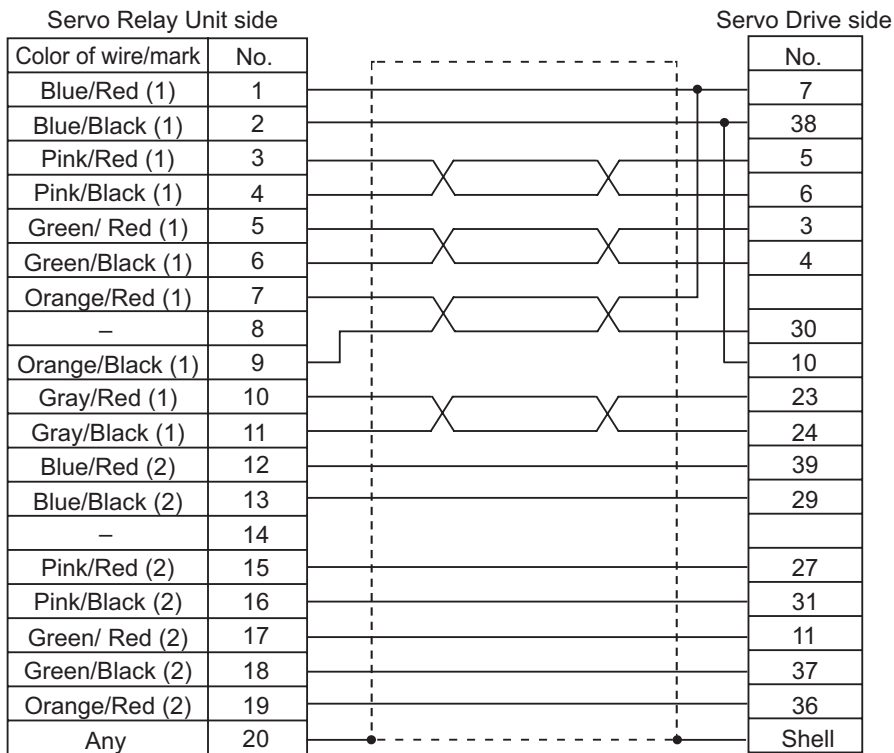

Servo Relay Unit Connector

Connector socket model: XG4M-2030

Strain relief model: XG4T-2004

Cable

AWG28 x 10P UL2464

Drive connector

Connector plug model: 10150-3000PE (Sumitomo 3M)

Connector case model: 10350-52A0-008 (Sumitomo 3M)

Servo Drive Cables (XW2Z-□J-B26)

Below are the specifications of the cable that connects the Servo Drive with a Servo Relay Unit (Model: XW2B-80J7-12A). This cable is used only for FQM1-MMP22.

● Cable types

Model	Length (L)	Outer diameter of sheath	Weight
XW2Z-100J-B26	1 m	9.1 dia.	Approx. 0.1 kg
XW2Z-200J-B26	2 m		Approx. 0.2 kg

● Connection configuration and external dimensions

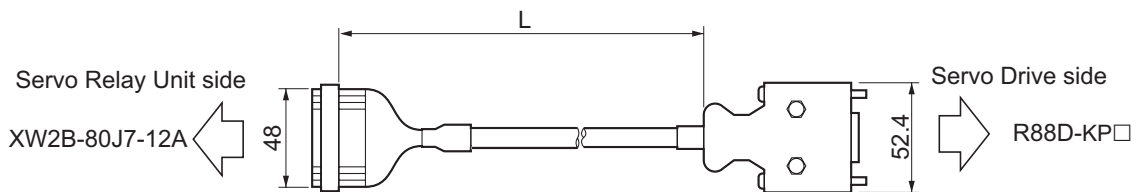

● Wiring

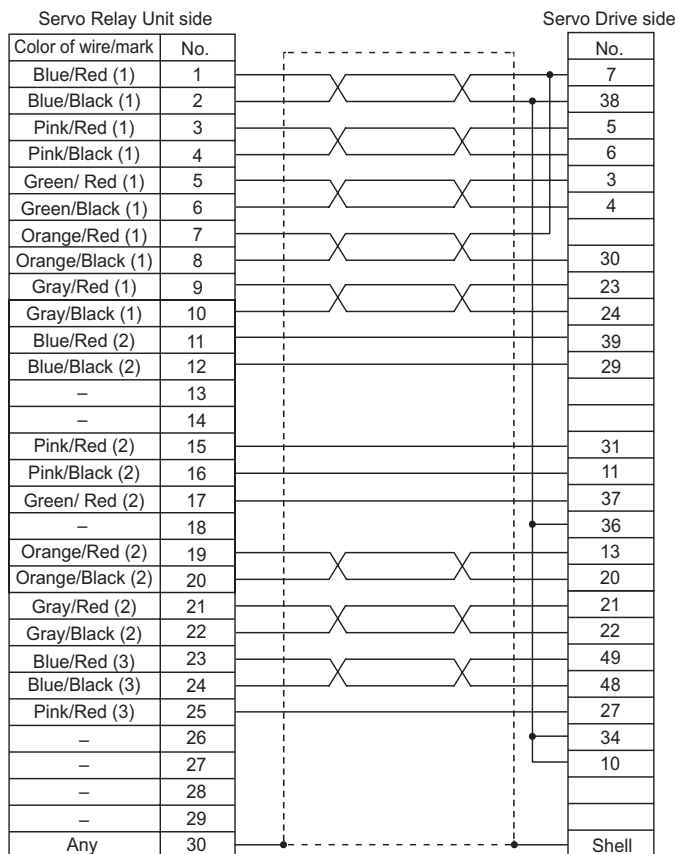

Servo Relay Unit Connector
 Connector socket model: XG4M-3030
 Strain relief model: XG4T-3004

Cable
 AWG28 x 13P UL2464

Drive connector
 Connector plug model: 10150-3000PE (Sumitomo 3M)
 Connector case model: 10350-52A0-008 (Sumitomo 3M)

Servo Drive Cables (XW2Z-□J-B31)

Below are the specifications of the cable that connects the Servo Drive with a Servo Relay Unit (Model: XW2B-20J6-8A, XW2B-40J6-9A).

● Cable types

Model	Length (L)	Outer diameter of sheath	Weight
XW2Z-100J-B31	1 m	8.1 dia.	Approx. 0.1 kg
XW2Z-200J-B31	2 m		Approx. 0.2 kg

● Connection configuration and external dimensions

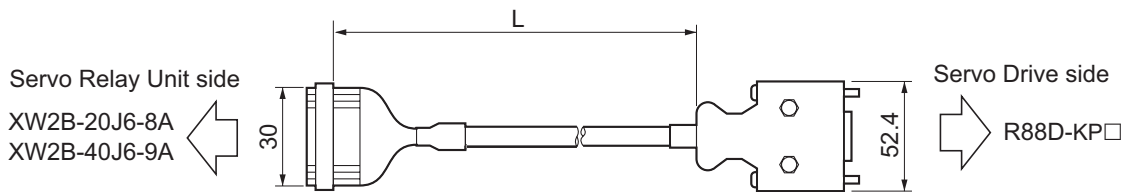

● Wiring

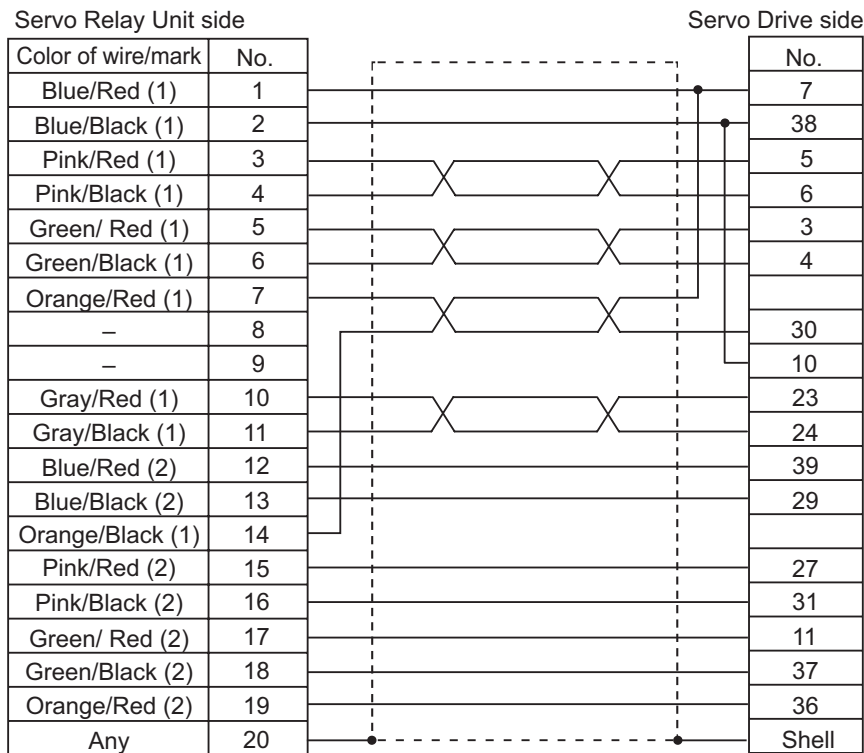

Servo Relay Unit Connector

Connector socket model: XG4M-2030

Strain relief model: XG4T-2004

Cable

AWG28 x 10P UL2464

Drive connector

Connector plug model: 10150-3000PE (Sumitomo 3M)

Connector case model: 10350-52A0-008 (Sumitomo 3M)

3-6-3 Position Control Unit Relay Unit Cable Specifications

Position Control Unit Cables (XW2Z-□J-A6)

Below are the specifications of the cable that connects a Position Control Unit (Model: CS1W-NC113, C200HW-NC113) with a Servo Relay Unit (Model: XW2B-20J6-1B).

● Cable types

Model	Length (L)	Outer diameter of sheath	Weight
XW2Z-050J-A6	50 cm	8.0 dia.	Approx. 0.1 kg
XW2Z-100J-A6	1 m		Approx. 0.1 kg

● Connection configuration and external dimensions

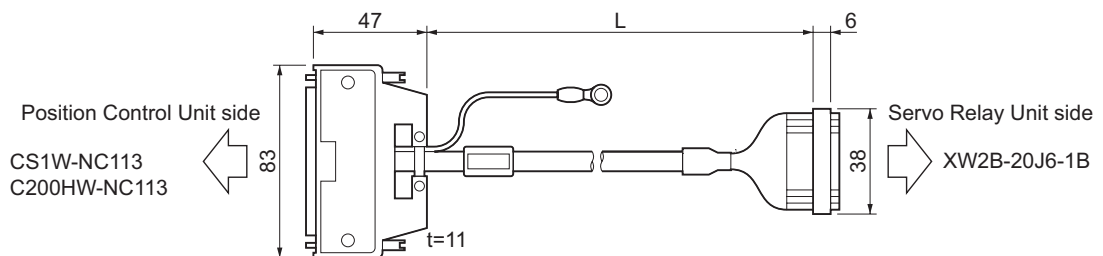

● Wiring

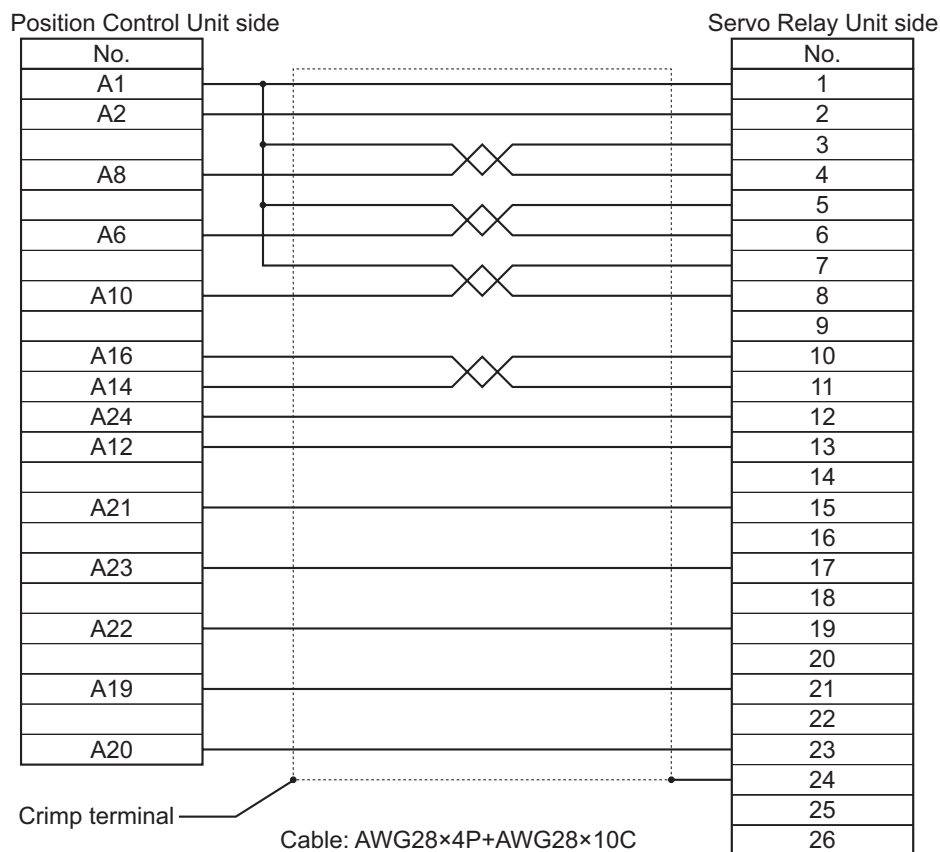

Position Control Unit Cables (XW2Z-□J-A7)

Below are the specifications of the cable that connects a Position Control Unit (Model: CS1W-NC213/413, C200HW-NC213/413) with a Servo Relay Unit (Model: XW2B-40J6-2B).

● Cable types

Model	Length (L)	Outer diameter of sheath	Weight
XW2Z-050J-A7	50 cm	10.0 dia.	Approx. 0.1 kg
XW2Z-100J-A7	1 m		Approx. 0.2 kg

● Connection configuration and external dimensions

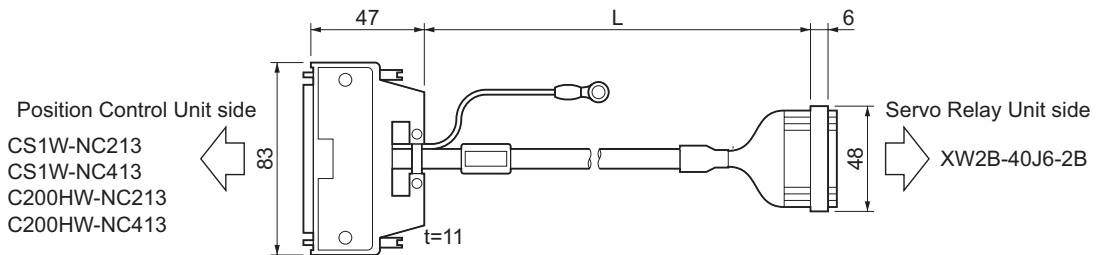

● Wiring

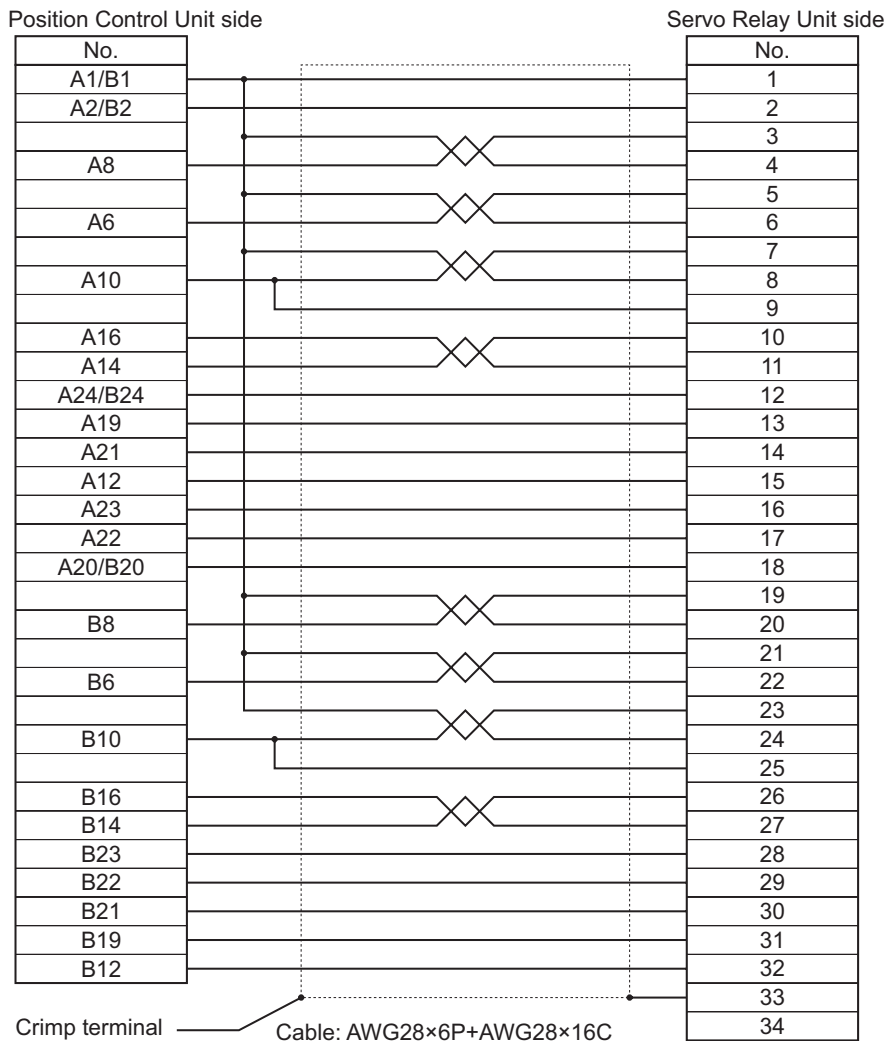

Position Control Unit Cables (XW2Z-□J-A10)

Below are the specifications of the cable that connects a Position Control Unit (Model: CS1W-NC133) with a Servo Relay Unit (Model: XW2B-20J6-1B).

● Cable types

Model	Length (L)	Outer diameter of sheath	Weight
XW2Z-050J-A10	50 cm	10.0 dia.	Approx. 0.1 kg
XW2Z-100J-A10	1 m		Approx. 0.2 kg

● Connection configuration and external dimensions

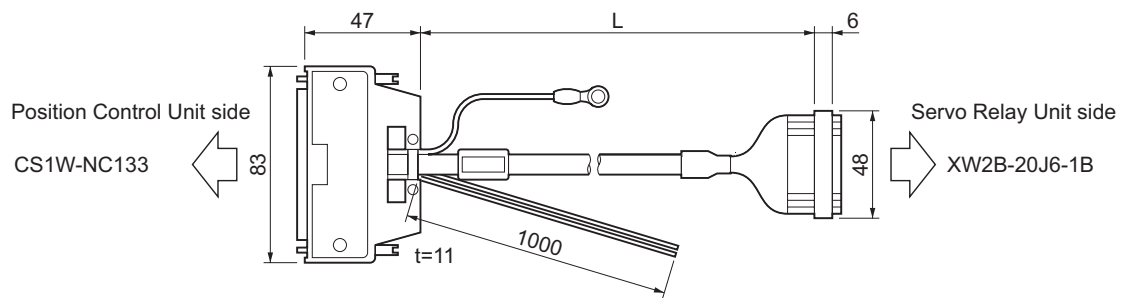

● Wiring

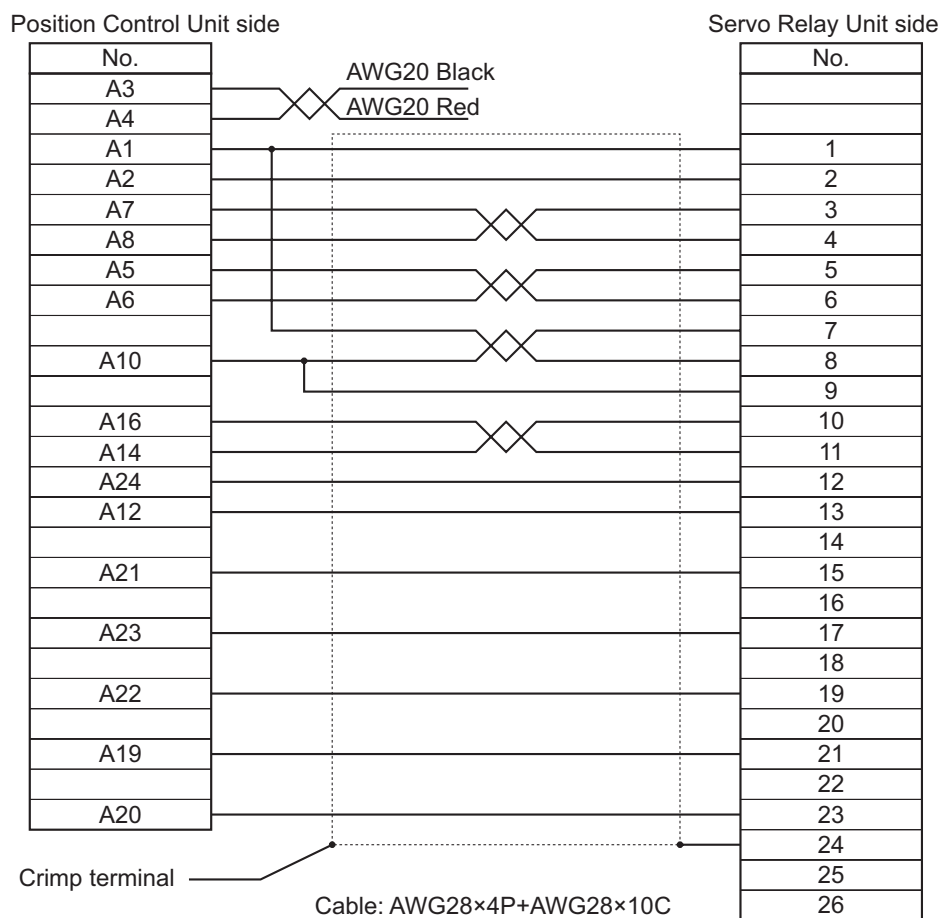

Position Control Unit Cables (XW2Z-□J-A11)

Below are the specifications of the cable that connects a Position Control Unit (Model: CS1W-NC233/433) with a Servo Relay Unit (Model: XW2B-40J6-1B).

● Cable types

Model	Length (L)	Outer diameter of sheath	Weight
XW2Z-050J-A11	50 cm	10.0 dia.	Approx. 0.1 kg
XW2Z-100J-A11	1 m		Approx. 0.2 kg

● Connection configuration and external dimensions

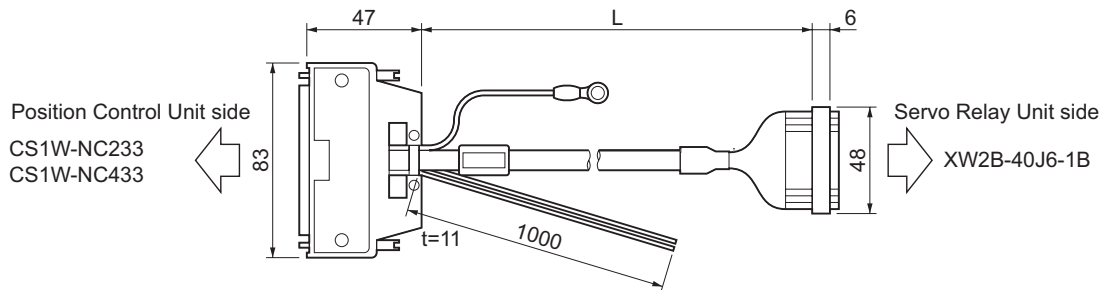

● Wiring

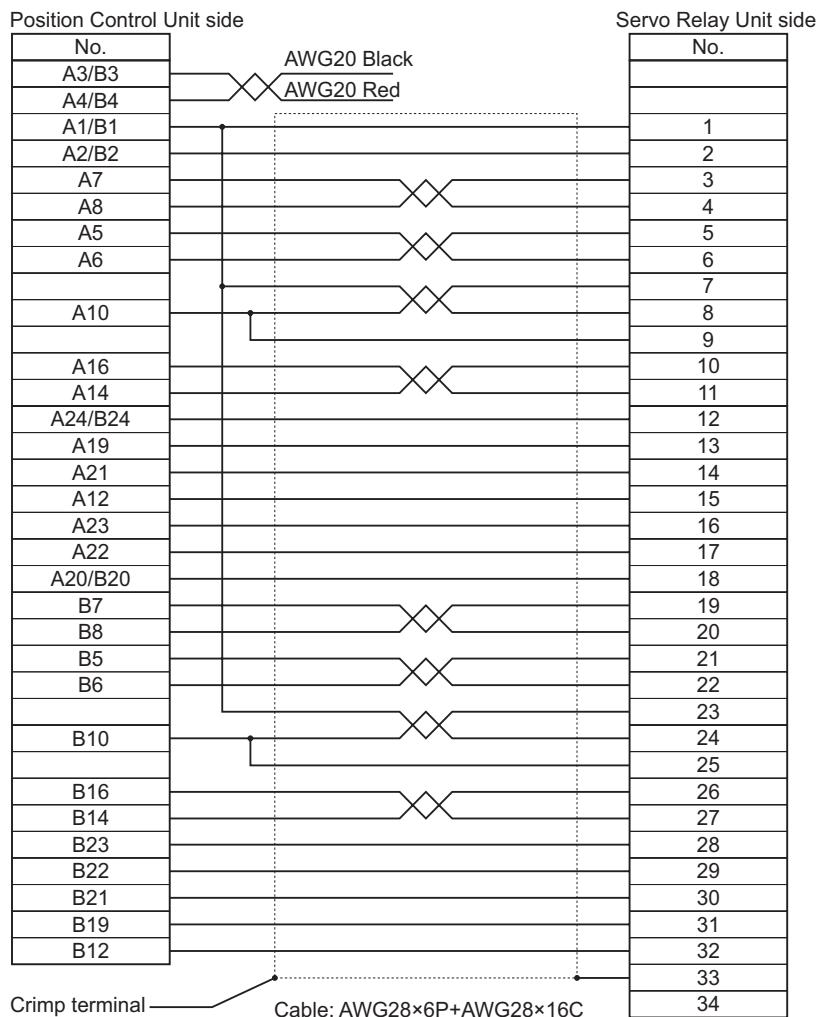

Position Control Unit Cables (XW2Z-□J-A14)

Below are the specifications of the cable that connects a Position Control Unit (Model: CJ1W-NC113) with a Servo Relay Unit (Model: XW2B-20J6-1B).

● Cable types

Model	Length (L)	Outer diameter of sheath	Weight
XW2Z-050J-A14	50 cm	10.0 dia.	Approx. 0.1 kg
XW2Z-100J-A14	1 m		Approx. 0.2 kg

● Connection configuration and external dimensions

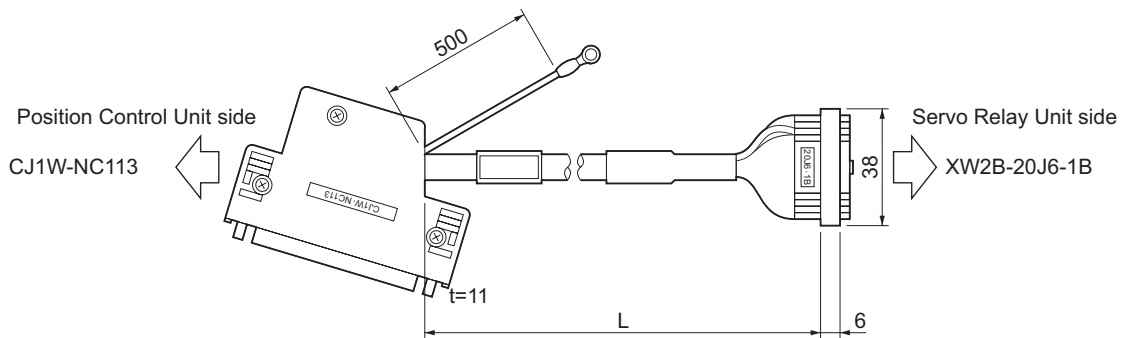

● Wiring

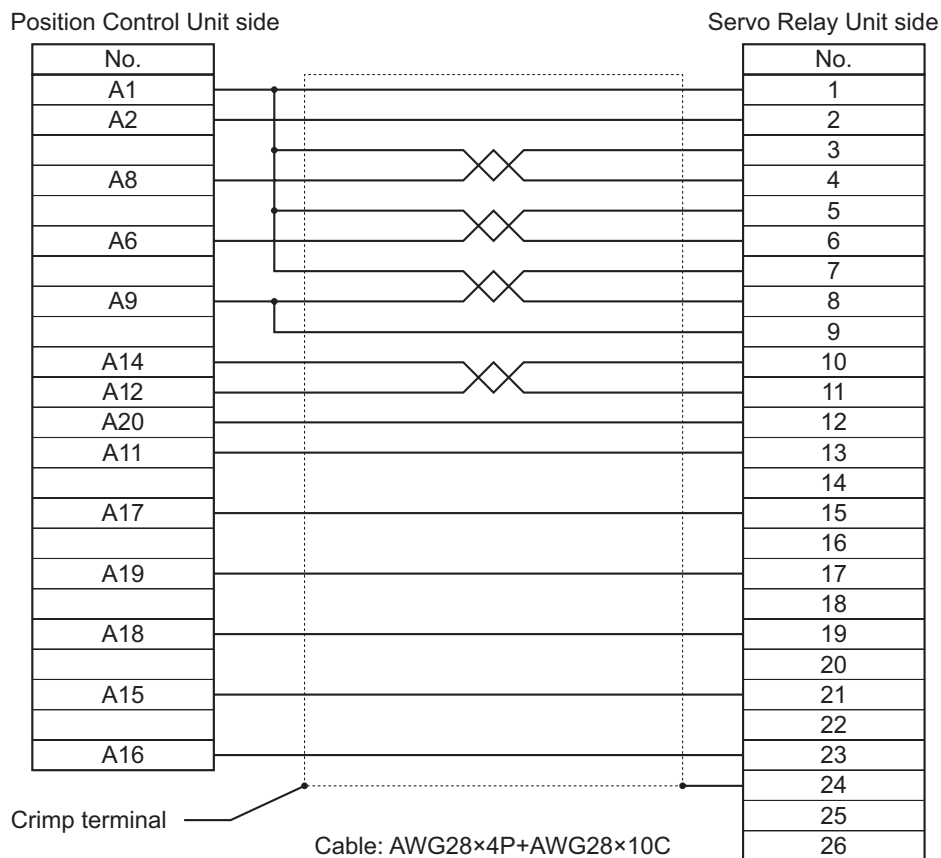

Position Control Unit Cables (XW2Z-□J-A15)

Below are the specifications of the cable that connects a Position Control Unit (Model: CJ1W-NC213/ NC413) with a Servo Relay Unit (Model: XW2B-40J6-2B).

● Cable types

Model	Length (L)	Outer diameter of sheath	Weight
XW2Z-050J-A15	50 cm	10.0 dia.	Approx. 0.1 kg
XW2Z-100J-A15	1 m		Approx. 0.2 kg

● Connection configuration and external dimensions

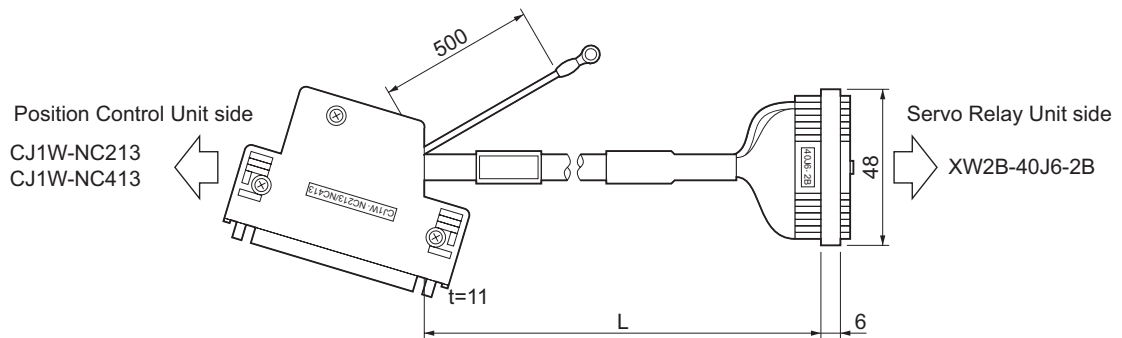

● Wiring

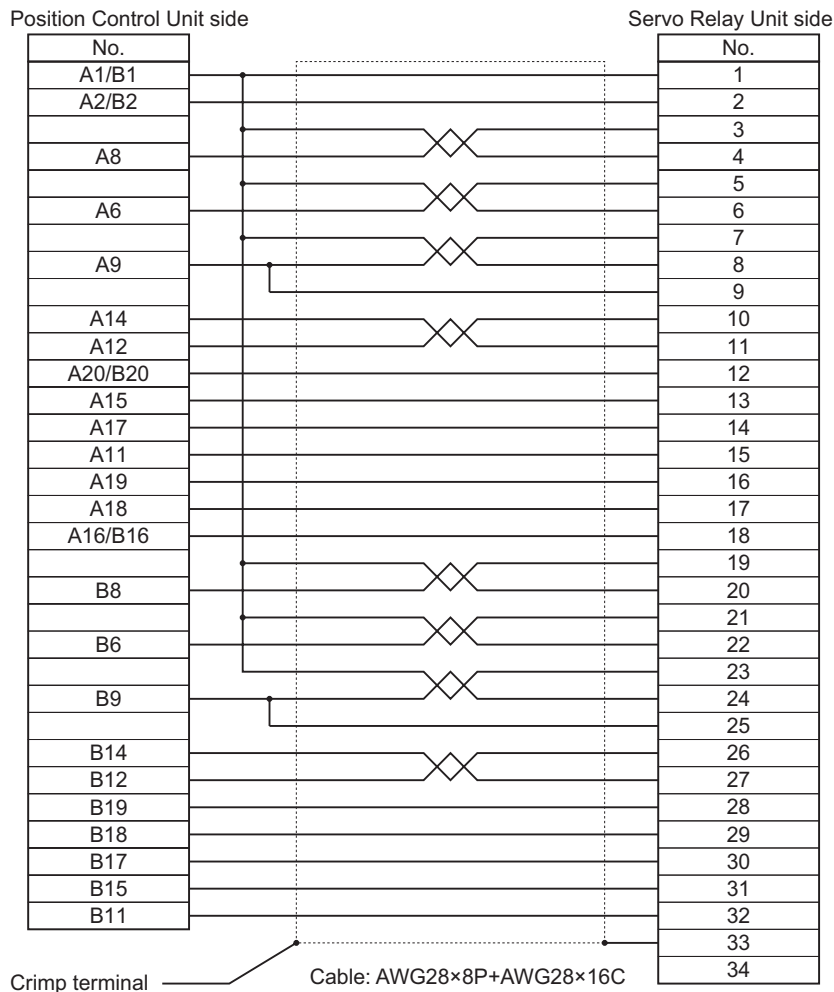

Position Control Unit Cables (XW2Z-□J-A18)

Below are the specifications of the cable that connects a Position Control Unit (Model: CJ1W-NC133) with a Servo Relay Unit (Model: XW2B-20J6-1B).

● Cable types

Model	Length (L)	Outer diameter of sheath	Weight
XW2Z-050J-A18	50 cm	10.0 dia.	Approx. 0.1 kg
XW2Z-100J-A18	1 m		Approx. 0.2 kg

● Connection configuration and external dimensions

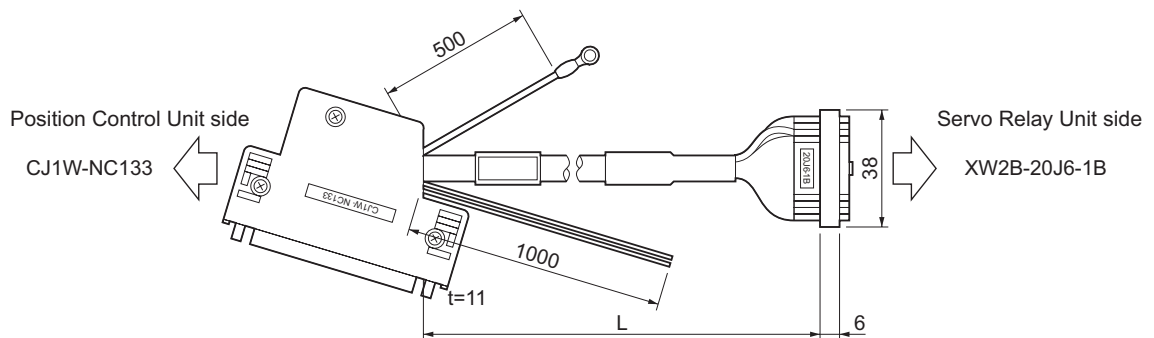

● Wiring

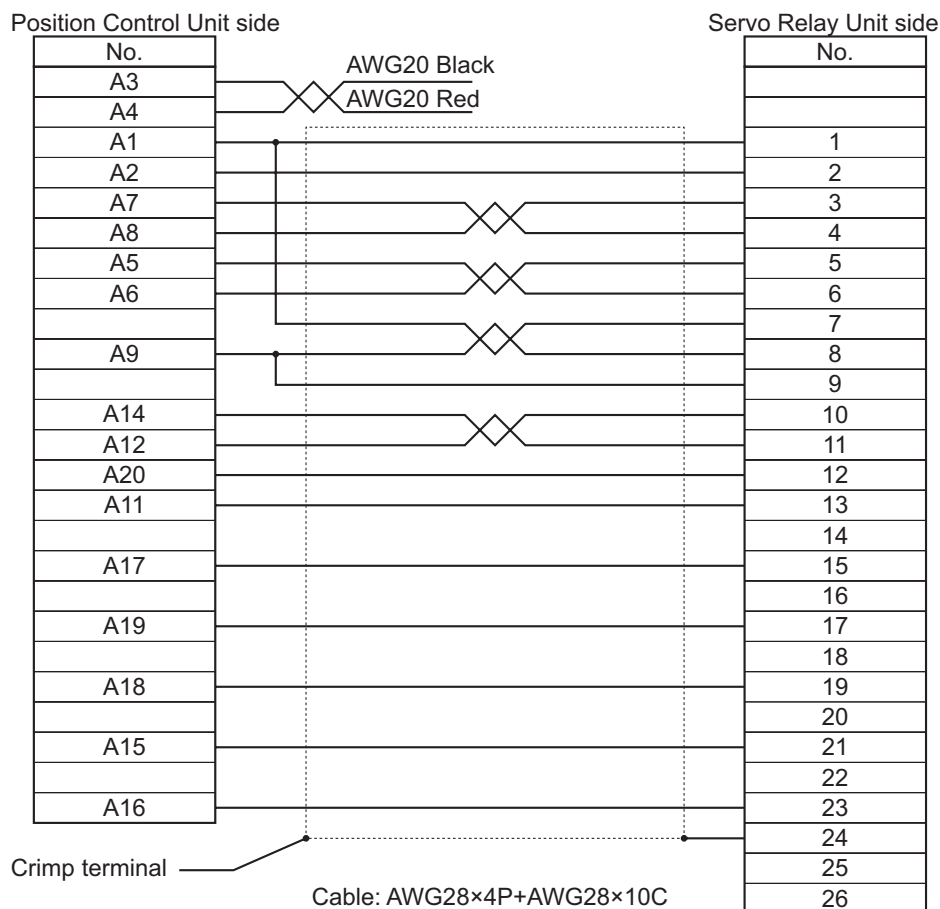

Position Control Unit Cables (XW2Z-□J-A19)

Below are the specifications of the cable that connects a Position Control Unit (Model: CJ1W-NC233/433) with a Servo Relay Unit (Model: XW2B-40J6-2B).

● Cable types

Model	Length (L)	Outer diameter of sheath	Weight
XW2Z-050J-A19	50 cm	10.0 dia.	Approx. 0.1 kg
XW2Z-100J-A19	1 m		Approx. 0.2 kg

● Connection configuration and external dimensions

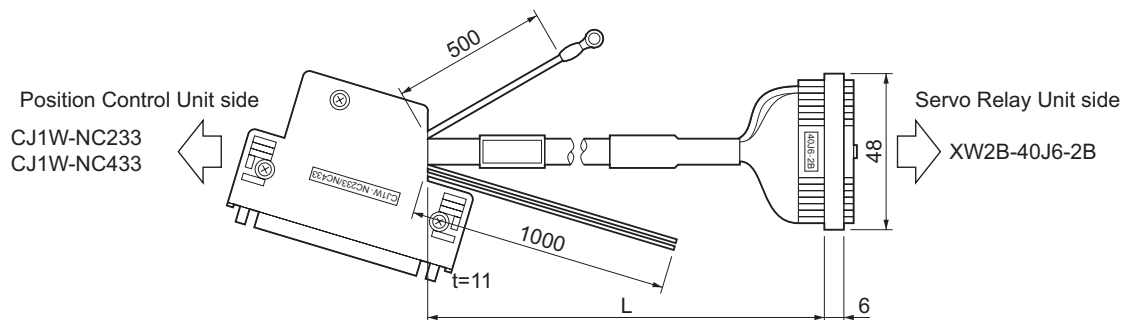

● Wiring

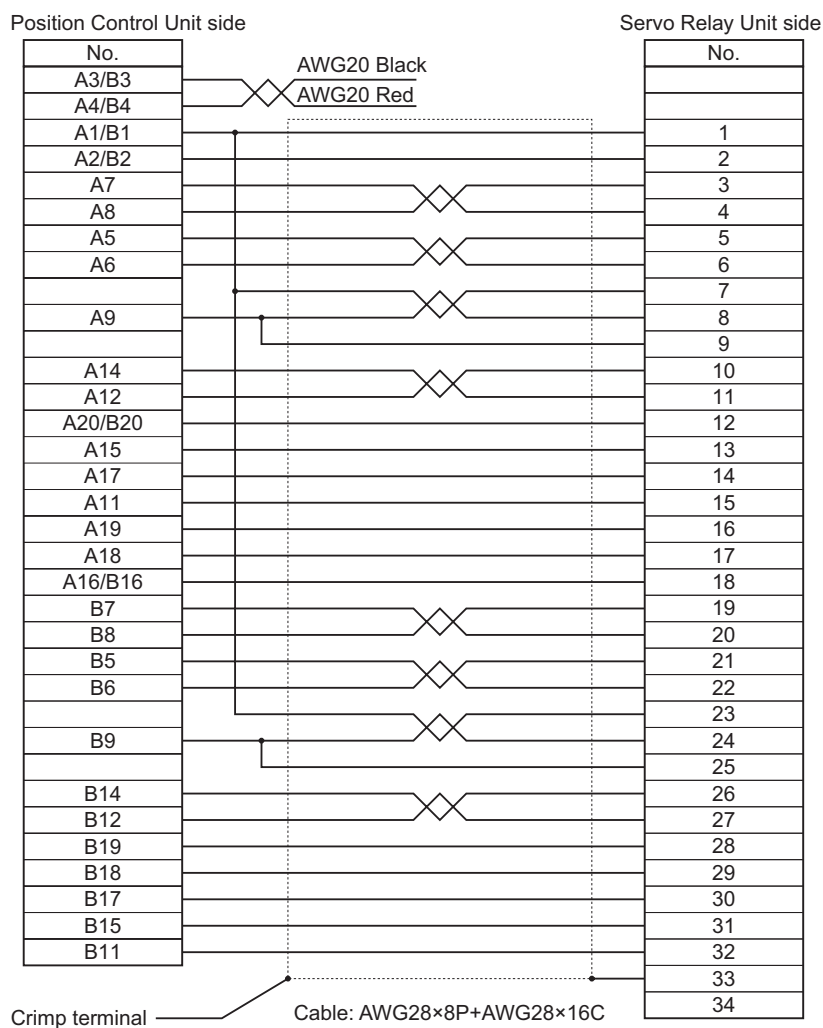

Position Control Unit Cables (XW2Z-□J-A33)

Below are the specifications of the cable that connects a Programmable Controller (Model: CJ2M-CPU31/-CPU32/-CPU33/-CPU34/-CPU35, CJ2M-CPU11/-CPU12/-CPU13/-CPU14/-CPU15) with a Servo Relay Unit (Model: XW2B-20J6-8A, XW2B-40J6-9A).

● Cable types

Model	Length (L)	Outer diameter of sheath	Weight
XW2Z-050J-A33	50 cm	10.0 dia.	Approx. 0.1 kg
XW2Z-100J-A33	1 m		Approx. 0.2 kg

● Connection configuration and external dimensions

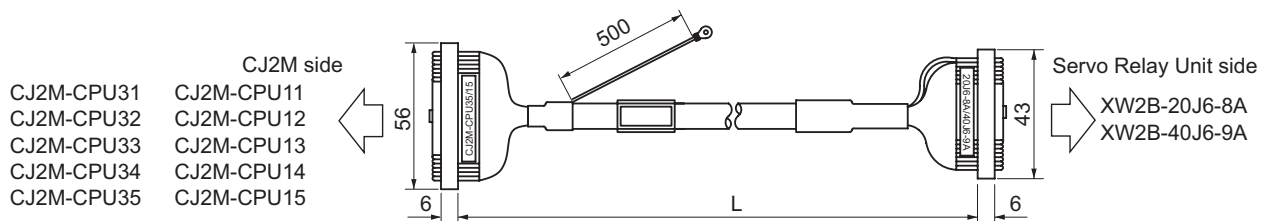

● Wiring

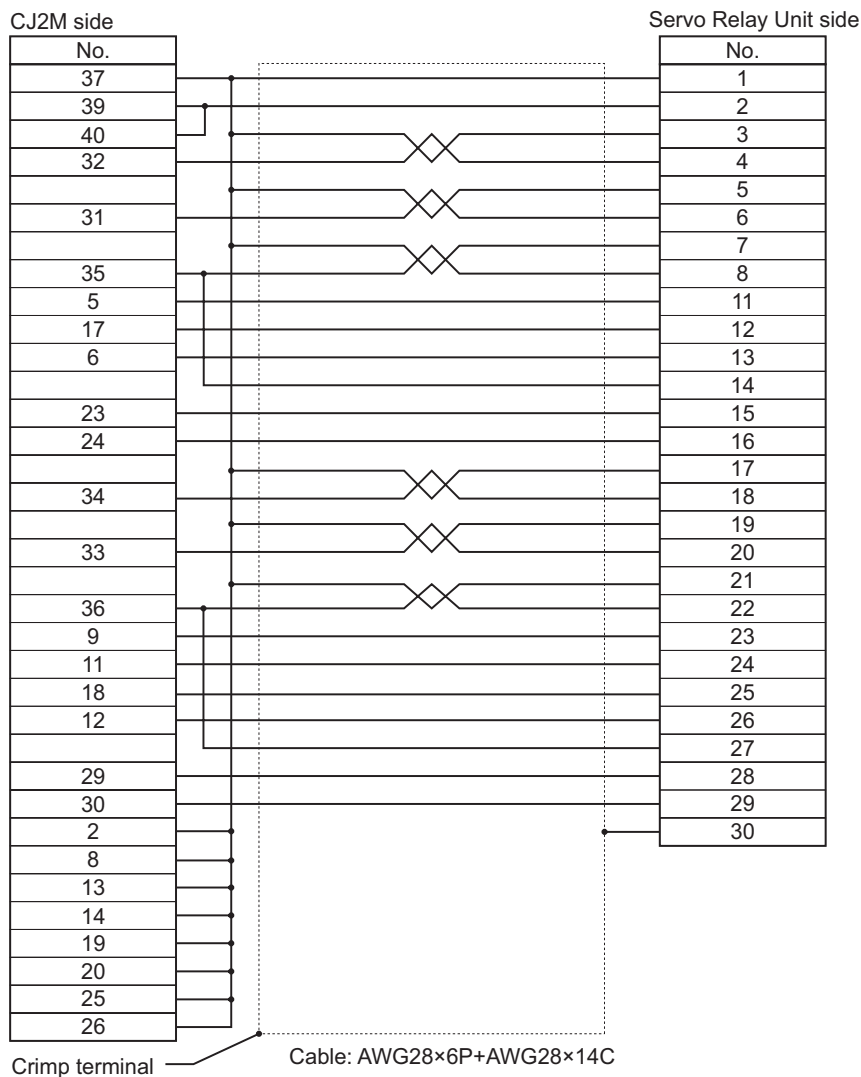

Position Control Unit Cables (XW2Z-□J-A28)

Below are the specifications of the cable that connects the general-purpose I/O connector for the Flexible Motion Controller (Model: FQM1-MMP22) with a Servo Relay Unit (Model: XW2B-80J7-12A).

● Cable types

Model	Length (L)	Outer diameter of sheath	Weight
XW2Z-050J-A28	50 cm	10.0 dia.	Approx. 0.1 kg
XW2Z-100J-A28	1 m		Approx. 0.2 kg
XW2Z-200J-A28	2 m		Approx. 0.3 kg

● Connection configuration and external dimensions

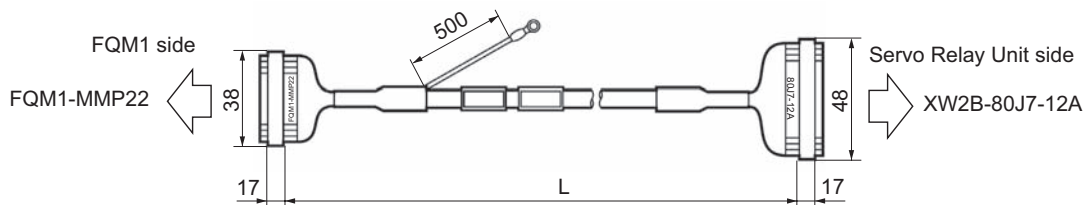

● Wiring

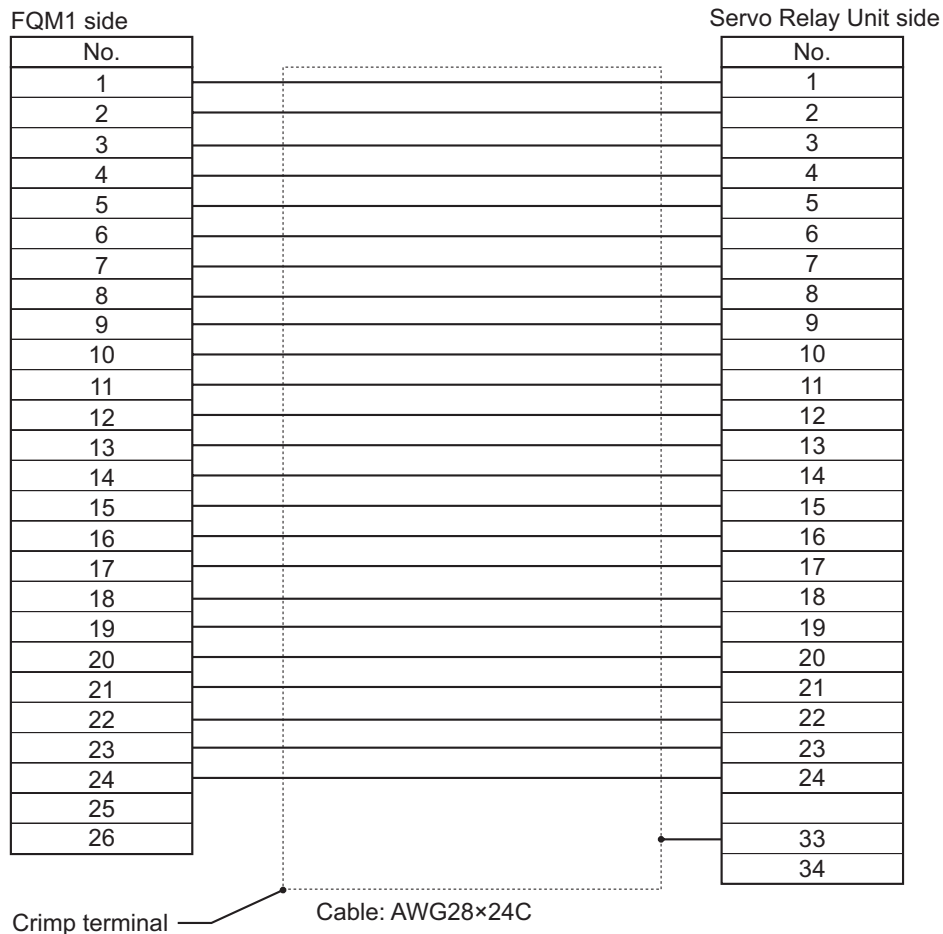

Position Control Unit Cables (XW2Z-□J-A30)

Below are the specifications of the cable that connects the special I/O connector for the Flexible Motion Controller (Model: FQM1-MMP22) with a Servo Relay Unit (Model: XW2B-80J7-12A).

● Cable types

Model	Length (L)	Outer diameter of sheath	Weight
XW2Z-050J-A30	50 cm	10.0 dia.	Approx. 0.1 kg
XW2Z-100J-A30	1 m		Approx. 0.2 kg
XW2Z-200J-A30	2 m		Approx. 0.3 kg

● Connection configuration and external dimensions

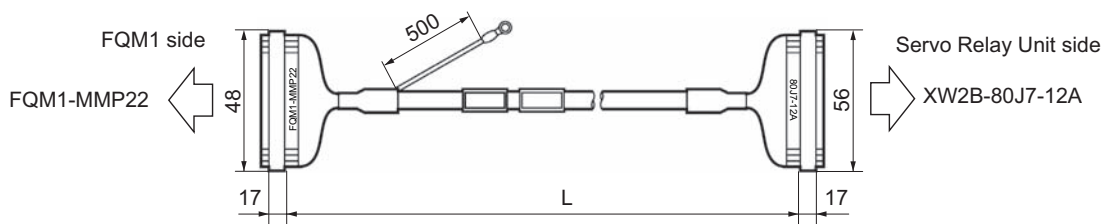

● Wiring

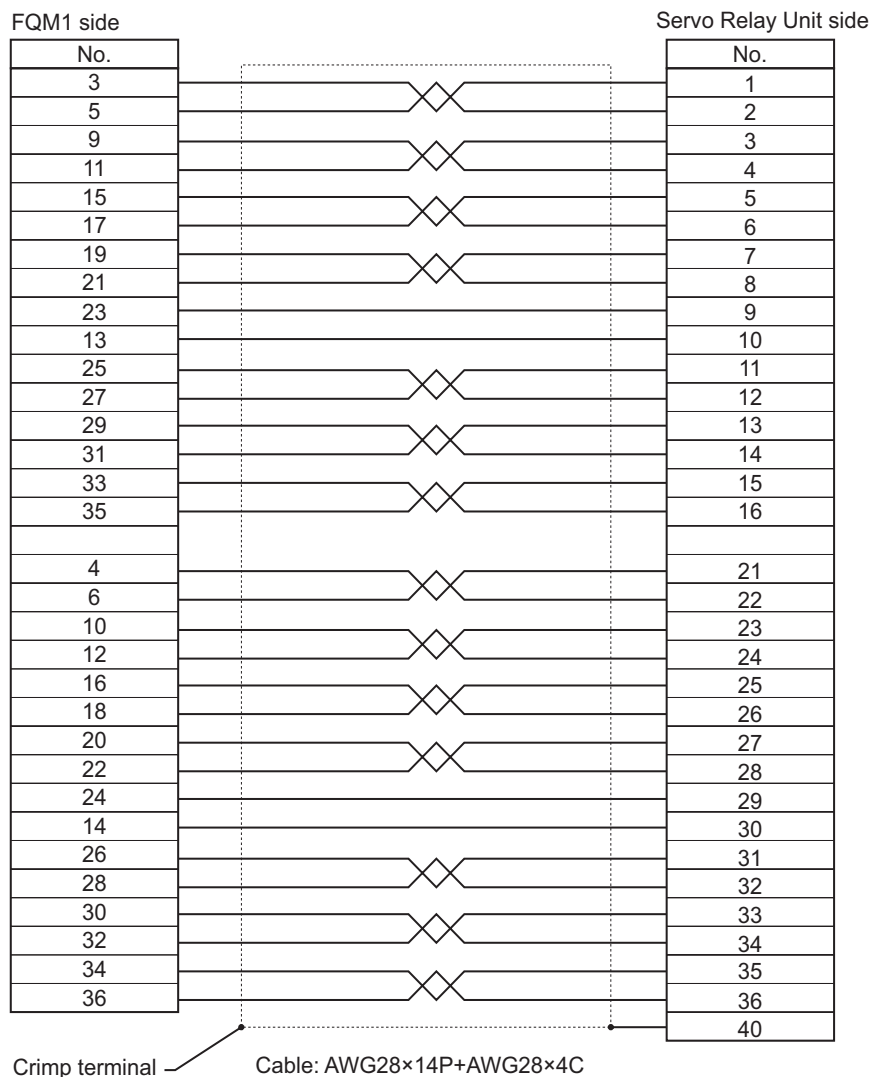

3-7 External Regeneration Resistor Specifications

3-7-1 External Regeneration Resistor Specifications

R88A-RR08050S

Model	Resistance value	Nominal capacity	Regeneration absorption for 120°C temperature rise	Heat radiation condition	Thermal switch output specifications
R88A-RR08050S	50 Ω	80 W	20 W	Aluminum 350 x 350, Thickness: 3.0	Operating temperature: 150°C ± 5°C NC contact Rated output (resistive load) 125 VAC, 0.1 A max. 30 VDC, 0.1 A max. (minimum current: 1 mA)

R88A-RR080100S

Model	Resistance value	Nominal capacity	Regeneration absorption for 120°C temperature rise	Heat radiation condition	Thermal switch output specifications
R88A-RR080100S	100 Ω	80 W	20 W	Aluminum 350 x 350, Thickness: 3.0	Operating temperature: 150°C ± 5°C NC contact Rated output (resistive load) 125 VAC, 0.1 A max. 30 VDC, 0.1 A max. (minimum current: 1 mA)

R88A-RR22047S

Model	Resistance value	Nominal capacity	Regeneration absorption for 120°C temperature rise	Heat radiation condition	Thermal switch output specifications
R88A-RR22047S	47 Ω	220 W	70 W	Aluminum 350 x 350, Thickness: 3.0	Operating temperature: 170°C ± 7°C NC contact Rated output (resistive load): 250 VAC, 3 A max.

R88A-RR22047S1

Model	Resistance value	Nominal capacity	Regeneration absorption for 120°C temperature rise	Heat radiation condition	Thermal switch output specifications
R88A-RR22047S1	47 Ω	220 W	70 W	Aluminum 350 x 350, Thickness: 3.0	Operating temperature: 150°C ± 5°C NC contact Rated output (resistive load) 250 VAC, 0.2 A max. 42 VDC, 0.2 A max. (minimum current: 1 mA)

R88A-RR50020S

Model	Resistance value	Nominal capacity	Regeneration absorption for 120°C temperature rise	Heat radiation condition	Thermal switch output specifications
R88A-RR50020S	20 Ω	500 W	180 W	Aluminum 600 x 600, Thickness: 3.0	Operating temperature: 200°C ± 7°C NC contact Rated output (resistive load) 250 VAC, 0.2 A max. 42 VDC, 0.2 A max.

3-8 Reactor Specifications

Connect a Reactor to the Servo Drive for reduction of harmonic current. Select an appropriate Reactor according to the Servo Drive model.

Specifications

Servo Drive model	Reactor				
	Model	Rated current	Inductance	Weight	Reactor type
R88D-KP01H (For single-phase input)	3G3AX-DL2002	1.6 A	21.4 mH	Approx. 0.8 kg	DC reactor
R88D-KP02H (For single-phase input)	3G3AX-DL2004	3.2 A	10.7 mH	Approx. 1.0 kg	
R88D-KP04H (For single-phase input)	3G3AX-DL2007	6.1 A	6.75 mH	Approx. 1.3 kg	
R88D-KP08H R88D-KP10H (For single-phase input)	3G3AX-DL2015	9.3 A	3.51 mH	Approx. 1.6 kg	
R88D-KP15H (For single-phase input)	3G3AX-DL2022	13.8 A	2.51 mH	Approx. 2.1 kg	
R88D-KP01H R88D-KP02H R88D-KP04H R88D-KP08H R88D-KP10H R88D-KP15H (For 3-phase input)	3G3AX-AL2025	10.0 A	2.8 mH	Approx. 2.8 kg	AC reactor
R88D-KP20H R88D-KP30H	3G3AX-AL2055	20.0 A	0.88 mH	Approx. 4.0 kg	
R88D-KP50H	3G3AX-AL2110	34.0 A	0.35 mH	Approx. 5.0 kg	

4

System Design

This section explains the installation conditions, wiring methods which include wiring conforming to EMC directives, and regenerative energy calculation methods for the Servo Drives, Servomotors, and Decelerators. It also explains the performance of External Regeneration Resistors.

4

4-1	Installation Conditions	4-2
4-1-1	Servo Drive Installation Conditions	4-2
4-1-2	Servomotor Installation Conditions	4-3
4-1-3	Decelerator Installation Conditions	4-6
4-2	Wiring	4-10
4-2-1	Peripheral Equipment Connection Examples	4-10
4-2-2	Main Circuit and Motor Connections	4-14
4-3	Wiring Conforming to EMC Directives	4-20
4-3-1	Wiring Method	4-20
4-3-2	Selecting Connection Components	4-26
4-4	Regenerative Energy Absorption	4-39
4-4-1	Calculating the Regenerative Energy	4-39
4-4-2	Servo Drive Regeneration Absorption Capacity	4-41
4-4-3	Regenerative Energy Absorption with an External Regeneration Resistor ..	4-42
4-4-4	Connecting an External Regeneration Resistor	4-43

4-1 Installation Conditions

4-1-1 Servo Drive Installation Conditions

Space Conditions around Servo Drives

- Install the Servo Drives according to the dimensions shown in the following illustration to ensure proper dispersion of heat from inside the drives and convection inside the panel. If the drives are installed side by side, install a fan for air circulation to prevent uneven temperatures inside the panel.

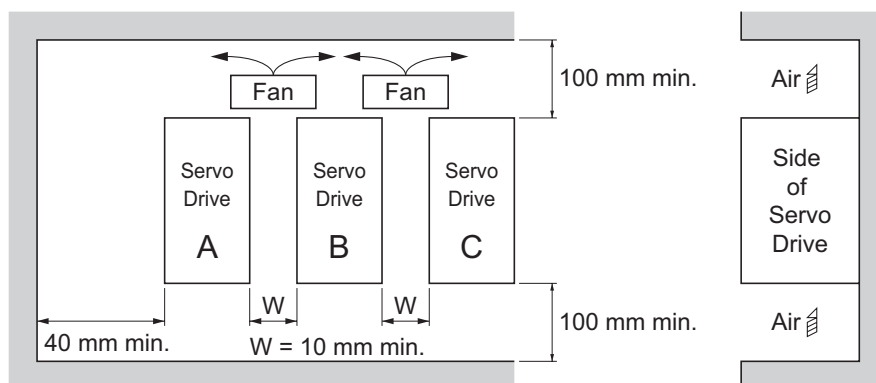

- If the mounting surface of the Servo Drive is coated, remove the coating to allow electrical conduction. If you make your own mounting bracket, we recommend that you apply electrically conductive plating.

Mounting Direction

- Mount the Servo Drive perpendicular on the panel so that the model number reads normally.

Operating Environment Conditions

- The environment in which drives are operated must meet the following conditions. Drives may malfunction if operated under any other conditions.

Operating ambient temperature: 0 to 50°C (Take into account that the temperature rises in the following individual drives themselves.)

Operating ambient humidity: 90% max. (with no condensation)

Operating ambient atmosphere: No corrosive gases.

Altitude: 1,000 m max.

- Drives of 200 V with a capacity of 750 W max. can be installed side by side with a 1 mm clearance (W in above illustration). The ambient temperature condition depends on the Servo Drive A, B, or C.

Servo Drive A: 0 to 50°C

Servo Drive B: 0 to 40°C

Servo Drive C: 0 to 45°C

Ambient Temperature Control

- Operation in an environment in which there is minimal temperature rise is recommended to maintain a high level of reliability.
- When the drive is installed in a closed space, such as a box, the ambient temperature may rise due to temperature rise in each unit. Use a fan or air conditioner to prevent the drive's ambient temperature from exceeding 50°C.
- Drive surface temperature may rise to as much as 30°C above the ambient temperature. Use heat-resistant materials for wiring, and provide a distance from any devices or wiring that are sensitive to heat.
- The service life of a Servo Drive is largely determined by the ambient temperature around the internal electrolytic capacitors. When an electrolytic capacitor reaches its limit, electrostatic capacity drops and internal resistance increases. This leads to overvoltage alarms, malfunctioning due to noise, and damage to individual elements.
- If a drive is always operated at the ambient temperature of 50°C and with a 100% output of the rated torque and rated rotation speed, its life is expected to be approx. 28,000 hours (excluding the axial-flow fan). A drop of 10°C in the ambient temperature will double the expected life of the drive.

Keeping Foreign Objects Out of Units

- Place a cover over the drive or take other preventative measures to prevent foreign objects, such as drill filings, from getting into the drive during installation. Be sure to remove the cover after installation is complete. If the cover is left on during operation, drive's heat dissipation is blocked, which may result in malfunction.
- Take measures during installation and operation to prevent foreign objects such as metal particles, oil, machining oil, dust, or water from getting inside of the drives.

4-1-2 Servomotor Installation Conditions

Operating Environment Conditions

- The environment in which the motor is operated must meet the following conditions. Operating the motor outside of the following ranges may result in malfunction of the motor.

Operating ambient temperature: 0 to 40°C*¹

Operating ambient humidity: 85% max. (with no condensation)

Operating ambient atmosphere: No corrosive gases.

*1 The operating ambient temperature is the temperature at a point 5 cm from the motor.

Impact and Load

- The motor is resistant to impacts of up to 98 m/s². Do not apply heavy impacts or loads during transport, installation, or removal of the motor.
- When transporting the motor, hold the motor body itself. And do not hold the encoder, cable, or connector areas. Failure to follow this guideline may result in damaging the motor.
- Always use a pulley remover to remove pulleys, couplings, or other objects from the shaft.
- After assembly, secure cables so that there is no impact or load placed on the cable outlet.

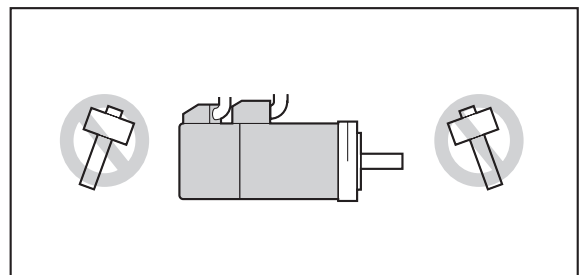

Connecting to Mechanical Systems

- For the allowable axial loads for motors, refer to 3-1-2 *Characteristics* on page 3-3. If an axial load greater than that specified is applied to a motor, it may reduce the limit of the motor bearings and may break the motor shaft.
- When connecting to a load, use couplings that can sufficiently absorb mechanical eccentricity and declination.
- For spur gears, an extremely large radial load may be applied depending on the gear precision. Use spur gears with a high degree of precision (for example, JIS class 2: normal line pitch error of 6 μm max. for a pitch circle diameter of 50 mm).
- If the gear precision is not adequate, allow backlash to ensure that no radial load is placed on the motor shaft.
- When using bevel gears, a load is applied in the thrust direction depending on the structural precision, the gear precision, and temperature changes. Provide appropriate backlash or take other measures to ensure that a thrust load larger than the specified level is not applied.
- Do not put rubber packing on the flange surface. If the flange is mounted with rubber packing, the motor flange may crack under the tightening force.
- When connecting to a V-belt or timing belt, consult the manufacturer for belt selection and tension.
- A radial load twice as large as the belt tension will be placed on the motor shaft. Do not allow a load that exceeds the allowable radial load to be placed on the motor shaft. If an excessive radial load is applied, the motor shaft and bearings may be damaged.
- Set up a movable pulley in the middle of the motor shaft and the load shaft so that the belt tension can be adjusted.

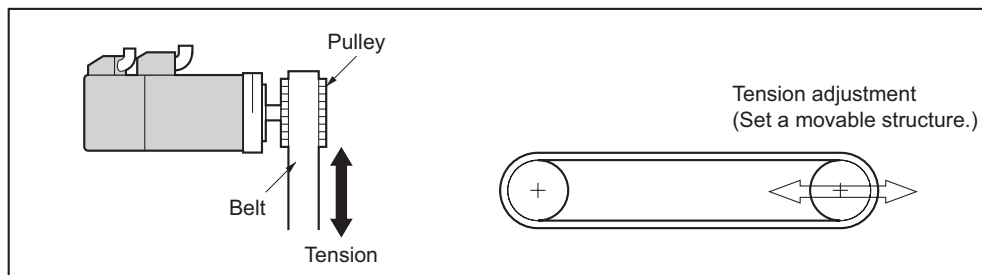
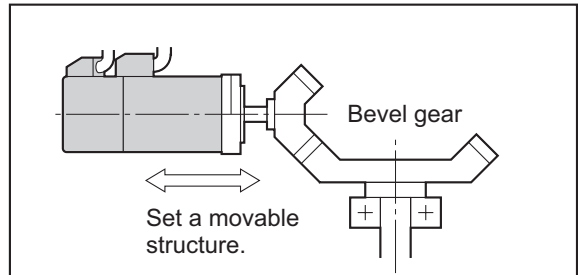
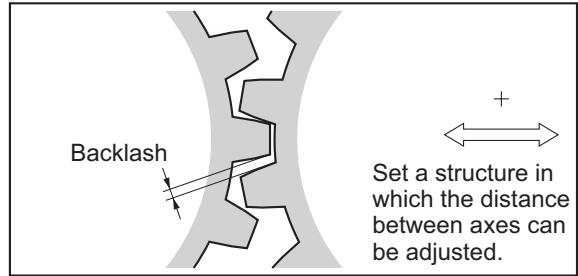
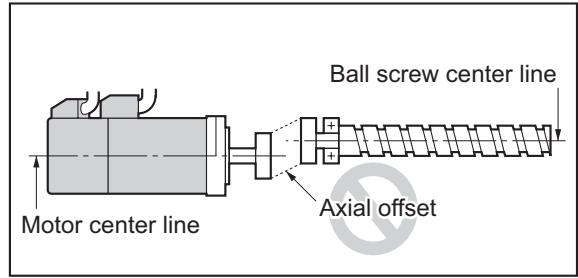

Water and Drip Resistance

- The protective structure for the motors is as follows:
Equivalent to IP65 (except for through-shaft parts)

Oil-water Measures

Use the Servomotor with an oil seal if you are using it in an environment where oil drops can adhere to the through-shaft part. The operating conditions of the Servomotor with an oil seal are as follows:

- Keep the oil level below the lip of the oil seal.
- Prepare a good lubricated condition under which only oil droplets splash on the oil seal.
- If you are using the Servomotor with the shaft in upward direction, make sure that no oil accumulates on the lip of the oil seal.

Radiator Plate Installation Conditions

- When you mount a Servomotor onto a small device, be sure to provide enough radiation space on the mounting area. Otherwise the Servomotor temperature rises too high. One of the preventive measures is to install a radiator plate between the motor attachment area and the motor flange. (See below.)

Failure to follow this guideline may result in damaging the Servomotor due to a temperature rise. Refer to 3-3 *Servomotor Specifications* on page 3-36 for the radiator plate specifications.

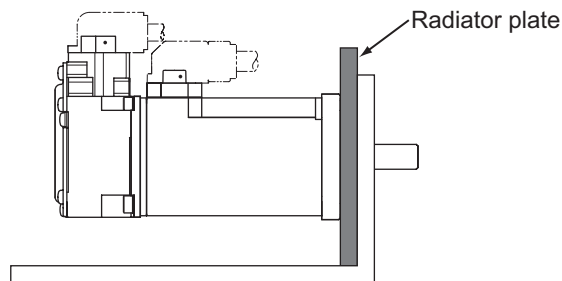

- The temperature rise depends on the mounting part materials and the installation environment. Check the actual temperature rise by using a real Servomotor.
- Depending on the environment, such as when the Servomotor is installed near a heating element, the Servomotor temperature may rise significantly. In this case, take any of the following measures.
 - Lower the load ratio.
 - Review the heat radiation conditions of the Servomotor.
 - Install a cooling fan and apply forced air cooling to the Servomotor.

Other Precautions

- Take measures to protect the motor shaft from corrosion. The motor shaft is coated with anti-corrosion oil when shipped, but anti-corrosion oil or grease should also be applied when connecting the components that apply load to the shaft.

Caution



Never repair the Servo Drive by disassembling it.
Electric shock or injury may result.



Do not apply a commercial power supply directly to the motor.
Fire may result.

4-1-3 Decelerator Installation Conditions

Installing the Decelerator

- **Installing the R88G-HPG□□□ (Backlash: 3 Arcminutes max.)**

Follow the instructions bellow to install the Decelerator and the Servomotor.

- 1 Turn the input joint and align the head of the bolt that secures the shaft with the rubber cap.**
- 2 Apply the sealant on the side which the Servomotor is installed. (Recommended sealant: Loctite 515)**
- 3 Gently insert the Servomotor into the decelerator.**

Put up the decelerator vertically and slide the Servomotor into the input shaft joint while using the motor shaft as guide not to fall over, as shown in the figures on the next page. When the decelerator cannot be put up vertically, tighten each bolt evenly little by little to ensure that the Servomotor is not inserted at a tilt.

- 4 Fix the Servomotor and the flange of the decelerator with bolts.**

Bolt tightening torque (for aluminum)

Allen head bolt size	M4	M5	M6	M8	M10	M12
Tightening torque [N·m]	3.2	6.3	10.7	26.1	51.5	89.9

- 5 Tighten the bolts of the input joint.**

Bolt tightening torque (for duralumin)

Allen head bolt size	M3	M4	M6	M8
Tightening torque [N·m]	2.0	4.5	15.3	37.2

Note Tighten the bolts to the torque indicated on the above table. The Servomotor may slip or other problems may occur if the specified torque level is not satisfied.

The R88G-HPG11A□ uses two set screws for the connecting section.

Allen head bolt size	M3
Tightening torque [N·m]	0.69

- 6 Mount the supplied rubber cap to complete the installation.**

(For the R88G-HPG11A□, mount two screws with gaskets.)

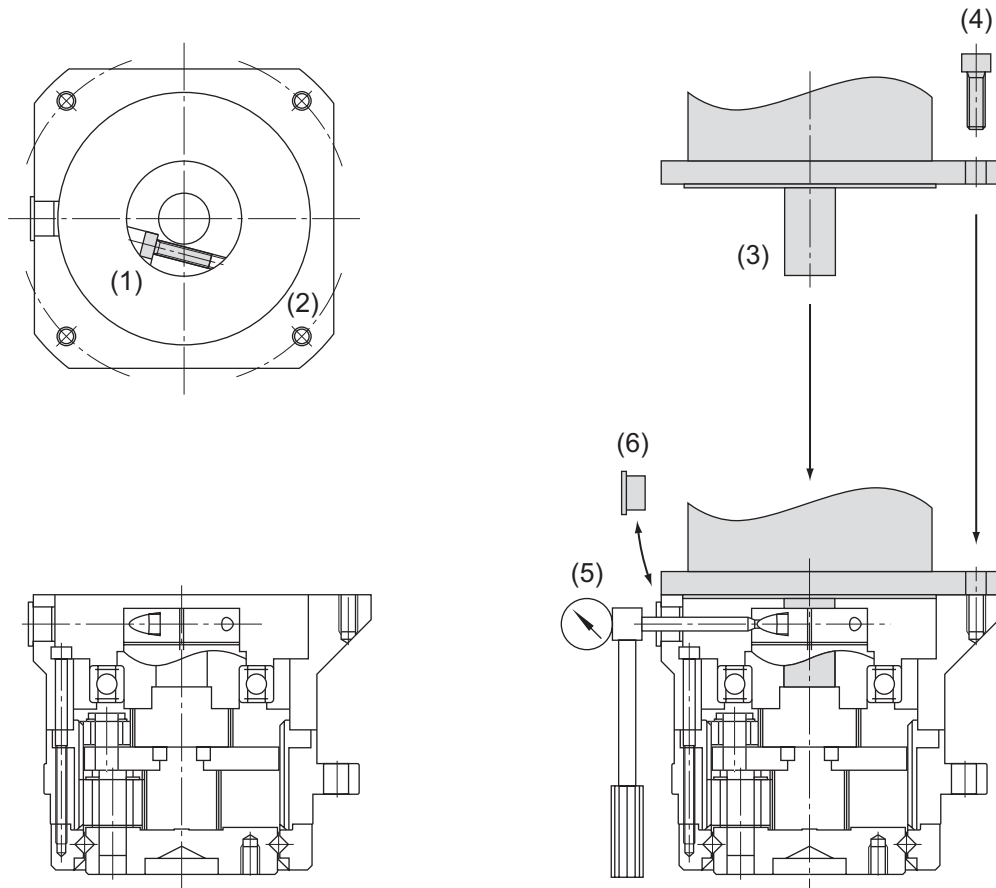

● Installing the Decelerator

When installing the R88G-HPG□□□□, first make sure that the mounting surface is flat and that there are no burrs on the tap sections, and then fix the mounting flanges with bolts.

Bolt tightening torque on the mounting flange (for aluminum)

R88G-HPG	11A	14A	20A	32A	50A	65A
Number of bolts	4	4	4	4	4	4
Size of bolts	M3	M5	M8	M10	M12	M16
Mounting PCD [mm]	46	70	105	135	190	260
Tightening torque [N·m]	1.4	6.3	26.1	51.5	103	255

Note Uninstalling the key on a Servomotor with key enables you to install the Servomotor to the decelerator. Slipping does not occur.

● Installing the R88G-VRSF□□□ (Backlash: 15 Arcminutes max.)

Follow the instructions below to install the Decelerator and the Servomotor.

- 1 Turn the input joint and align the head of the bolt that secures the shaft with the rubber cap.**

Confirm the set bolts are loose.

- 2 Gently insert the Servomotor into the decelerator.**

Put up the decelerator vertically and slide the Servomotor into the input shaft joint while using the motor shaft as guide not to fall over, as shown in the following figures. When the decelerator cannot be put up vertically, tighten each bolt evenly little by little to ensure that the Servomotor is not inserted at a tilt.

- 3 Fix the Servomotor and the flange of the decelerator with bolts.**

Bolt tightening torque

Allen head bolt size	M4	M5	M6
Tightening torque [N·m]	3.0	5.8	9.8

- 4 Tighten the bolts of the input coupling.**

Bolt tightening torque (for duralumin)

Allen head bolt size	M3	M4	M5
Tightening torque [N·m]	1.5	4.5	7.1

Note Tighten the bolts to the torque indicated on the above table. The Servomotor may slip or other problems may occur if the specified torque level is not satisfied.

- 5 Mount the supplied rubber cap to complete the installation.**

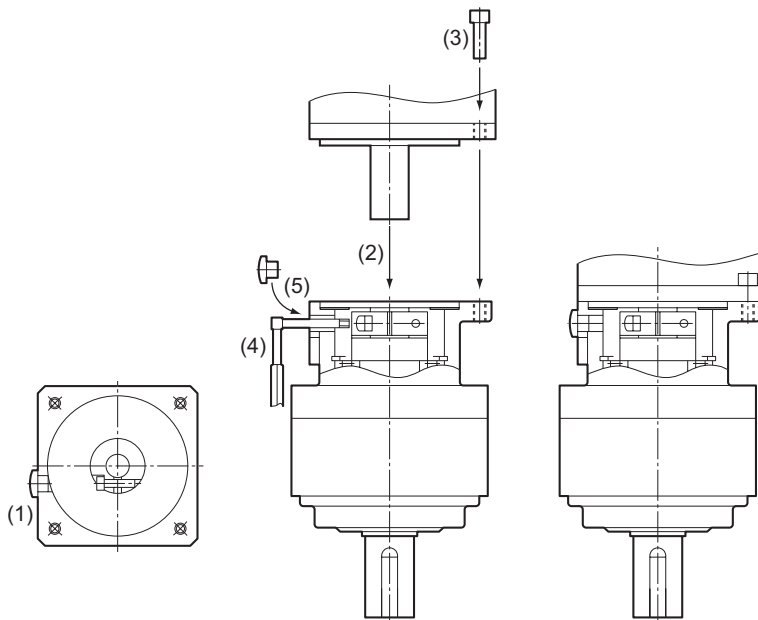

● Installing Decelerator

When installing the R88G-VRSF□□□, first make sure that the mounting surface is flat and that there are no burrs on the tap sections, and then fix the mounting flanges with bolts.

Bolt tightening torque on the mounting flange (for aluminum)

R88G-VRSF	Frame B	Frame C	Frame D
Number of bolts	4	4	4
Size of bolts	M5	M6	M8
Mounting PCD [mm]	60	90	115
Tightening torque [N·m]	5.8	9.8	19.6

Note Uninstalling the key on a Servomotor with key enables you to install the Servomotor to the decelerator. Slipping does not occur.

Using a Non-OMRON Decelerator (Reference)

If the system configuration requires a non-OMRON decelerator to be used in combination with an OMNUC G5-series (Pulse-train Input Type) Servomotor, select the decelerator so that the loads on the motor shaft (i.e., both the radial and thrust loads) are within the allowable ranges. (Refer to 3-1-2 *Characteristics* on page 3-3 for details on the allowable loads for the motors.)

Also, select the decelerator so that the allowable input rotation speed and allowable input torque of the decelerator are not exceeded.

4-2 Wiring

4-2-1 Peripheral Equipment Connection Examples

R88D-KP01H/-KP02H/-KP04H/-KP08H/-KP10H/-KP15H (For single-phase Input)

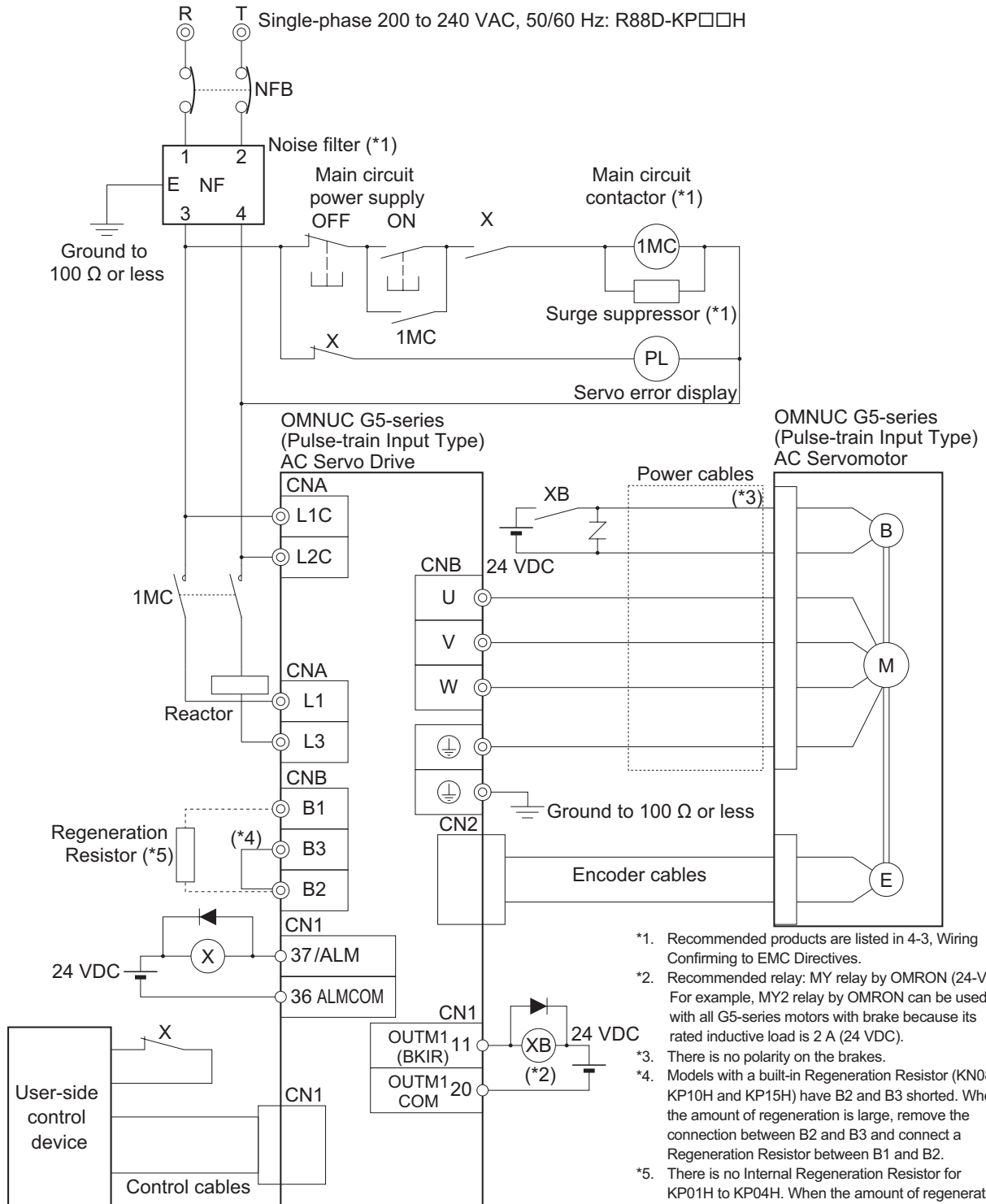

- *1. Recommended products are listed in 4-3, Wiring Confirming to EMC Directives.
- *2. Recommended relay: MY relay by OMRON (24-V) For example, MY2 relay by OMRON can be used with all G5-series motors with brake because its rated inductive load is 2 A (24 VDC).
- *3. There is no polarity on the brakes.
- *4. Models with a built-in Regeneration Resistor (KN08H, KP10H and KP15H) have B2 and B3 shorted. When the amount of regeneration is large, remove the connection between B2 and B3 and connect a Regeneration Resistor between B1 and B2.
- *5. There is no Internal Regeneration Resistor for KP01H to KP04H. When the amount of regeneration is large, connect the necessary Regeneration Resistor between B1 and B2.

R88D-KP01H/-KP02H/-KP04H/-KP08H/-KP10H/-KP15H (For 3-phase input)

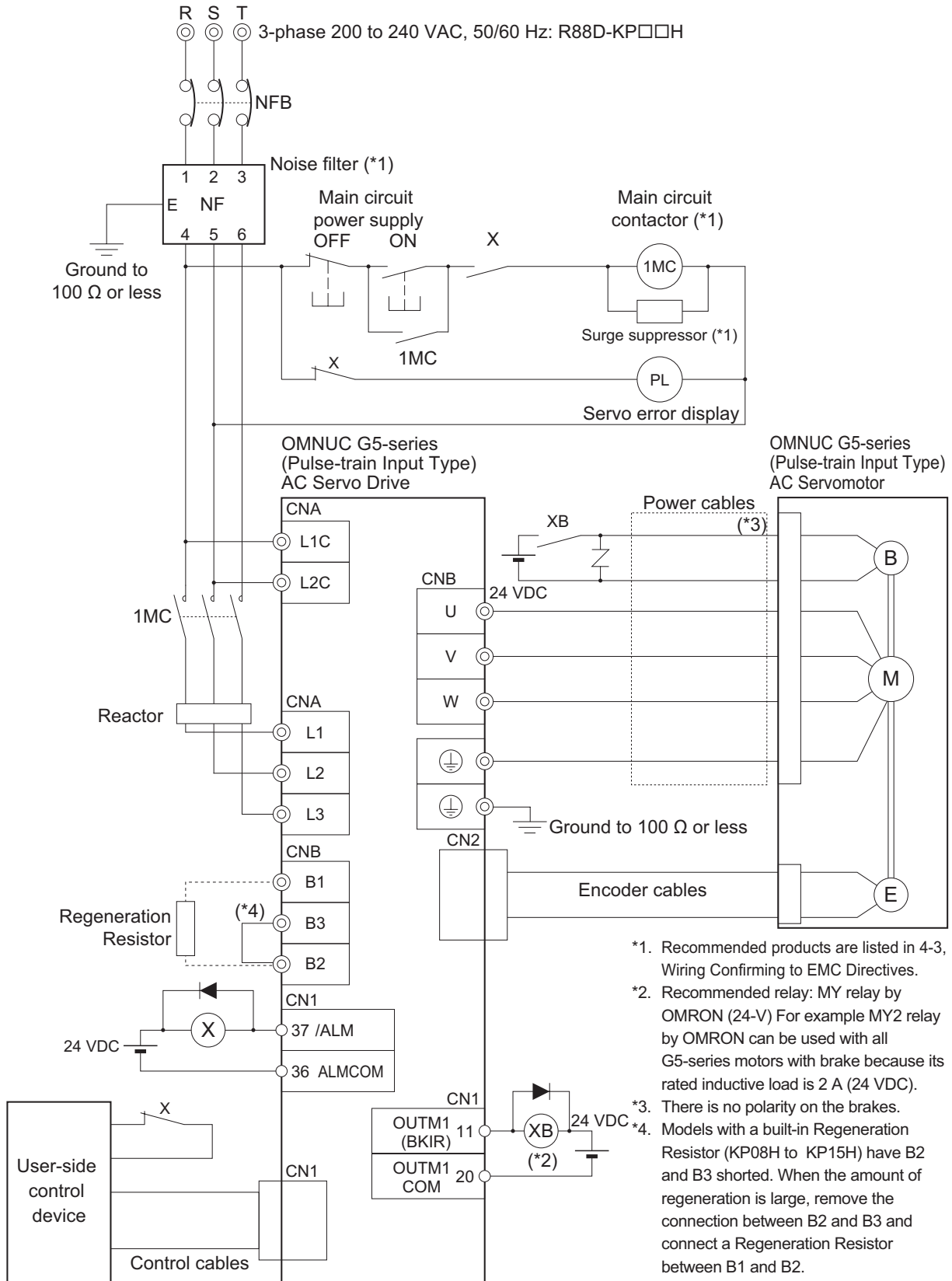

R88D-KP20H

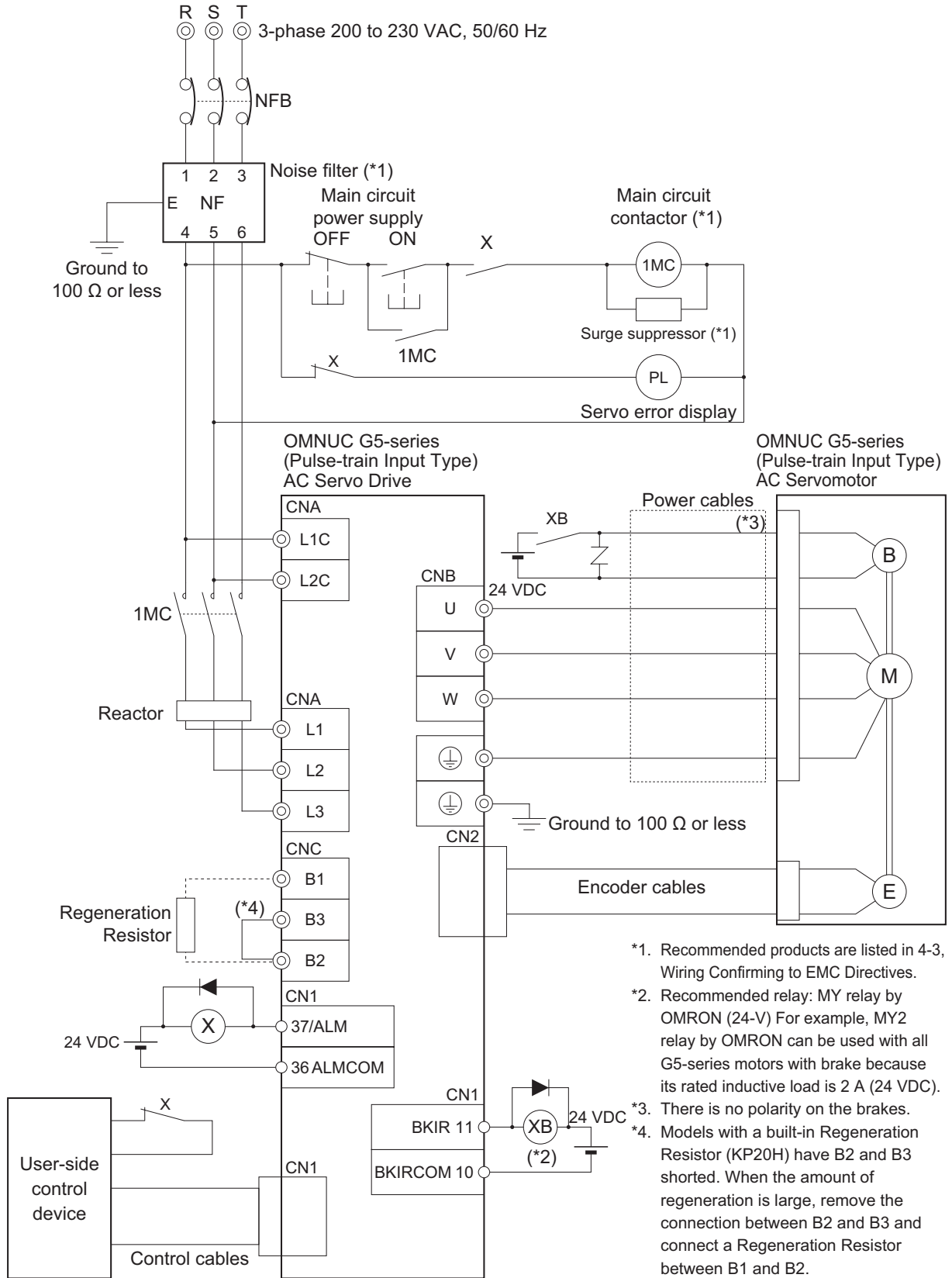

R88D-KP30H/-KP50H

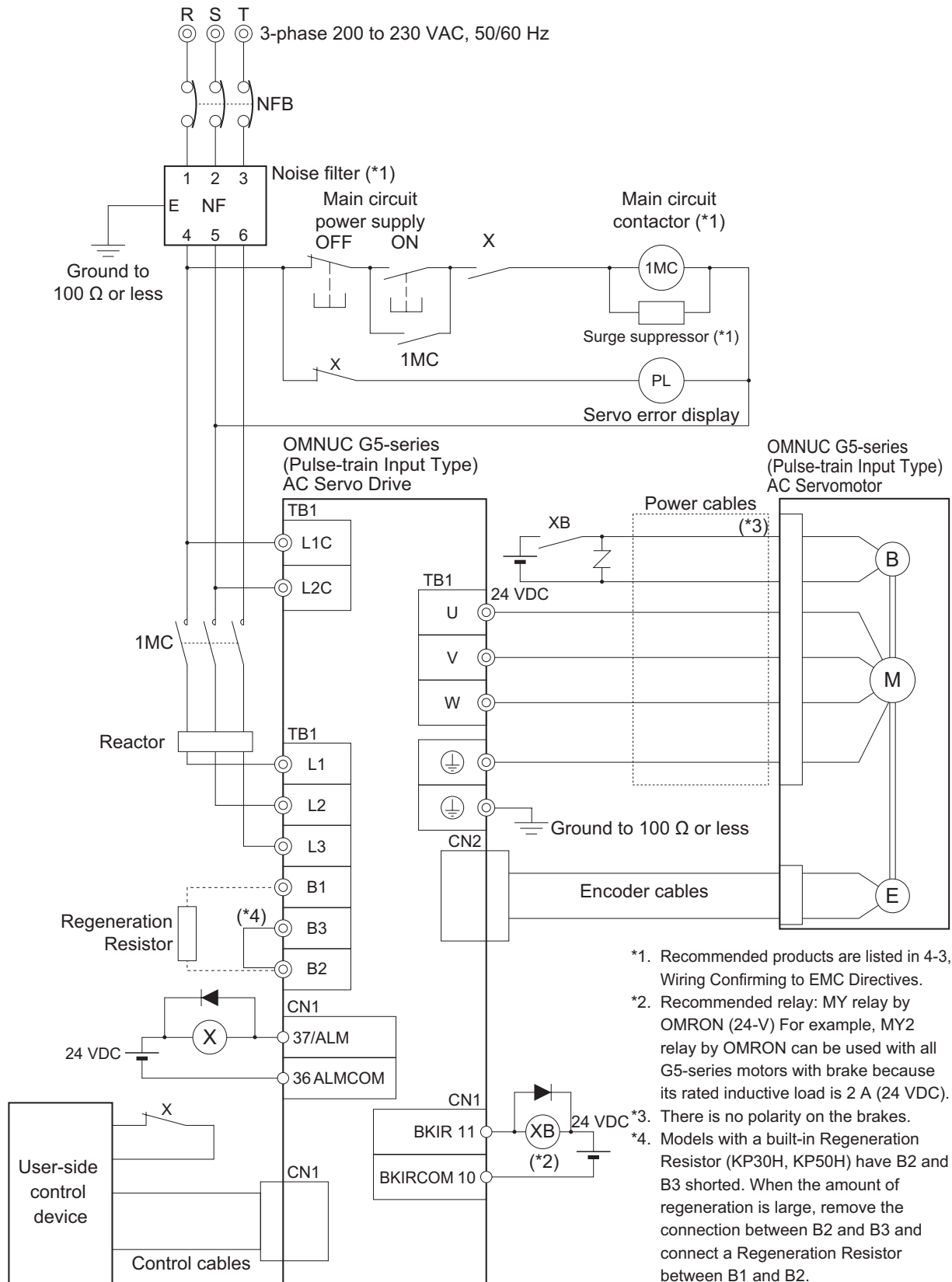

4-2-2 Main Circuit and Motor Connections

When wiring the main circuit, use proper wire sizes, grounding systems, and noise resistance.

R88D-KP01H/-KP02H/-KP04H/-KP08H/-KP10H/-KP15H

● Main Circuit Connector Specifications (CNA)

Symbol	Name	Function
L1	Main circuit power supply input	R88D-KP□H
L2		(100 W to 1.5 kW): Single-phase 200 to 240 VAC (170 to 264 VAC) 50/60 Hz
L3		(100 W to 1.5 kW): 3-phase 200 to 240 VAC (170 to 264 VAC) 50/60 Hz
L1C	Control circuit power supply input	R88D-KP□H: Single-phase 200 to 240 VAC (170 to 264 VAC) 50/60 Hz
L2C		

● Motor Connector Specifications (CNB)

Symbol	Name	Function
B1	External Regeneration Resistor connection terminals	50 to 400 W: Do not short B1 and B2. Doing so may result in malfunctioning. If there is high regenerative energy, connect an External Regeneration Resistor between B1 and B2. 750 W to 1.5 kW: Normally B2 and B3 are shorted. Do not short B1 and B2. Doing so may result in malfunctioning. If there is high regenerative energy, remove the short-circuit bar between B2 and B3 and connect an External Regeneration Resistor between B1 and B2.
B3		
B2		
U	Motor connection terminals	Red
V		White
W		Blue
⊕		Green/ Yellow
⊕	Frame ground	This is the ground terminal. Ground to 100 Ω or less.

R88D-KP20H

● Main Circuit Connector Specifications (CNA)

Symbol	Name	Function
L1	Main circuit power supply input	R88D-KP□H (2 kW): 3-phase 200 to 230 VAC (170 to 253 VAC) 50/60 Hz
L2		
L3		
L1C	Control circuit power supply input	R88D-KP□H: Single-phase 200 to 230 VAC (170 to 253 VAC) 50/60 Hz
L2C		

● Motor Connector Specifications (CNB)

Symbol	Name	Function	
U	Motor connection terminals	Red	These are the output terminals to the Servomotor. Be sure to wire them correctly.
V		White	
W		Blue	
⊕		Green/ Yellow	
⊕	Frame ground	This is the ground terminal. Ground to 100 Ω or less.	

● External Regeneration Resistor Connector Specifications (CNC)

Symbol	Name	Function
B1	External Regeneration Resistor connection terminals	Normally B2 and B3 are shorted. Do not short B1 and B2. Doing so may result in malfunctioning. If there is high regenerative energy, remove the short-circuit bar between B2 and B3 and connect an External Regeneration Resistor between B1 and B2.
B3		
B2		
NC	Do not connect.	



Precautions for Correct Use

Do not connect any External Regeneration Resistors between B1 and NC.

R88D-KP30H/-KP50H

● Terminal Block Specifications

Symbol	Name	Function	
L1	Main circuit power supply input	R88D-KP□H (3 to 5 kW): 3-phase 200 to 230 VAC (170 to 253 VAC) 50/60 Hz	
L2			
L3			
L1C	Control circuit power supply input	R88D-KP□H: Single-phase 200 to 230 VAC (170 to 253 VAC) 50/60 Hz	
L2C			
B1	External Regeneration Resistor connection terminals	Normally B2 and B3 are shorted. Do not short B1 and B2. Doing so may result in malfunctioning. If there is high regenerative energy, remove the short-circuit bar between B2 and B3 and connect an External Regeneration Resistor between B1 and B2.	
B3			
B2			
NC	Do not connect.		
U	Motor connection terminals	Red	These are the output terminals to the Servomotor. Be sure to wire them correctly.
V		White	
W		Blue	
⊕		Green/ Yellow	
⊕	Frame ground	This is the ground terminal. Ground to 100 Ω or less.	



Precautions for Correct Use

Do not connect any External Regeneration Resistors between B1 and NC.

Terminal Block Wire Sizes

● 200-VAC Input Drive Wire Sizes: R88D-KP□□H

Model (R88D-)		Item	Unit	KP01H	KP02H	KP04H	KP08H	KP10H
Power supply capacity		kVA		0.5	0.5	0.9	1.3	1.8
Main circuit power supply input (L1 and L3, or L1, L2 and L3)	Rated current	A	1.6/0.9 ^{*1}	2.4/1.3 ^{*1}	4.1/2.4 ^{*1}	6.6/3.6 ^{*1}	9.1/5.2 ^{*1}	
	Wire size	–	AWG 14 to 18				AWG 14	
	Screw size	–	–	–	–	–	–	
	Tightening torque	N·m	–	–	–	–	–	
Control circuit power supply input (L1C and L2C)	Wire size	–	AWG 18					
	Screw size	–	–	–	–	–	–	
	Tightening torque	N·m	–	–	–	–	–	
Motor connection terminals (U, V, W, and FG) ^{*2 *3}	Rated current	A	1.2	1.6	2.6	4.1	5.9	
	Wire size	–	AWG 14 to 18				AWG 14	
	Screw size	–	–	–	–	–	–	
	Tightening torque	N·m	–	–	–	–	–	
Frame ground (FG)	Wire size	–	AWG 14					
	Screw size	–	M4					
	Tightening torque	N·m	1.2					

Model (R88D-)		Item	Unit	KP15H	KP20H	KP30H	KP50H
Power supply capacity		kVA		2.3	3.3	4.5	7.5
Main circuit power supply input (L1 and L3, or L1, L2 and L3)	Rated current	A	14.2/8.1 ^{*1}	11.8	15.1	21.6	
	Wire size	–	AWG 14		AWG 12		
	Screw size	–	–	–	M5		
	Tightening torque	N·m	–	–	2.0		
Control circuit power supply input (L1C and L2C)	Wire size	–	AWG 18				
	Screw size	–	–	–	M5		
	Tightening torque	N·m	–	–	2.0		
Motor connection terminals (U, V, W, and FG) ^{*2 *3}	Rated current	A	9.4	13.4	18.7	33.0	
	Wire size	–	AWG 14		AWG 12		
	Screw size	–	–	–	M5		
	Tightening torque	N·m	–	–	2.0		
Frame ground (FG)	Wire size	–	AWG 14		AWG 12		
	Screw size	–	M4		M5		
	Tightening torque	N·m	1.2		2.0		
Dynamic brake resistor control terminals	Wire size	–	–				
	Screw size	–	–				
	Tightening torque	N·m	–				

*1 The first value is for single-phase input power and the second value is for 3-phase input power.

*2 Use the same wire size for B1 and B2.

*3 Connect an OMRON power cable to the motor connection terminals.

Wire Sizes and Allowable Current (Reference)

The following table shows the allowable current when there are 3 power supply wires. Use a current below these specified values.

● 600-V Heat-resistant Vinyl Wire (HIV)

AWG size	Nominal cross-sectional area [mm ²]	Configuration [wires/mm ²]	Conductive resistance [Ω /km]	Allowable current [A] for ambient temperature		
				30°C	40°C	50°C
20	0.5	19/0.18	39.5	6.6	5.6	4.5
–	0.75	30/0.18	26.0	8.8	7.0	5.5
18	0.9	37/0.18	24.4	9.0	7.7	6.0
16	1.25	50/0.18	15.6	12.0	11.0	8.5
14	2.0	7/0.6	9.53	23	20	16
12	3.5	7/0.8	5.41	33	29	24
10	5.5	7/1.0	3.47	43	38	31
8	8.0	7/1.2	2.41	55	49	40
6	14.0	7/1.6	1.35	79	70	57
4	22.0	7/2.0	0.85	99	88	70

Terminal Block Wiring Procedure

On a Servo Drive with 2.0 kW or less, connector-type terminal blocks are used.

The procedure for wiring these terminal blocks is explained below.

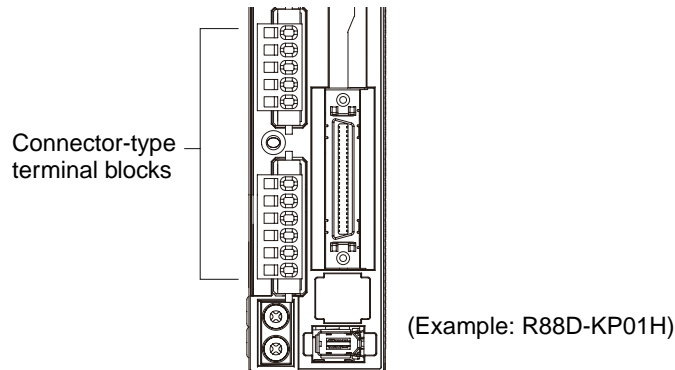

1 Remove the terminal block from the Servo Drive before wiring.

The Servo Drive may be damaged if the wiring is done with the terminal block in place.

2 Strip off 8 to 9 mm of the covering from the end of each wire.

Refer to 4-2-2 Main Circuit and Motor Connections on page 4-14 for applicable wire sizes.

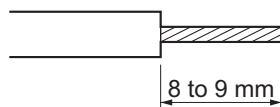

3 Open the wire insertion slots in the terminal block using a tool.

There are two ways to open the wire insertion slots, as follows.

- Pry the slot open using the lever that comes with the Servo Drive. (Figure A)
- Insert a flat-blade screwdriver (end width: 3.0 to 3.5 mm) into the opening for the driver on the terminal block, and press down firmly to open the slot. (Figure B)

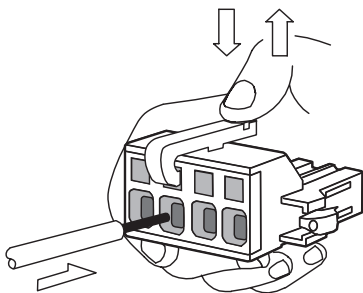

Figure A

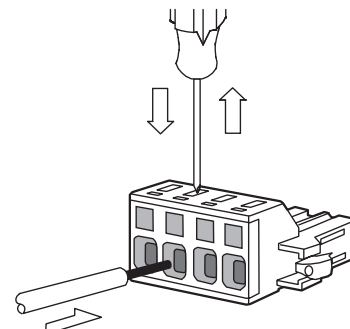

Figure B

4 With the wire insertion slot held open, insert the end of the wire.

After inserting the wire, let the slot close by releasing the pressure from the lever or the screwdriver.

5 Mount the terminal block to the Servo Drive.

After all of the terminals have been wired, return the terminal block to its original position on the Servo Drive.

Note The wire may not be inserted easily depending on the shape of the ferrule connected to it. If this occurs, perform one of the following methods before inserting the wire.

- Change the direction of inserting the connector by 90°.
- Correct the shape of the ferrule with pliers.

4-3 Wiring Conforming to EMC Directives

Conformance to the EMC Directives (EN 55011 Class A Group 1 (EMI) and EN 61000-6-2 (EMS)) can be ensured by wiring under the conditions described in this section.

These conditions are for conformance of OMNUC G5-series (Pulse-train Input Type) products to the EMC directives. EMC-related performance of these products, however, may be influenced by the configuration, wiring, and other conditions of the equipment in which the products are installed. The EMC conformance of the system as a whole must be confirmed by the customer.

The following are the requirements for EMC Directive conformance.

- The Servo Drive must be installed in a metal case (control panel). (The motor does not, however, have to be covered with a metal plate.)
- Noise filters and lightning surge absorptive elements (surge absorbers) must be installed on power supply lines.
- Braided shielded cables must be used for encoder cables. (Use tin-plated, mild steel wires for the shielding.)
- All cables, I/O wiring, and power lines connected to the Servo Drive must have clamp cores installed.
- The shields of all cables must be directly connected to a ground plate.

4-3-1 Wiring Method

● R88D-KP01H/-KP02H/-KP04H/-KP08H/-KP10H/-KP15H/-KP20H/-KP30H/-KP50H

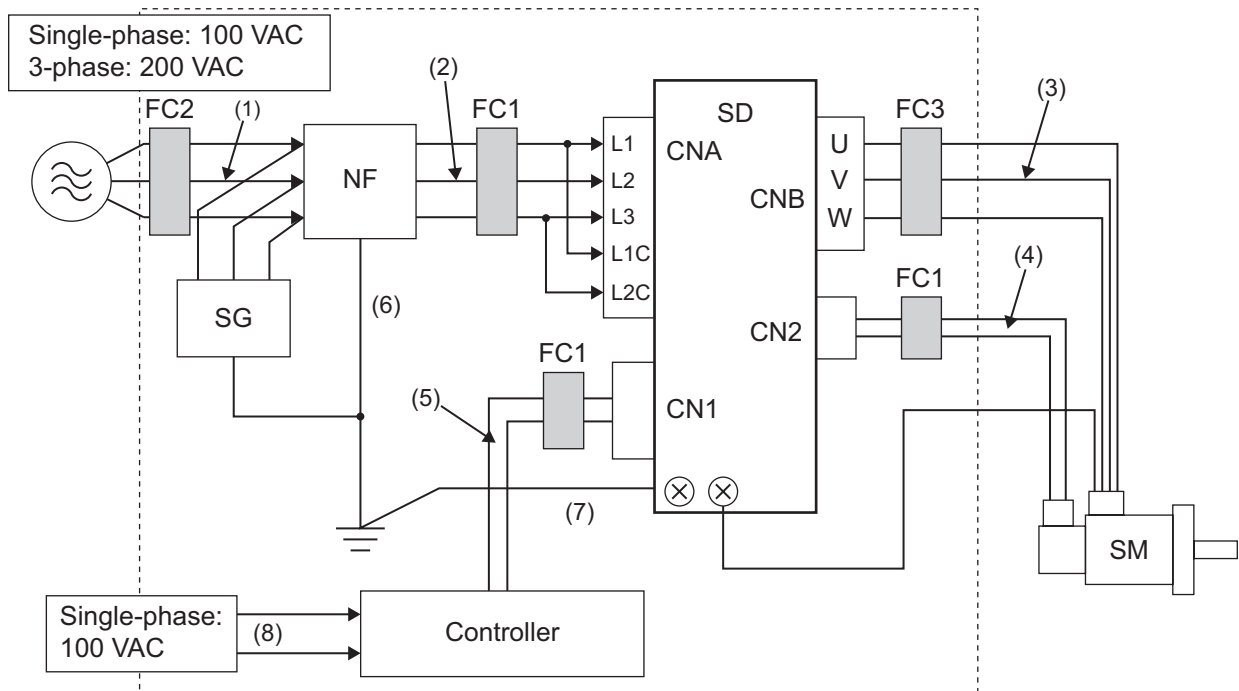

- For models with a single-phase power supply input (R88D-KP01H/-KP02H/-KP04H/-KP08H/-KP10H/-KP15H), the main circuit power supply input terminals are L1 and L3.
- Ground the motor's frame to the machine ground when the motor is on a movable shaft.
- Use a ground plate for the frame ground for each unit, as shown in the above diagrams, and ground to a single point.
- Use ground lines with a minimum thickness of 3.5 mm^2 , and arrange the wiring so that the ground lines are as short as possible.
- A no-fuse breaker, surge absorber, and noise filter should be positioned near the input terminal block (ground plate), and I/O lines should be separated and wired at the shortest distance.

● Unit Details

Symbol	Name	Manufacturer	Model	Comment
SG	Surge absorber	Okaya Electric Industries Co., Ltd.	R·A·V-781BXZ-4	3-phase 200 VAC
NF	Noise filters	Okaya Electric Industries Co., Ltd.	SUP-EK5-ER-6	Single-phase 100/200 VAC (5 A)
			3SUP-HU10-ER-6	3-phase 200 VAC (10 A)
			3SUP-HU30-ER-6	3-phase 200 VAC (30 A)
			3SUP-HL50-ER-6B	3-phase 200 VAC (50 A)
		Schaffner EMC Inc.	FS5559-60-34	3-phase 200 VAC (60 A)
			FS5559-80-34	3-phase 200 VAC (80 A)
SD	Servo Drive	OMRON	–	*1
SM	Servomotor	OMRON	–	*1
FC1	Clamp core	TDK	ZCAT3035-1330	–
FC2	Clamp core	Konno Industry	RJ8035	–
			RJ8095	
FC3	Clamp core	TDK	ZCAT3035-1330	–
–	Controller	–	–	–

*1 A specified combination of Servo Drive and Servomotor must be used.

● Cable Details

Symbol	Supplies from	Connects to	Cable name	Length	Comment	Shielded	Ferrite
(1)	AC power supply	Noise filters	Power supply line	2 m	–	No	No
(2)	Noise filters	Servo Drive	Power supply line	2 m	–	No	Optional
(3)	Servo Drive	Servomotor	Power cable	20 m	–	No	Optional
(4)	Servo Drive	Servomotor	Encoder cable	20 m	–	Yes	Optional
(5)	Switch box	Servo Drive	I/O cable	2 m	–	No	Optional
(6)	Frame ground	Noise filters	FG line	1.5 m	–	No	No
(7)	Frame ground	Servo Drive	FG line	1.5 m	–	No	No
(8)	AC power supply	Controller	Power supply line	1.5 m	–	No	No

Noise filter for power supply input

We recommend using a noise filter listed below for the Servo Drive.

Drive		Noise filter for power supply input			Manufacturer
Phase of power supply	Model	Model	Rated current	Leakage current (60 Hz) max.	
Single-phase	R88D-KP□01H□□	SUP-EK5-ER-6	5 A	1.0 mA (at 250 VAC)	Okaya Electric Industries Co., Ltd.
3-phase		3SUP-HU10-ER-6	10 A	3.5 mA (at 500 VAC)	
Single-phase	R88D-KP□02H□□	SUP-EK5-ER-6	5 A	1.0 mA (at 250 VAC)	
3-phase		3SUP-HU10-ER-6	10 A	3.5 mA (at 500 VAC)	
Single-phase	R88D-KP□04H□□	SUP-EK5-ER-6	5 A	1.0 mA (at 250 VAC)	
3-phase		3SUP-HU10-ER-6	10 A	3.5 mA (at 500 VAC)	
Single-phase, 3-phase	R88D-KP□08H□□	3SUP-HU30-ER-6	30 A	3.5 mA (at 500 VAC)	
	R88D-KP□10H□□				
	R88D-KP□15H□□				
3-phase	R88D-KP□20H□□	3SUP-HU50-ER-6	50 A	3.5 mA (at 500 VAC)	
	R88D-KP□30H□□	3SUP-HL50-ER-6B	50 A	8.0 mA (at 500 VAC)	
	R88D-KP□50H□□				

- For operational reasons, if no-fuse breakers are installed at the top and the power supply line is wired from the lower duct, use metal tubes for wiring or make sure that there is adequate distance between the input lines and the internal wiring. If input and output lines are wired together, noise resistance will decrease.
- The noise filter must be installed as close as possible to the entrance of the control panel. Wire as shown at the left in the following illustration.

○ Separate the input and output.

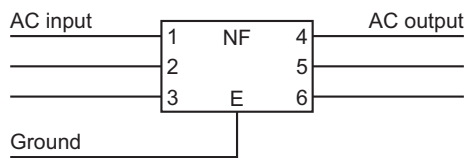

⊘ The effect of the noise filter is small.

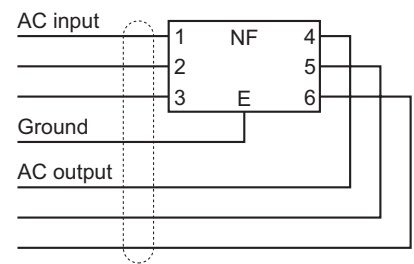

- Use twisted-pair cables for the power supply cables, or bind the cables.

○ Twisted-pair cables

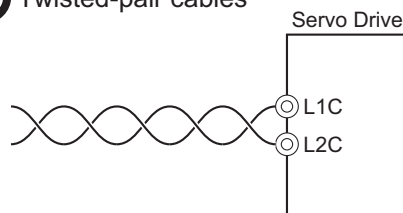

○ Bound cables

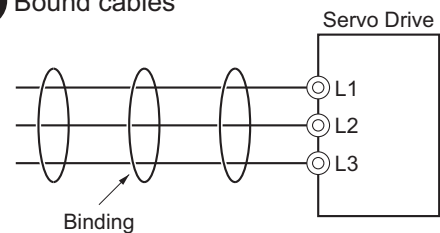

- Separate power supply lines and signal lines when wiring.

● External Dimensions

SUP-EK5-ER-6/3SUP-HQ10-ER-6

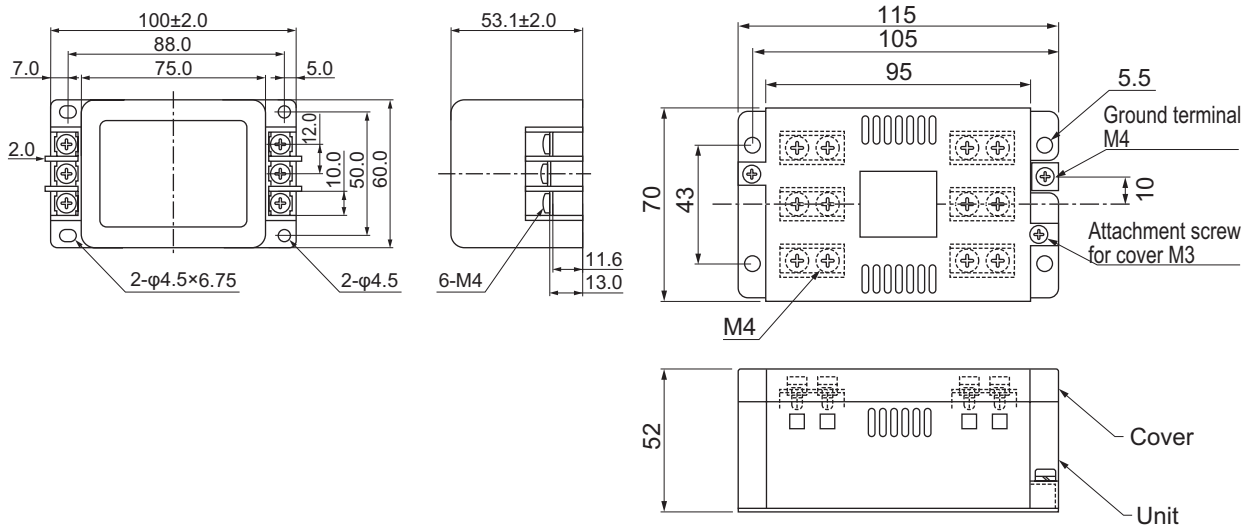

3SUP-HU30-ER-6/3SUP-HL50-ER-6B

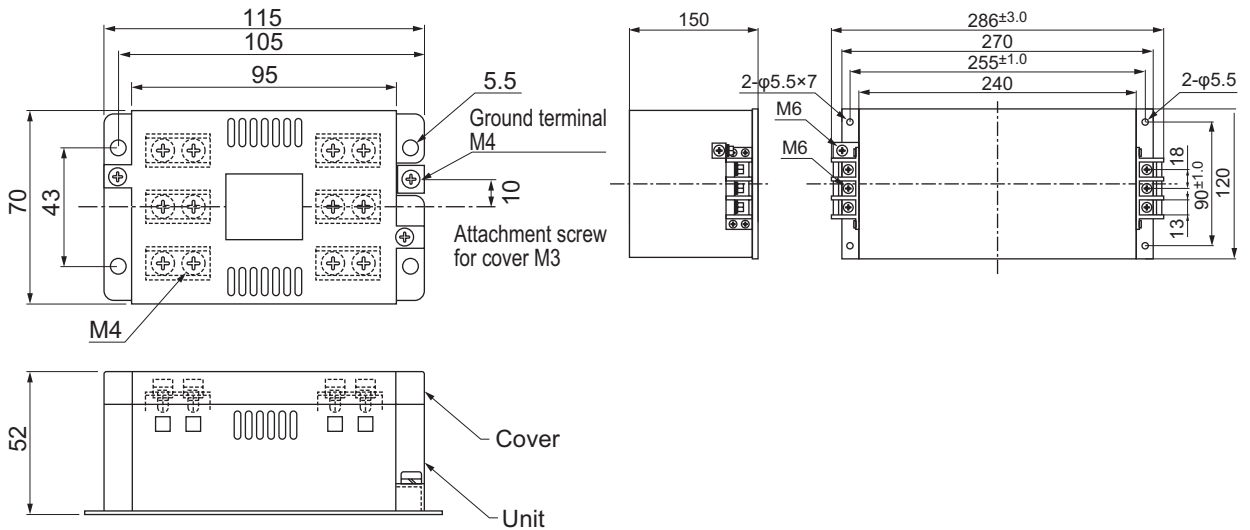

● **Circuit Diagram**

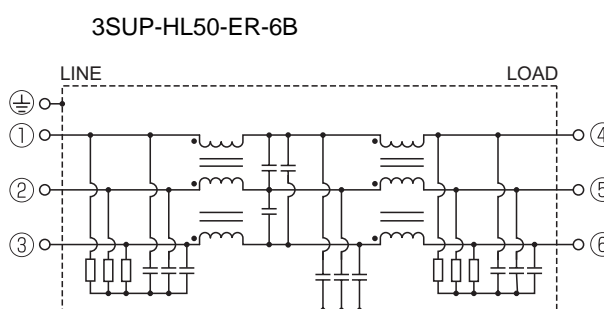
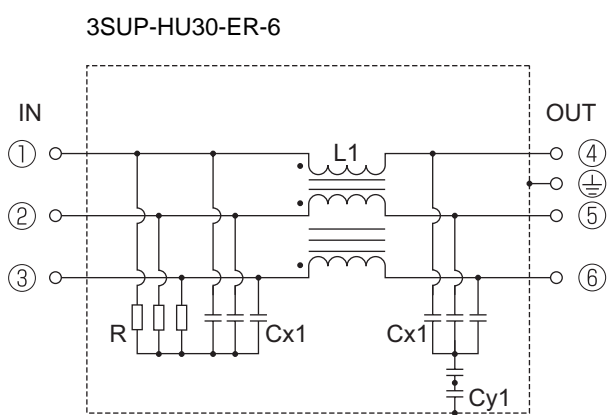
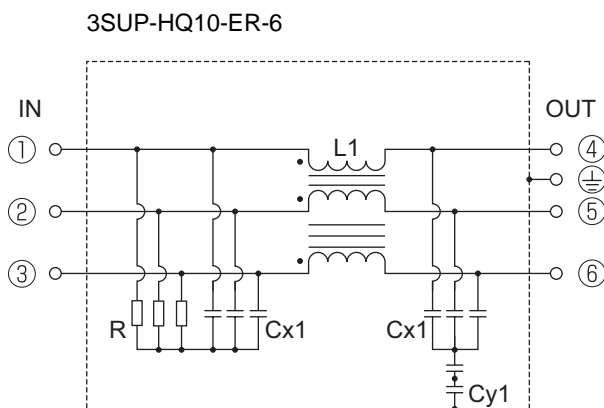
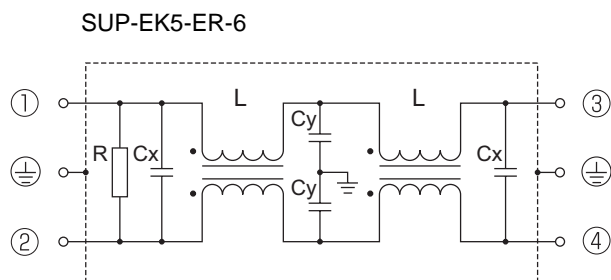

Noise Filter for Brake Power Supply

- Use the following noise filter for the brake power supply.

Model	Rated current	Rated voltage	Leakage current	Manufacturer
SUP-EK5-ER-6	5 A	250 V	1.0 mA (at 250 Vrms 60 Hz)	Okaya Electric Industries Co., Ltd.

Note Noise can also be reduced by using a ZCAT3035-1330 radio noise filter (TDK) with 1.5 turns.

Control Panel Structure

Openings in the control panel, such as holes for cables, panel mounting holes, and gaps around the door, may allow electromagnetic waves into the panel. To prevent this, observe the recommendations described below when designing or selecting a control panel.

● **Case Structure**

- Use a metal control panel with welded joints at the top, bottom, and sides so that the surfaces are electrically conductive.
- If assembly is required, strip the paint off the joint areas (or mask them during painting), to make them electrically conductive.
- The panel may warp and gaps may appear when screws are tightened. Be sure that no gaps appear when tightening screws.
- Do not leave any conductive part unconnected.
- Ground all units within the case to the case itself.

● Door Structure

- Use a metal door.
- Use a water-draining structure where the door and case fit together, and leave no gaps. (Refer to the diagrams.)
- Use a conductive gasket between the door and the case. (Refer to the diagrams.)
- Strip the paint off the sections of the door and case that will be in contact with the conductive gasket (or mask them during painting), so that they are electrically conductive.
- The panel may warp and gaps may appear when screws are tightened. Be sure that no gaps appear when tightening screws.

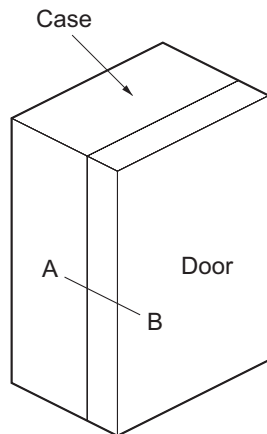

Control Panel

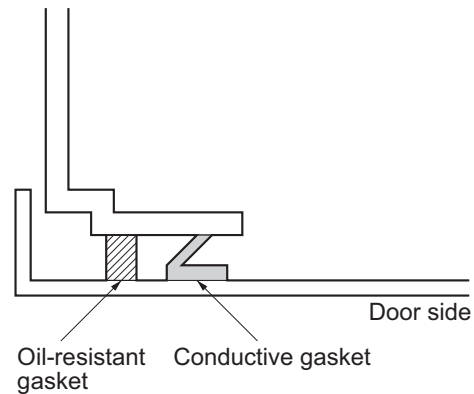

A-B Cross-section Diagram

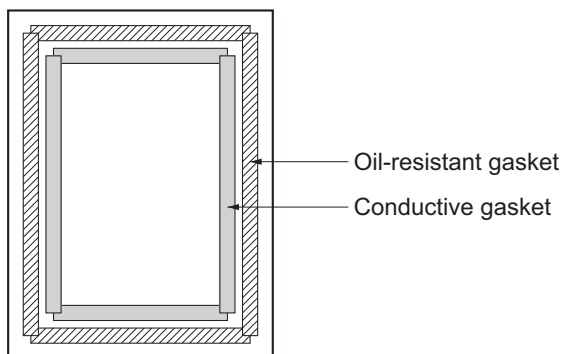

Door (Interior Side)

4-3-2 Selecting Connection Components

This section explains the criteria for selecting the connection components required to improve noise resistance.

Understand each component's characteristics, such as its capacity, performance, and applicable range when selecting the connection components.

For more details, contact the manufacturers directly.

No-fuse Breaker (NFB)

When selecting a no-fuse breaker, consider the maximum input current and the inrush current.

● Maximum Input Current

- The momentary maximum output of Servo Drive is approximately three times the rated output, and can be output for up to 3 seconds.
Therefore, select no-fuse breakers with an operation time of at least 5 seconds at 300% of the rated current ratio. General or low-speed no-fuse breakers is suitable.
- Select a no-fuse breaker with a rated current greater than the total effective load current of all the motors (when multiple Servo Drives are used). (The rated current of the power supply input for each motor is provided in *4-2-2 Main Circuit and Motor Connections* on page 4-14.)
- Add the current consumption of other controllers, and any other components when selecting.

● Inrush Current

- The following table lists the Servo Drive inrush currents.
- With low-speed no-fuse breakers, an inrush current 10 times the rated current can flow for 0.02 second.
- When the power of multiple Servo Drives are turned ON simultaneously, select a no-fuse breaker with a 20-ms allowable current that is greater than the total amount of the inrush current in the following table.

Servo Drive model	Inrush current (Ao-p)	
	Main circuit power supply	Control circuit power supply
R88D-KP01H	14	28
R88D-KP02H	14	28
R88D-KP04H	14	28
R88D-KP08H	29	28
R88D-KP10H	29	28
R88D-KP15H	29	28
R88D-KP20H	29	14
R88D-KP30H	22	14
R88D-KP50H	22	14

Leakage Breaker

- Select a leakage breaker for high frequencies and surge resistance.
- When selecting leakage breakers, remember to add the leakage current from devices other than the motor, such as devices using a switching power supply, noise filters, inverters, and so on. To prevent malfunction due to inrush current, we recommend using a leakage breaker of 10 times the total of all current values.
- The leakage breaker is activated at 50% of the rated current. Select a leakage breaker with approximately twice the capacity.
- For details on leakage breakers selection method, refer to the manufacturer's catalog.
- Because switching takes place inside the Servo Drives, high-frequency current leaks from the SW elements of the Servo Drive, the armature of the motor, and the cables. High-frequency and surge-resistant leakage breakers can prevent operation with high-frequency leakage current because they do not detect high-frequency current. When using a general leakage breaker, use three times the total of the leakage current given in the following table as a reference value.

Servo Drive model	Input power supply	Leakage current (Cable: 3 m)	Increase per 10 m of cable
R88D-KP01H	Single-phase 200 V	0.83 mA	0.23 mA
	3-phase 200 V	1.03 mA	
R88D-KP02H	Single-phase 200 V	0.84 mA	
	3-phase 200 V	1.02 mA	
R88D-KP04H	Single-phase 200 V	0.96 mA	0.3 mA
	3-phase 200 V	1.27 mA	
R88D-KP08H	Single-phase 200 V	1.01 mA	1.1 mA
	3-phase 200 V	1.39 mA	
R88D-KP10H	Single-phase 200 V	0.88 mA	0.93 mA
	3-phase 200 V	1.14 mA	
R88D-KP15H	Single-phase 200 V	0.96 mA	
	3-phase 200 V	1.18 mA	
R88D-KP20H	3-phase 200 V	1.53 mA	1.23 mA
R88D-KP30H	3-phase 200 V	1.52 mA	
R88D-KP50H	3-phase 200 V	1.39 mA	

Note These values vary greatly depending on the installation conditions of the motor power cable and the measurement conditions. Use the values for reference only.

Surge Absorber

- Use surge absorbers to absorb lightning surge voltage and abnormal voltage from power supply input lines.
- When selecting surge absorbers, take into account the varistor voltage, the surge immunity and the energy tolerated dose.
- For 200-VAC systems, use surge absorbers with a varistor voltage of 620 V.
- The surge absorbers shown in the following table are recommended.

Manufacturer	Model	Surge immunity		Type	Comment
Okaya Electric Industries Co., Ltd.	R-A-V-781BWZ-4	700 V ± 20%	2,500 A	Block	Single-phase 200 VAC
Okaya Electric Industries Co., Ltd.	R-A-V-781BXZ-4	700 V ± 20%	2,500 A		3-phase 200 VAC

Note 1 Refer to the manufacturers' catalog for operating details.

- 2 The surge immunity is for a standard impulse current of 8/20 s. If pulses are wide, either decrease the current or change to a larger-capacity surge absorber.

External Dimensions

For single-phase (BWZ series)

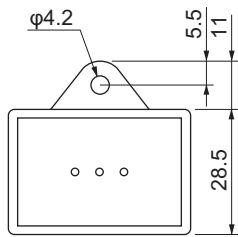

For 3-phase (BXZ series)

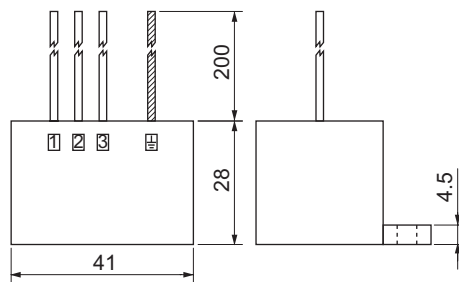
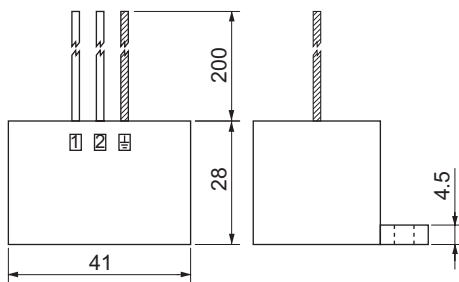
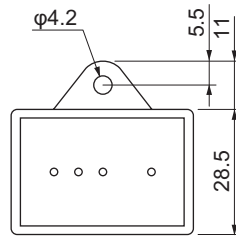

Equalizing Circuits

For single-phase (BWZ series) For 3-phase (BXZ series)

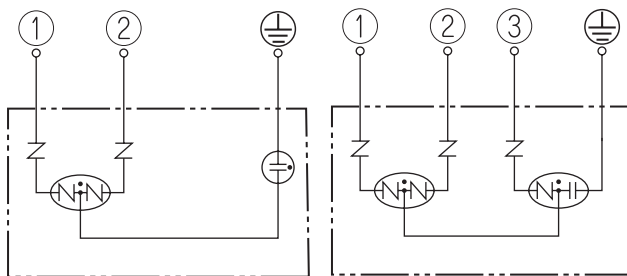

Radio Noise Filter and Emission Noise Prevention Clamp Core

Use one of the following filters to prevent switching noise of PWM of the Servo Drive and to prevent noise emitted from the internal clock circuit.

Model	Manufacturer	Application
3G3AX-ZCL1 ^{*1}	OMRON	For Drive output and power cable
3G3AX-ZCL2 ^{*2}	OMRON	For Drive output and power cable
ESD-R-47B ^{*3}	NEC TOKIN	For Drive output and power cable
ZCAT3035-1330 ^{*4}	TDK	For Encoder cable and I/O cable
RJ8035	Konno Industry	For power supply line
RJ8095	Konno Industry	For power supply line
T400-61D	MICROMETALS	For Drive output and power cable

*1 Generally used for 1.5 kW or higher.

*2 Generally used for 1.5 kW or lower. The maximum number of windings is 3 turns.

*3 Generally used for 50/100 W. The maximum number of windings is 2 turns.

*4 Also used on the Drive output power lines to comply with the EMC Directives. Only a clamp is used. This clamp can also be used to reduce noise current on a FG line.

● External Dimensions

3G3AX-ZCL1

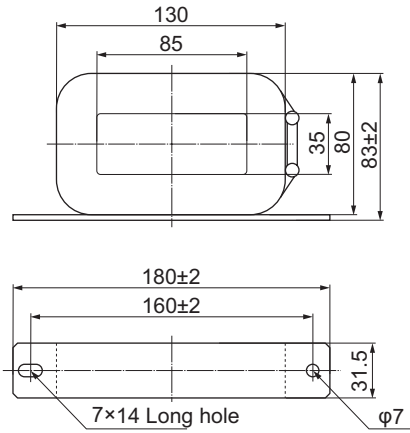

3G3AX-ZCL2

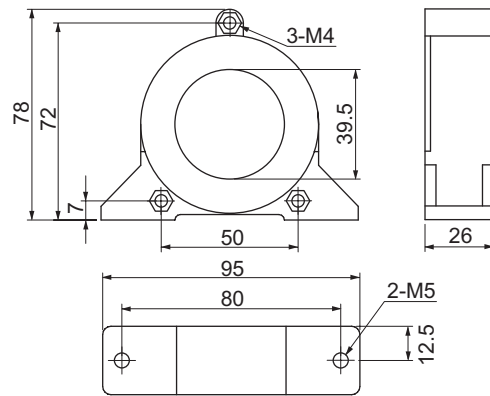

ESD-R-47B

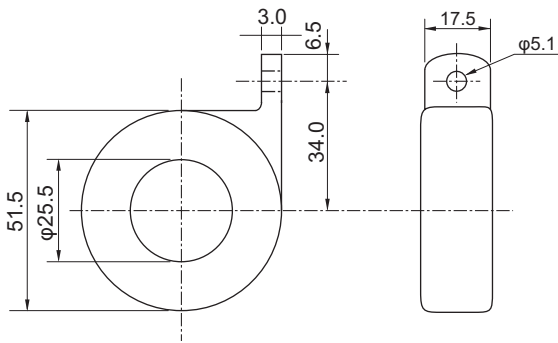

ZCAT3035-1330

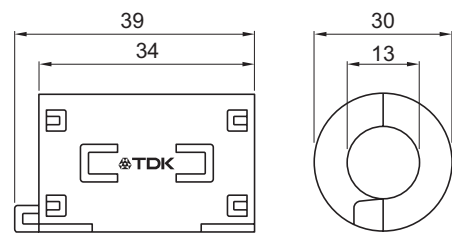

RJ8035/RJ8095

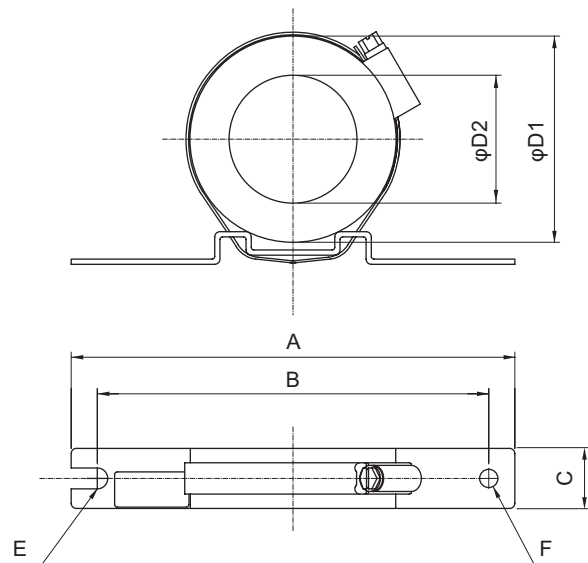

T400-61D

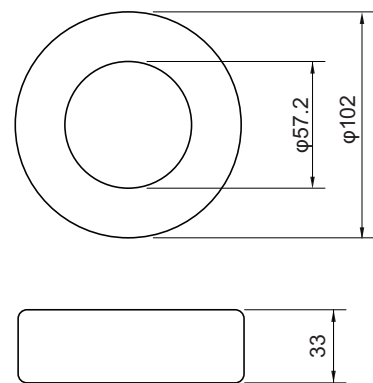

Model	Current value	Dimensions (unit: mm)							
		A	B	C	D1	D2	Core thickness	E	F
RJ8035	35A	170	150	23	80	53	24	R3.5	7
RJ8095	95A	200	180	34	130	107	35	R3.5	7

● Impedance Characteristics

3G3AX-ZCL1

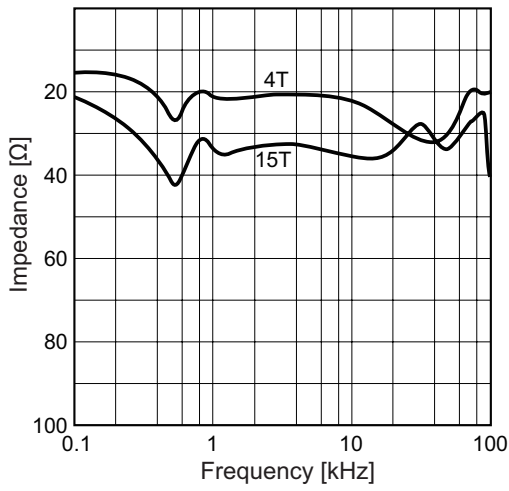

3G3AX-ZCL2

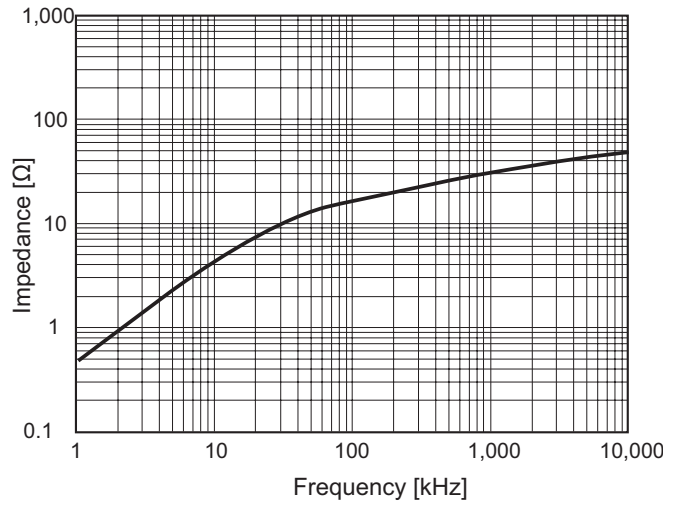

ESD-R-47B

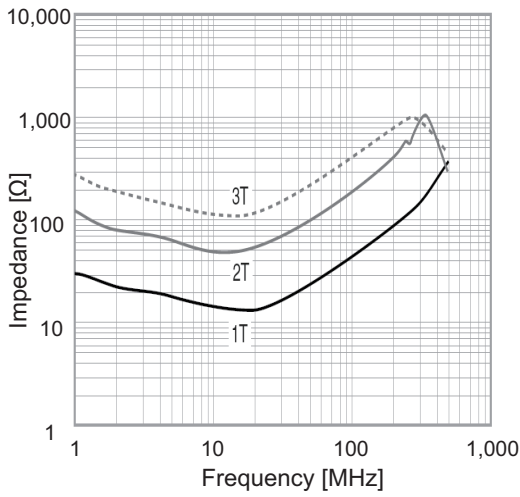

ZCAT3035-1330

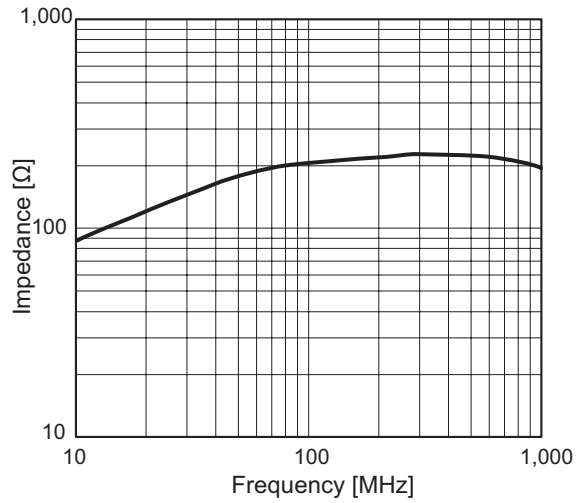

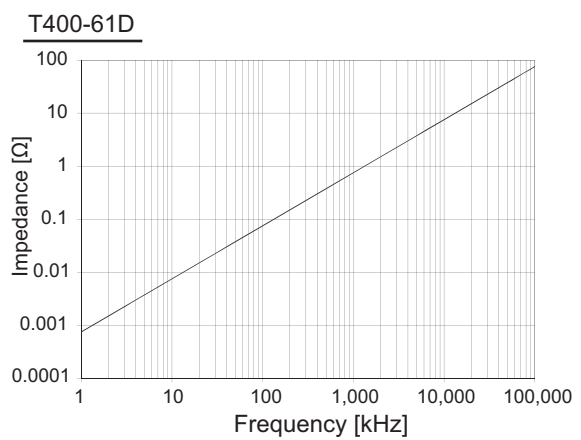
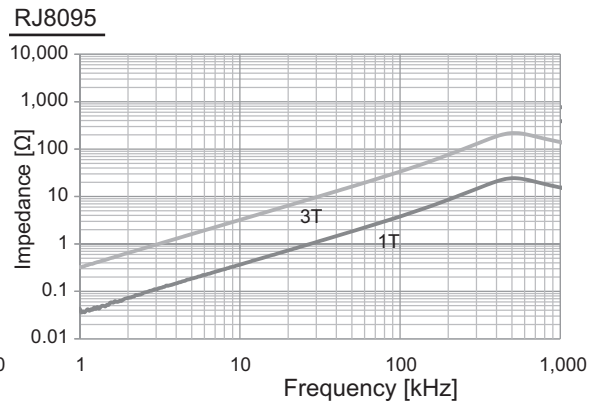
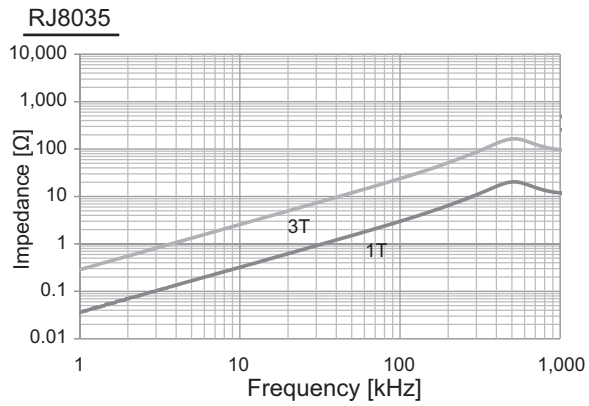

Surge Suppressors

- Install surge suppressors for loads that have induction coils, such as relays, solenoids, brakes, clutches, etc.
- The following table shows the types of surge suppressors and recommended products.

Type	Feature	Recommended product
Diodes	Diodes are used for relatively small loads such as relays when the reset time is not a critical issue. At power shutoff the surge voltage is the lowest, but the reset time takes longer. Used for 24/48-VDC systems.	Use a fast-recovery diode with a short reverse recovery time. (e.g. RU2 of Sanken Electric Co., Ltd.)
Thyristors and varistors	Thyristors and varistors are used for loads when induction coils are large, as in electromagnetic brakes, solenoids, etc., and when reset time is critical. The surge voltage at power shutoff is approximately 1.5 times the varistor voltage.	Select the varistor voltage as follows. 200-VAC systems: varistor voltage 470 V
Capacitor + resistor	The capacitor plus resistor combination is used to absorb vibration in the surge at power supply shutoff. The reset time can be shortened by selecting the appropriate capacitance and resistance.	Okaya Electric Industries Co., Ltd. XEB12002 0.2 μ F - 120 Ω XEB12003 0.3 μ F - 120 Ω

- Thyristors and varistors are made by the following manufacturers. Refer to manufacturer's documentation for details on these components.

Thyristors: Ishizuka Electronics Co.

Varistors: Ishizuka Electronics Co., Panasonic Corporation

Contactors

- Select contactors based on the circuit's inrush current and the maximum momentary phase current.
- The drive inrush current is covered in the preceding explanation of no-fuse breaker selection. And the maximum momentary phase current is approximately twice the rated current.

Improving Encoder Cable Noise Resistance

Take the following steps during wiring and installation to improve the encoder's noise resistance.

- Always use the specified encoder cables.
- If cables are joined midway, be sure to use connectors. And do not remove more than 50 mm of the cable insulation. In addition, always use shielded cables.
- Do not roll cables. If cables are long and are rolled, mutual induction and inductance will increase and cause malfunctions. Always use cables fully extended.
- When installing noise filters for encoder cables, use clamp cores.
- The following table shows the recommended clamp cores.

Manufacturer	Product name	Model	Specifications
NEC TOKIN	Clamp core	ESD-SR-250	For cable diameter up to 13 mm
TDK	Clamp core	ZCAT3035-1330	For cable diameter up to 13 mm

- Do not place the encoder cable with the following cables in the same duct.
Control cables for brakes, solenoids, clutches, and valves.

External Dimensions

ESD-SR-250

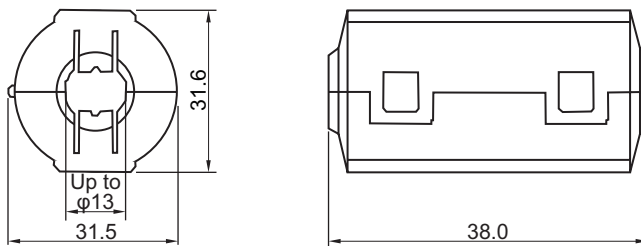

Impedance Characteristics

ESD-SR-250

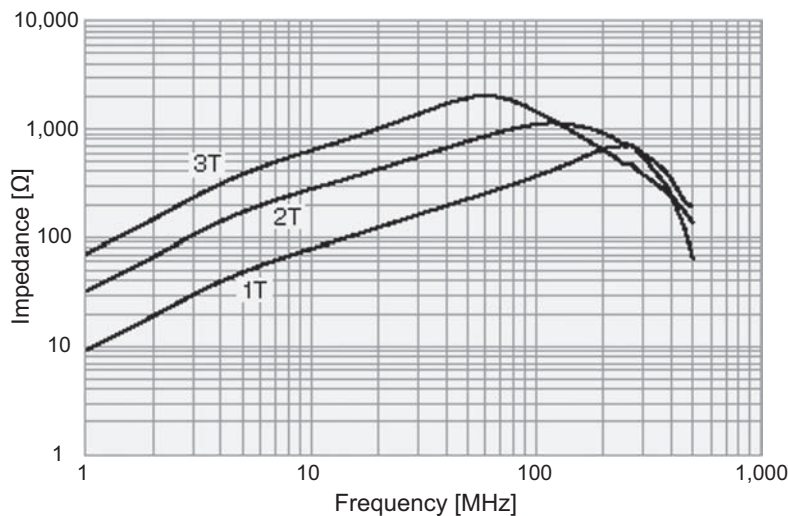

Refer to *External Dimensions* on page 4-30 and *Impedance Characteristics* on page 4-31 for information on the external dimensions and impedance characteristics of the ZCAT3035-1330 clamp core.

Improving Control I/O Signal Noise Resistance

Positional deviation and I/O signal errors can occur if control I/O is influenced by noise.

- Use completely separate power supplies for the control power supply (especially 24 VDC) and the external operation power supply. In particular, do not connect the ground wires for these two power supplies.
- Install a noise filter on the primary side of the control power supply.
- If motors with brake are being used, do not use the same 24-VDC power supply for both the brakes and the control I/O. Additionally, do not connect the ground wires. Connecting the ground wires may cause I/O signal errors.
- Separate the power supply for the pulse command and error counter reset input lines from the control power supply as far apart as possible. In particular, do not connect the ground wires for these two power supplies.
- We recommend using line drivers for the pulse command and error counter reset outputs.
- For the pulse command and error counter reset signal lines, always use shielded twisted-pair cables and connect each end of those shielded cables to the frame ground.
- If the control power supply wiring is long, noise resistance can be improved by adding 1- μ F laminated ceramic capacitors between the control power supply and ground at the drive input section or the controller output section.
- For open-collector specifications, keep the length of wires to within two meters.

Reactor to Reduce Harmonic Current

● Harmonic Current Measures

- Use a Reactor to suppress harmonic currents. The Reactor functions to suppress sudden and quick changes in electric currents.
- Select the proper Reactor model according to the Servo Drive to be used.

Servo Drive model	Reactor			
	Model	Rated current	Inductance	Reactor type
R88D-KP01H (For single-phase input)	3G3AX-DL2002	1.6 A	21.4 mH	DC reactor
R88D-KP02H (For single-phase input)	3G3AX-DL2004	3.2 A	10.7 mH	
R88D-KP04H (For single-phase input)	3G3AX-DL2007	6.1 A	6.75 mH	
R88D-KP08H	3G3AX-DL2015	9.3 A	3.51 mH	
R88D-KP10H (For single-phase input)				
R88D-KP15H (For single-phase input)	3G3AX-DL2022	13.8 A	2.51 mH	
R88D-KP01H	3G3AX-AL2025	10.0 A	2.8 mH	AC reactor
R88D-KP02H				
R88D-KP04H				
R88D-KP08H				
R88D-KP10H				
R88D-KP15H (For 3-phase input)				
R88D-KP20H	3G3AX-AL2055	20.0 A	0.88 mH	
R88D-KP30H				
R88D-KP50H	3G3AX-AL2110	34.0 A	0.35 mH	

Selecting Other Parts for Noise Resistance

This section explains the criteria for selecting the connection components required to improve noise resistance.

Understand each component's characteristics, such as its capacity, performance, and applicable range when selecting the connection components.

For more details, contact the manufacturers directly.

● Noise Filters for Motor Output

- Use noise filters without built-in capacitors on the motor output lines.
- Select a noise filter with a rated current at least twice the Servo Drive's continuous output current.
- The following table shows the noise filters that are recommended for motor output lines.

Manufacturer	Model	Rated current	Comment
OMRON	3G3AX-NF001	6 A	For inverter output
	3G3AX-NF002	12 A	
	3G3AX-NF003	25 A	
	3G3AX-NF004	50 A	
	3G3AX-NF005	75 A	
	3G3AX-NF006	100 A	

Note 1 Motor output lines cannot use the same noise filters for power supplies.

- 2** General noise filters are made for power supply frequencies of 50/60 Hz. If these noise filters are connected to PWM output of the Servo Drive, a very large (about 100 times larger) leakage current may flow through the noise filter's capacitor. This may damage the Servo Drive.

● External Dimensions

● 3G3AX-NF001/-NF002

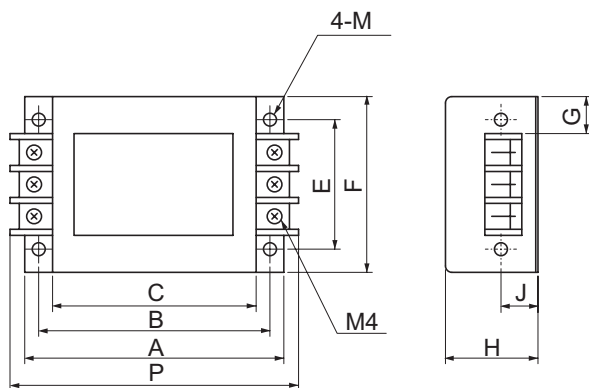

Model	Dimensions [mm]									
	A	B	C	E	F	G	H	J	M	P
3G3AX-NF001	140	125	110	70	95	22	50	20	ø4.5	156
3G3AX-NF002	160	145	130	80	110	30	70	25	ø5.5	176

● 3G3AX-NF003/-NF004/-NF005/-NF006

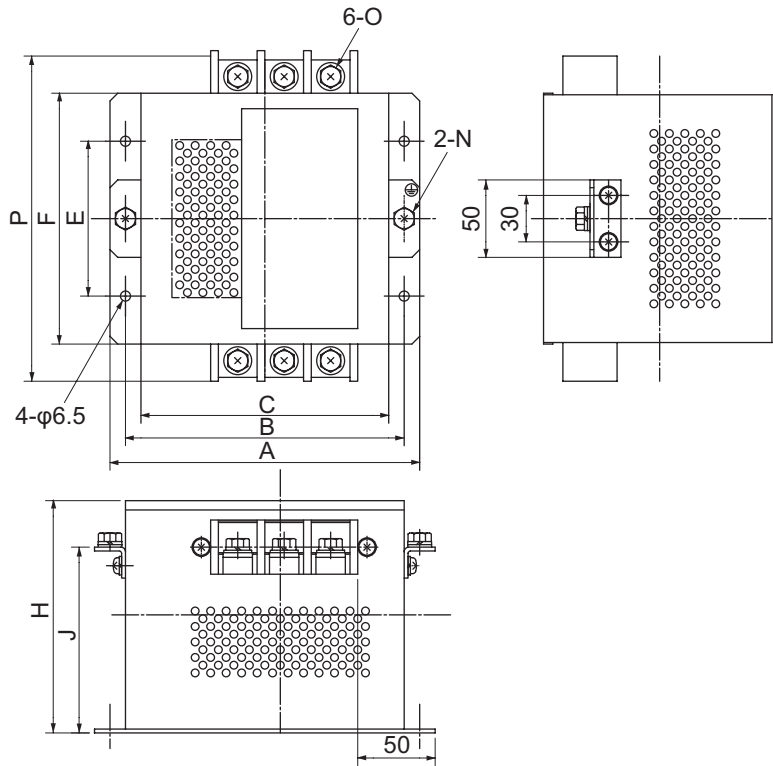

Model	Dimensions [mm]									
	A	B	C	E	F	H	J	N	O	P
3G3AX-NF003	160	145	130	80	112	120	–	–	M4	154
3G3AX-NF004	200	180	160	100	162	150	120	M5	M5	210
3G3AX-NF005	220	200	180	100	182	170	140	M6	M6	230
3G3AX-NF006	220	200	180	100	182	170	140	M8	M8	237

4-4 Regenerative Energy Absorption

The Servo Drives have internal regeneration process circuitry, which absorbs the regenerative energy produced during motor deceleration and prevents the DC voltage from increasing. An overvoltage error occurs, however, if the amount of regenerative energy from the motor is too large. If this occurs, remedies must be taken to reduce the regenerative energy by changing operating patterns, or to increase the regeneration process capacity by connecting an External Regeneration Unit.

4-4-1 Calculating the Regenerative Energy

Horizontal Axis

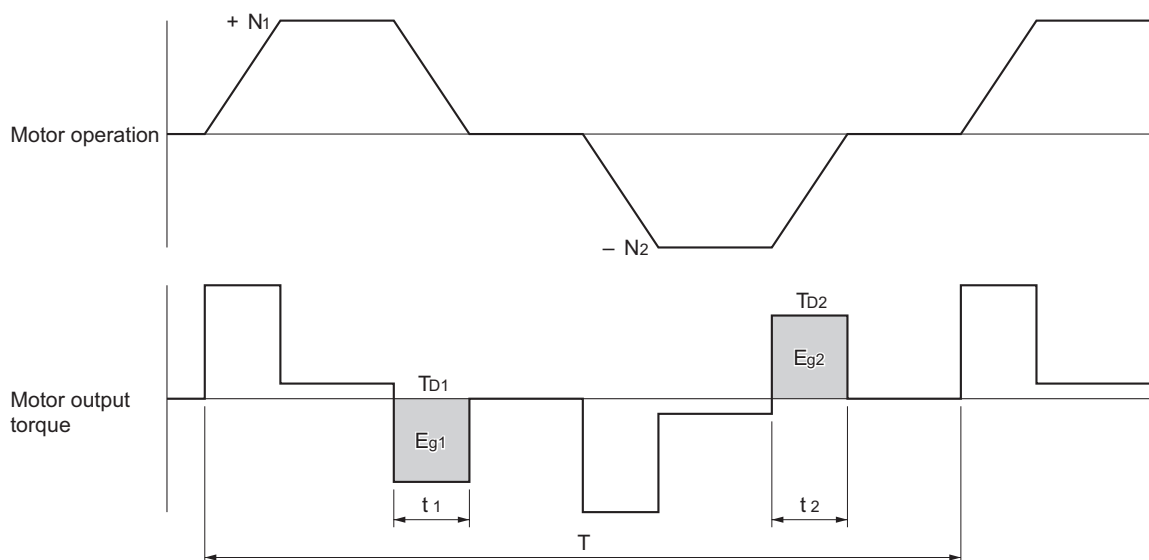

- In the output torque graph, acceleration in the forward direction is shown as positive (+), and acceleration in the reverse direction is shown as negative (-).
- The regenerative energy values in each region can be derived from the following equations.

$$E_{g1} = \frac{1}{2} \cdot \frac{2\pi}{60} \cdot N_1 \cdot T_{D1} \cdot t_1 \quad [\text{J}]$$

$$E_{g2} = \frac{1}{2} \cdot \frac{2\pi}{60} \cdot N_2 \cdot T_{D2} \cdot t_2 \quad [\text{J}]$$

N_1, N_2 : Rotation speed at start of deceleration [r/min]

T_{D1}, T_{D2} : Deceleration torque [N·m]

t_1, t_2 : Deceleration time

Note Due to the loss of motor winding resistance and PWM, the actual regenerative energy will be approximately 90% of the values derived from these equations.

- For Servo Drive models with internal capacitors used for absorbing regenerative energy (i.e., Servo Drive models of 400 W or less), the values E_{g1} and E_{g2} (unit: J) must be lower than the drive's regeneration absorption capacity. (The capacity depends on the model. For details, refer to the next section.)
- For Servo Drive models with an Internal Regeneration Resistor used for absorbing regenerative energy (i.e., Servo Drive models of 500 W or more), the average amount of regeneration P_r (unit: W) must be calculated, and this value must be lower than the drive's regeneration absorption capacity. (The capacity depends on the model. For details, refer to the next section.)

The average regeneration power (P_r) is the regeneration power produced in 1 cycle of operation [W].

$$P_r = (E_{g1} + E_{g2}) / T [\text{W}]$$

T : Operation cycle [s]

Vertical Axis

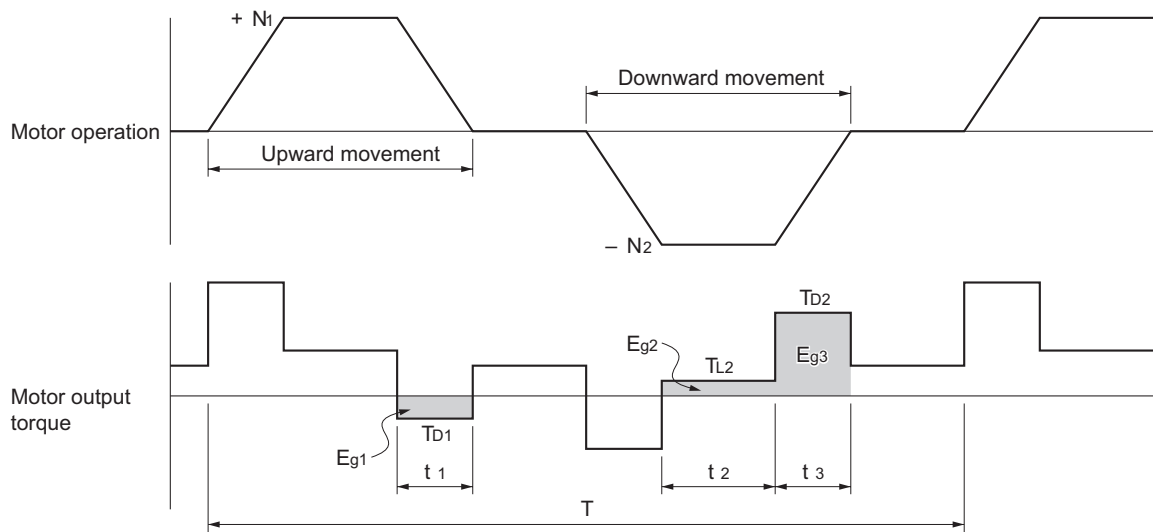

- In the output torque graph, acceleration in the forward direction (rising) is shown as positive (+), and acceleration in the reverse direction (falling) is shown as negative (-).
- The regenerative energy values in each region can be derived from the following equations.

$$E_{g1} = \frac{1}{2} \cdot \frac{2\pi}{60} \cdot N_1 \cdot T_{D1} \cdot t_1 \quad [\text{J}]$$

$$E_{g2} = \frac{2\pi}{60} \cdot N_2 \cdot T_{L2} \cdot t_2 \quad [\text{J}]$$

$$E_{g3} = \frac{1}{2} \cdot \frac{2\pi}{60} \cdot N_2 \cdot T_{D2} \cdot t_3 \quad [\text{J}]$$

N_1, N_2 : Rotation speed at start of deceleration [r/min]

T_{D1}, T_{D2} : Deceleration torque [N·m]

T_{L2} : Torque during downward movement [N·m]

t_1, t_3 : Deceleration time

t_2 : Constant-speed driving time during downward movement [s]

Note Due to the loss of winding resistance, the actual regenerative energy will be approximately 90% of the values derived from these equations.

- For Servo Drive models with internal capacitors used for absorbing regenerative energy (i.e., Servo Drive models of 400 W or less), the values E_{g1} and $E_{g2} + E_{g3}$ (unit: J) must be lower than the drive's regeneration absorption capacity. (The capacity depends on the model. For details, refer to the next section.)
- For Servo Drive models with an Internal Regeneration Resistor used for absorbing regenerative energy (i.e., Servo Drive models of 500 W or more), the average amount of regeneration P_r (unit: W) must be calculated, and this value must be lower than the drive's regeneration absorption capacity. (The capacity depends on the model. For details, refer to the next section.)

The average regeneration power (P_r) is the regeneration power produced in 1 cycle of operation [W].

$$P_r = (E_{g1} + E_{g2} + E_{g3}) / T \quad [\text{W}]$$

T : Operation cycle [s]

4-4-2 Servo Drive Regeneration Absorption Capacity

Amount of Internal Regeneration Absorption in Servo Drives

This Servo Drive absorbs regenerative energy internally with built-in capacitors.

If the regenerative energy is too large to be processed internally, an overvoltage error occurs and operation cannot continue.

The following table shows the regenerative energy (and amount of regeneration) that each drive can absorb. If these values are exceeded, take the following processes.

- Connect an External Regeneration Resistor. (Regeneration process capacity improves.)
- Reduce the operating rotation speed. (The amount of regeneration is proportional to the square of the rotation speed.)
- Lengthen the deceleration time. (Regenerative energy per unit time decreases.)
- Lengthen the operation cycle, i.e., the cycle time. (Average regenerative power decreases.)

Servo Drive model	Regenerative energy to be absorbed by built-in capacitor (J)	Internal regeneration resistor	Allowable minimum regeneration resistance (Ω)
		Average amount of regenerative energy to be absorbed (W)	
R88D-KP01H	18	–	34
R88D-KP02H	18	–	34
R88D-KP04H	26	–	34
R88D-KP08H	46	12	25
R88D-KP10H	74	18	25
R88D-KP15H	74	18	25
R88D-KP20H	74	72	10
R88D-KP30H	113	60	7
R88D-KP50H	113	60	5

4-4-3 Regenerative Energy Absorption with an External Regeneration Resistor

If the regenerative energy exceeds the regeneration absorption capacity of the Servo Drive, connect an External Regeneration Resistor.

Connect the External Regeneration Resistor between B1 and B2 terminals on the Servo Drive.

Double-check the terminal names when connecting the resistor because the drive may be damaged if connected to the wrong terminals.

The temperature of the External Regeneration Resistor will rise up to approximately 120°C. Do not place it near equipment and wiring that is easily affected by heat. Attach radiator plates suitable for the heat radiation conditions.

External Regeneration Resistors

● Characteristics

Model	Resistance value	Nominal capacity	The amount of regeneration absorption for 120 temperature rise	Heat radiation condition	Thermal switch output specifications
R88A-RR08050S	50 Ω	80 W	20 W	Aluminum 350 x 350, Thickness: 3.0	Operating temperature: 150 ± 5°C NC contact Rated output (resistive load): 125 VAC, 0.1 A max. 30 VDC, 0.1 A max. (minimum current: 1 mA)
R88A-RR080100S	100 Ω	80 W	20 W	Aluminum 350 x 350, Thickness: 3.0	Operating temperature: 150 ± 5°C NC contact Rated output (resistive load): 125 VAC, 0.1 A max. 30 VDC, 0.1 A max. (minimum current: 1 mA)
R88A-RR22047S	47 Ω	220 W	70 W	Aluminum 350 x 350, Thickness: 3.0	Operating temperature: 170 ± 7°C NC contact Rated output (resistive load): 250 VAC, 3 A max.
R88A-RR22047S1	47 Ω	220 W	70 W	Aluminum 350 x 350, Thickness: 3.0	Operating temperature: 150 ± 5°C NC contact Rated output (resistive load): 250 VAC, 0.2 A max. 42 VDC, 0.2 A max. (minimum current: 1 mA)
R88A-RR50020S	20 Ω	500 W	180 W	Aluminum 600 x 600, Thickness: 3.0	Operating temperature: 200 ± 7°C NC contact Rated output (resistive load): 250 VAC, 0.2 A max. 42 VDC, 0.2 A max. (minimum current: 1 mA)

4-4-4 Connecting an External Regeneration Resistor

R88D-KP01H/-KP02H/-KP04H

Normally B2 and B3 are open.

If an External Regeneration Resistor is necessary, connect the External Regeneration Resistor between B1 and B2 as shown in the diagram below.

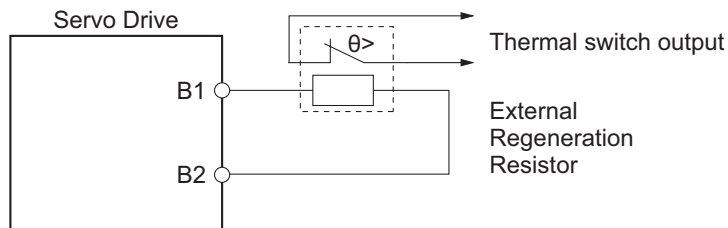

Precautions for Correct Use

Connect the thermal switch output so that the main circuit power supply is shut OFF when the contacts open.

When using multiple External Regeneration Resistors, connect each thermal switch in series. Fire or burn damage may result due to the temperature rise in the resistors if the Servo Drive is used without setting up a power supply shutoff sequence using the output from the thermal switch.

R88D-KP08H/-KP10H/-KP15H/-KP20H/-KP30H/-KP50H/

Normally B2 and B3 are shorted.

If an External Regeneration Resistor is necessary, remove the short-circuit bar between B2 and B3, and then connect the External Regeneration Resistor between B1 and B2 as shown in the diagram below.

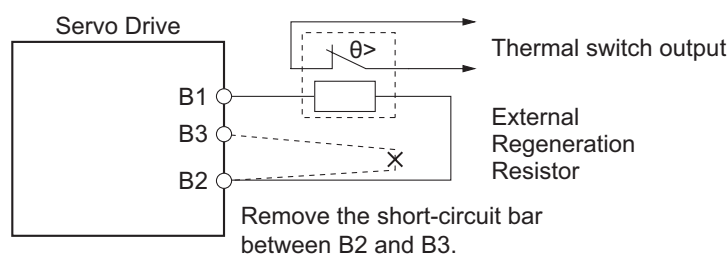



Precautions for Correct Use

Connect the thermal switch output so that the main circuit power supply is shut OFF when the contacts open.

When using multiple External Regeneration Resistors, connect each thermal switch in series. Fire or burn damage may result due to the temperature rise in the resistors if the Servo Drive is used without setting up a power supply shutoff sequence using the output from the thermal switch.

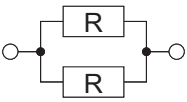
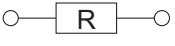
● Combining External Regeneration Resistors

Regeneration absorption capacity ^{*1}	20 W	40 W	70 W	140 W
Model	R88A-RR08050S R88A-RR080100S	R88A-RR08050S R88A-RR080100S	R88A-RR22047S R88A-RR22047S1	R88A-RR22047S R88A-RR22047S1
Resistance value ^{*2}	50 Ω /100 Ω	25 Ω /50 Ω	47 Ω	94 Ω
Connection method				

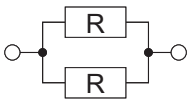
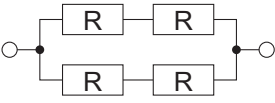
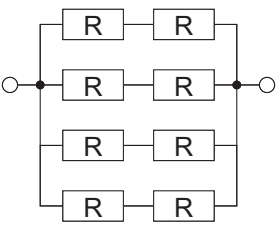
Regeneration absorption capacity ^{*1}	140 W	280 W	560 W
Model	R88A-RR22047S R88A-RR22047S1	R88A-RR22047S R88A-RR22047S1	R88A-RR22047S R88A-RR22047S1
Resistance value ^{*2}	23.5 Ω	47 Ω	23.5 Ω
Connection method			

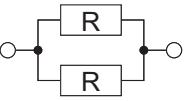
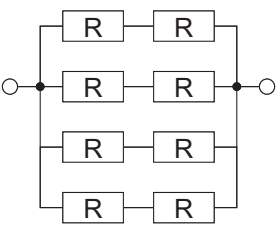
Regeneration absorption capacity ^{*1}	180 W	360 W	1,440 W
Model	R88A-RR50020S	R88A-RR50020S	R88A-RR50020S
Resistance value ^{*2}	20 Ω	10 Ω	10 Ω
Connection method			

*1 Select a combination that has an absorption capacity greater than the average regeneration power (Pr).

*2 Do not use a combination with resistance values lower than the allowable minimum regeneration resistance of each drive. For information on the allowable minimum regeneration resistance, refer to 4-4-2 Servo Drive Regeneration Absorption Capacity on page 4-41.



Precautions for Safe Use

Surface temperatures on regeneration resistance can reach 200°C. Do not place objects that tend to catch fire nearby. To prevent people from touching them, install a cover that enables heat dissipation.

5

Basic Control Mode

This section provides the outline of functions and settings for each control mode.

5-1	Position Control	5-2
5-1-1	Outline of the Function	5-2
5-1-2	Parameters Requiring Settings	5-3
5-1-3	Related Functions	5-5
5-1-4	Parameter Block Diagram for Position Control Mode	5-6
5-2	Internally Set Speed Control	5-7
5-2-1	Outline of the Function	5-7
5-2-2	Parameters Requiring Settings	5-7
5-2-3	Related Functions	5-11
5-2-4	Parameter Block Diagram for Speed Control Mode	5-12
5-3	Switching Control	5-13
5-3-1	Outline of the Function	5-13
5-3-2	Parameters Requiring Settings	5-13
5-3-3	Related Functions	5-14

5-1 Position Control

5-1-1 Outline of the Function

- The position control function performs position control according to the pulse-train input from the controller.
- The motor rotates based on the value of the pulse-train input multiplied by the electronic gear setting (Pn008 to Pn010).

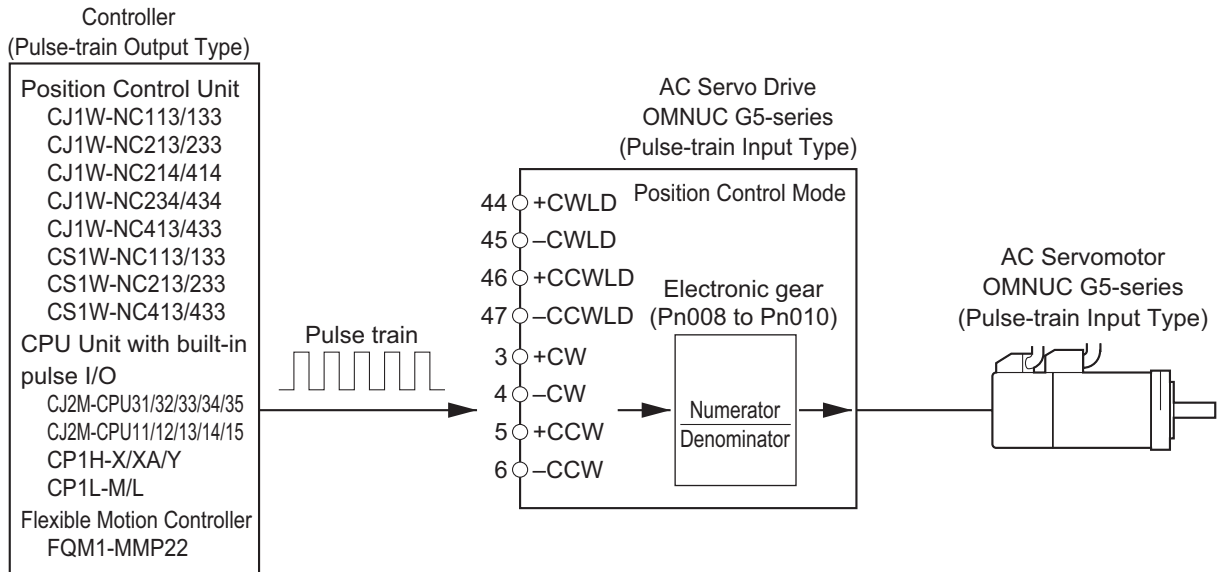

5-1-2 Parameters Requiring Settings

Parameter No.	Name	Description	Reference
Pn001	Control Mode Selection	Select the control mode.	P.7-3
Pn005	Command Pulse Input Selection	Select the command pulse input terminal.	P.7-4
Pn006	Command Pulse Rotation Direction Switching Selection	Set the count direction for the command pulse input.	P.7-4
Pn007	Command Pulse Mode Selection	Set the count method for the command pulse input.	P.7-5
Pn009	Electronic Gear Ratio Numerator 1	Set the numerator of the electronic gear ratio for the command pulse input.	P.7-7
Pn010	Electronic Gear Ratio Denominator	Set the denominator of the electronic gear ratio for the command pulse input.	P.7-7

Control Mode Selection (Pn001)

Select the position control mode (Set value: 0 or 3).

Command Pulse Input Process (Pn005, Pn006, Pn007)

Position command input terminals are divided into two channels: input 1 (+CW, -CW, +CCW, -CCW) and input 2 (+CWLD, -CWLD, +CCWLD, -CCWLD). If the position command output is for line driver output, select input 1. If it is for open collector output, select input 2. Although input 2 can also be used for line driver output, its maximum allowable input frequency is lower than that of input 1.

Parameter No.	Name	Description	Setting range	Unit
Pn005	Command Pulse Input Selection	Select the command pulse input terminal. 0: Photocoupler input (+CW, -CW, +CCW, -CCW) 1: Input for line driver only (+CWLD, -CWLD, +CCWLD, -CCWLD)	0 to 1	—
Pn006	Command Pulse Rotation Direction Switching Selection	Set the count direction for the command pulse input. 0: Command pulse, forward direction 1: Command pulse, reverse direction	0 to 1	—
Pn007	Command Pulse Mode Selection	Set the count method for the command pulse input. 0: 90° phase difference (A/B) signal input 1: Forward pulse/Reverse pulse 2: 90° phase difference (A/B) signal input 3: Feed pulse/Forward or reverse signal	0 to 3	—

Command Pulse Rotation Direction Switching Selection and Command Pulse Mode Selection settings are as follows.

Pn006	Pn007	Command pulse pattern	Signal	Forward direction command	Reverse direction command
0	0 or 2	90° phase difference 2-phase pulse (Phase A and Phase B)	PULS		
			SIGN		
	1	Forward direction pulse train + Reverse direction pulse train	PULS		
			SIGN		
	3	Pulse train + Sign	PULS		
			SIGN		
1	0 or 2	90° phase difference 2-phase pulse (Phase A and Phase B)	PULS		
			SIGN		
	1	Forward direction pulse train + Reverse direction pulse train	PULS		
			SIGN		
	3	Pulse train + Sign	PULS		
			SIGN		

Symbol		Maximum allowable input frequency	Minimum required duration [μs]					
			t1	t2	t3	t4	t5	t6
+CWLD, -CWLD, +CCWLD, -CCWLD		4 Mpps	0.25	0.125	0.125	0.125	0.125	0.125
+CW, -CW, +CCW, -CCW	Line driver	500 kpps	2	1	1	1	1	1
	Open collector	200 kpps	5	2.5	2.5	2.5	2.5	2.5

Electronic Gear Function (Pn008, Pn009, Pn010)

The electronic gear function enables to multiply the pulse command input from the host controller by the specified gear ratio to determine the position command to the position control.

Parameter No.	Name	Description	Setting range	Unit
Pn008	Electronic Gear Integer Setting	Set the number of command pulses per motor rotation.	0 to 2^{20}	Pulse
Pn009	Electronic Gear Ratio Numerator 1	Set the numerator of the electronic gear ratio for the command pulse input.	0 to 2^{30}	–
Pn010	Electronic Gear Ratio Denominator	Set the denominator of the electronic gear ratio for the command pulse input.	1 to 2^{30}	–

- For details about the electronic gear function, refer to *6-4 Electronic Gear Function* on page 6-11.

5-1-3 Related Functions

Parameter No.	Name	Description	Reference
Pn008	Electronic Gear Integer Setting	Set the number of command pulses per motor rotation.	P.7-7
Pn011	Encoder Dividing Numerator	Set the pulse output resolution using the numbers of output pulses per rotation for phase A and phase B, respectively.	P.7-8
Pn012	Encoder Output Direction Switching Selection	Set the combination of the phase-B logic and the output source for pulse output.	P.7-8
Pn222	Position Command Filter Time Constant	Set the time constant of the first-order lag filter for the position command.	P.7-24
Pn223	Smoothing Filter Time Constant	Set the time constant of the FIR filter for the position command.	P.7-25
Pn431	Positioning Completion Range 1	Set the threshold for the position error at which the Positioning Completion Signal is output.	P.7-37
Pn432	Positioning Completion Condition Selection	Select the condition under which the Positioning Completion Signal is output.	P.7-37
Pn433	Positioning Completion Hold Time	Set the INP signal output duration.	P.7-37
Pn503	Encoder Dividing Denominator	Set the dividing ratio by using Encoder Dividing Numerator (Pn011) as the dividing numerator and Encoder Dividing Denominator (Pn503) as the dividing denominator.	P.7-42
Pn517	Error Counter Reset Condition Selection	Set the condition for resetting the Error Counter Reset input signal.	P.7-49
Pn518	Command Pulse Prohibition Input Setting	Set whether to enable or disable the Command Pulse Prohibition Input.	P.7-50

5-1-4 Parameter Block Diagram for Position Control Mode

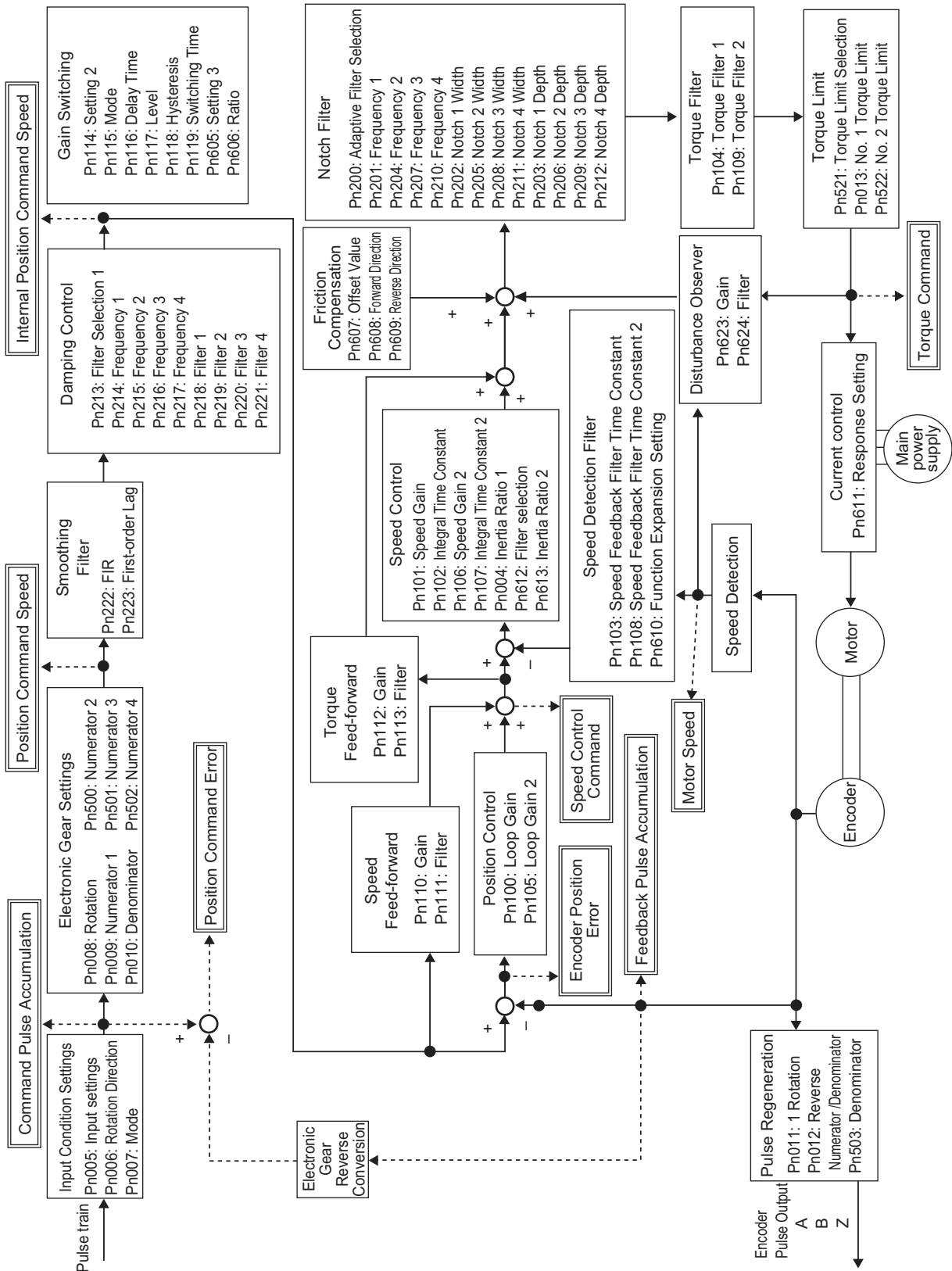

- This timing chart shows an example of push-motion operation with a constant force (torque).

5-2 Internally Set Speed Control

5-2-1 Outline of the Function

- The Internally Set Speed Control function controls the speed of the Servomotor based on the speeds set in the No. 1 to 8 Internally Speed Settings.
- Select the internally set speed using Internally Set Speed Selection 1 to 3 of the control input terminals (VSEL1: CN1 pin 33, VSEL2: CN1 pin 30, VSEL3: CN1 pin 28).

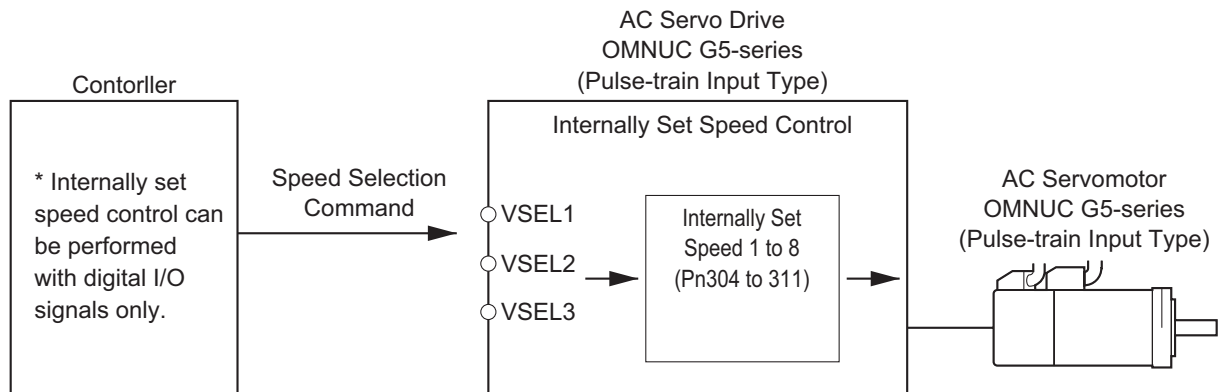

5-2-2 Parameters Requiring Settings

Parameter No.	Name	Description	Reference
Pn001	Control Mode Selection	Select the control mode in which the Internally Set Speed Control function can be used. (Set value: 1, 3)	P.7-3
Pn300	Command speed Selection	Select the speed command input method.	P.7-26
Pn304	No. 1 Internally Set Speed	Set the internally set speeds [r/min]. The valid setting range is from -20,000 to 20,000 r/min. Be sure to set the speeds within the allowable range of rotation speed of the motor.	P.7-27
Pn305	No. 2 Internally Set Speed		
Pn306	No. 3 Internally Set Speed		
Pn307	No. 4 Internally Set Speed		
Pn308	No. 5 Internally Set Speed		
Pn309	No. 6 Internally Set Speed		
Pn310	No. 7 Internally Set Speed		
Pn311	No. 8 Internally Set Speed		
Pn312	Soft Start Acceleration Time	Set the acceleration time for Internally Set Speed Control. Set the time until the Servomotor reaches 1,000 r/min.	P.7-28
Pn313	Soft Start Deceleration Time	Set the deceleration time for Internally Set Speed Control. Set the time until the Servomotor reaches 1,000 r/min.	P.7-28
Pn314	S-curve Acceleration/Deceleration Time Setting	Set the S-curve time in the time width centered on the inflection points for acceleration and deceleration.	P.7-28

Internally Set Speed Selection

The following tables show the internally set speeds that are set with VSEL1, VSEL2 and VSEL3 (internally set speed selection 1, 2 and 3).

● Pn300 = 1

No.	VSEL1	VSEL2	VSEL3	Set speed
0	OFF	OFF	Disabled	Pn304
1	ON	OFF	Disabled	Pn305
2	OFF	ON	Disabled	Pn306
3	ON	ON	Disabled	Pn307

● Pn300 = 3

No.	VSEL1	VSEL2	VSEL3	Set speed
0	OFF	OFF	OFF	Pn304
1	ON	OFF	OFF	Pn305
2	OFF	ON	OFF	Pn306
3	ON	ON	OFF	Pn307
4	OFF	OFF	ON	Pn308
5	ON	OFF	ON	Pn309
6	OFF	ON	ON	Pn310
7	ON	ON	ON	Pn311

Operation Example

- Internally set speed control with 4 speed changes when Pn300 is set to 1

Operation Command (RUN)

Zero Speed Specified (VZERO)

Internally Set Speed Selection 1 (VSEL1)

Internally Set Speed Selection 2 (VSEL2)

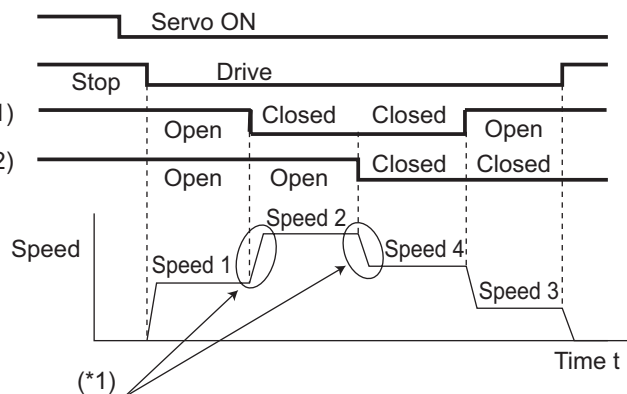

- *1 The acceleration time, deceleration time, and S-curve acceleration/deceleration time can be set in parameters Pn312, Pn313, and Pn314, respectively.



Precautions for Correct Use

If more than one internally set speed selection signal is switched at the same time (e.g., as when switching from Speed 2 to Speed 3), an internally set speed signal in the process of switching may be temporarily selected. (For example, Speed 1 or Speed 4 may be temporarily selected.)

The internally set speed command may be temporarily performed with a sudden change, especially if the acceleration or deceleration time is set to 0 or small value, or if the speed difference between internally set speed commands is large. Use this function with the following precautions.

- Avoid switching more than one internally set speed selection signal at the same time.
- Set both Soft Start Acceleration Time and Soft Start Deceleration Time so that the speed changes gradually and avoid a sudden change.

Internal Speed Command (Pn304 to Pn311)

The internal speed command controls the motor speed according to the internal speed command value set in the parameter.

The internally set speed is enabled when Command Speed Selection (Pn300) is set to 1 or 3.

Up to eight internally set speeds can be set.

Parameter No.	Name	Description	Setting range	Unit
Pn304	No. 1 Internally Set Speed	Set the first internally set speed.	-20,000 to 20,000	r/min
Pn305	No. 2 Internally Set Speed	Set the second internally set speed.	-20,000 to 20,000	r/min
Pn306	No. 3 Internally Set Speed	Set the third internally set speed.	-20,000 to 20,000	r/min
Pn307	No. 4 Internally Set Speed	Set the fourth internally set speed.	-20,000 to 20,000	r/min
Pn308	No. 5 Internally Set Speed	Set the fifth internally set speed.	-20,000 to 20,000	r/min
Pn309	No. 6 Internally Set Speed	Set the sixth internally set speed.	-20,000 to 20,000	r/min
Pn310	No. 7 Internally Set Speed	Set the seventh internally set speed.	-20,000 to 20,000	r/min
Pn311	No. 8 Internally Set Speed	Set the eighth internally set speed.	-20,000 to 20,000	r/min

Speed Command Acceleration/Deceleration Setting Function (Pn312, Pn313, Pn314)

With a step speed command, the speed command can be changed based on the setting to reduce the shock caused by change in acceleration.

Parameter No.	Name	Description	Setting range	Unit
Pn312	Soft Start Acceleration Time	Set the acceleration time for the speed command input.	0 to 10,000	ms/ (1,000 r/min)
Pn313	Soft Start Deceleration Time	Set the deceleration time for the speed command input.	0 to 10,000	ms/ (1,000 r/min)
Pn314	S-curve Acceleration/Deceleration Time Setting	Set the first internal speed.	0 to 1,000	ms

● Soft Start Acceleration Time (Pn312) and Soft Start Deceleration Time (Pn313)

For a step speed command input, set the time until the command speed reaches 1,000 r/min in Soft Start Acceleration Time (Pn312). Similarly, set the time until the command speed slows from 1,000 r/min down to 0 r/min in Soft Start Deceleration Time (Pn313).

$$\text{Soft Start Acceleration Time [ms]} = Vc/1,000 \times Pn312 \times 1 \text{ ms}$$

$$\text{Soft Start Deceleration Time [ms]} = Vc/1,000 \times Pn313 \times 1 \text{ ms}$$

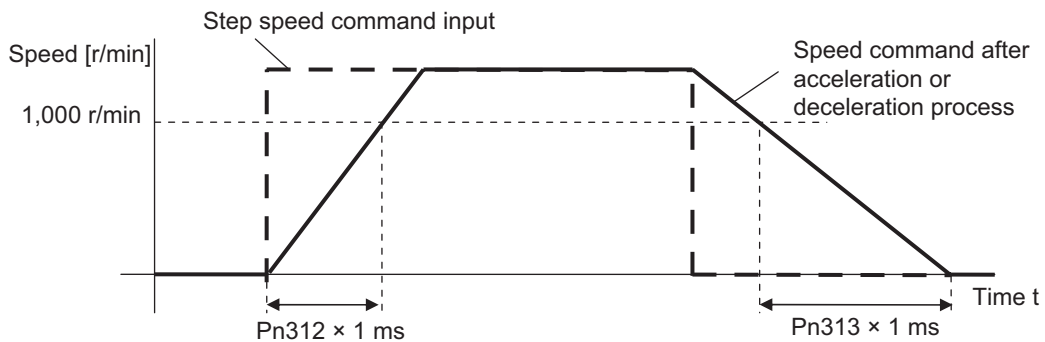

● S-curve Acceleration/Deceleration Time Setting (Pn314)

Set the S-curve time in the time width centered on the inflection points in acceleration/deceleration relative to the acceleration or deceleration time set in Soft Start Acceleration Time (Pn312) or Soft Start Deceleration Time (Pn313).

$$t_a = V_c / 1,000 \times Pn312 \times 1 \text{ ms}$$

$$t_d = V_c / 1,000 \times Pn313 \times 1 \text{ ms}$$

$$t_s = Pn314 \times 1 \text{ ms}$$

Here, t_a must be greater than t_s and t_d must be greater than t_s .

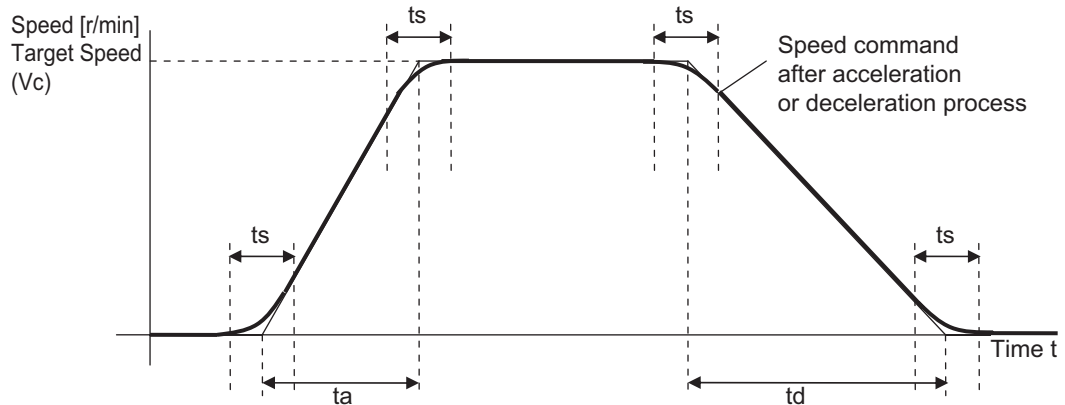

5-2-3 Related Functions

Parameter No.	Name	Description	Reference
Pn315	Zero Speed Designation Selection	Set the zero speed designation selection.	P.7-29
Pn316	Position Lock Level Setting	Set the threshold for transition to the position control servo lock mode.	P.7-30
Pn435	Speed Conformity Detection Range	Set the threshold for detecting the speed conformity output. If the difference between the speed command and the motor speed is equal to or less than the set threshold, the speed conformity output will be output. This setting has a hysteresis of 10 r/min for detection.	P.7-38
Pn436	Rotation Speed for Motor Rotation Detection	Set the threshold for detecting the motor rotation speed detection output. If the motor speed exceeds the set value, the motor rotation speed detection output will be output. This setting has a hysteresis of 10 r/min for detection.	P.7-39

5-2-4 Parameter Block Diagram for Speed Control Mode

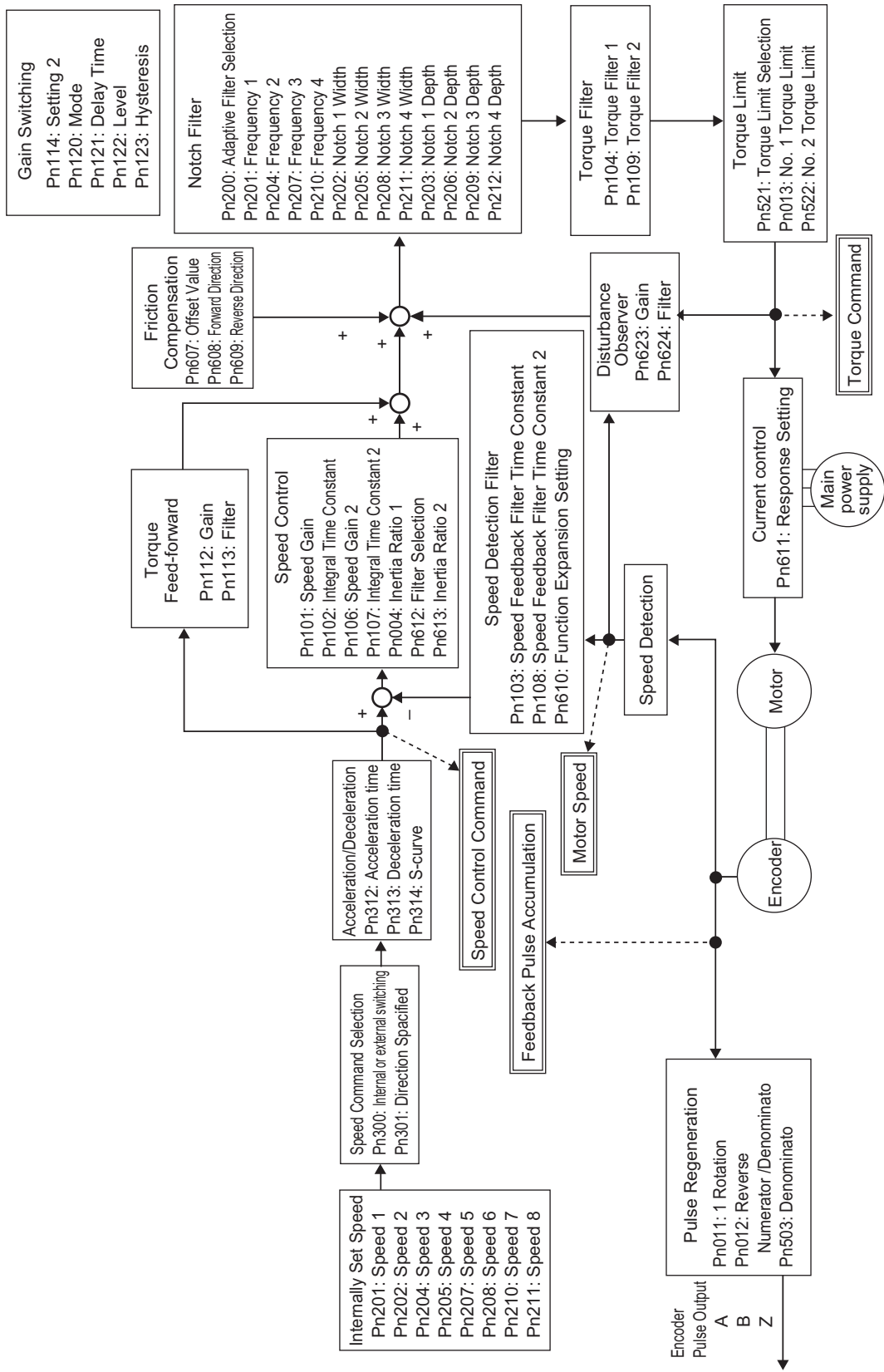

5-3 Switching Control

5-3-1 Outline of the Function

- The switching control function controls the motor by switching between two control modes via external inputs.
- Control mode switching is performed by the control mode switching input (TVSEL: CN1 pin 32).

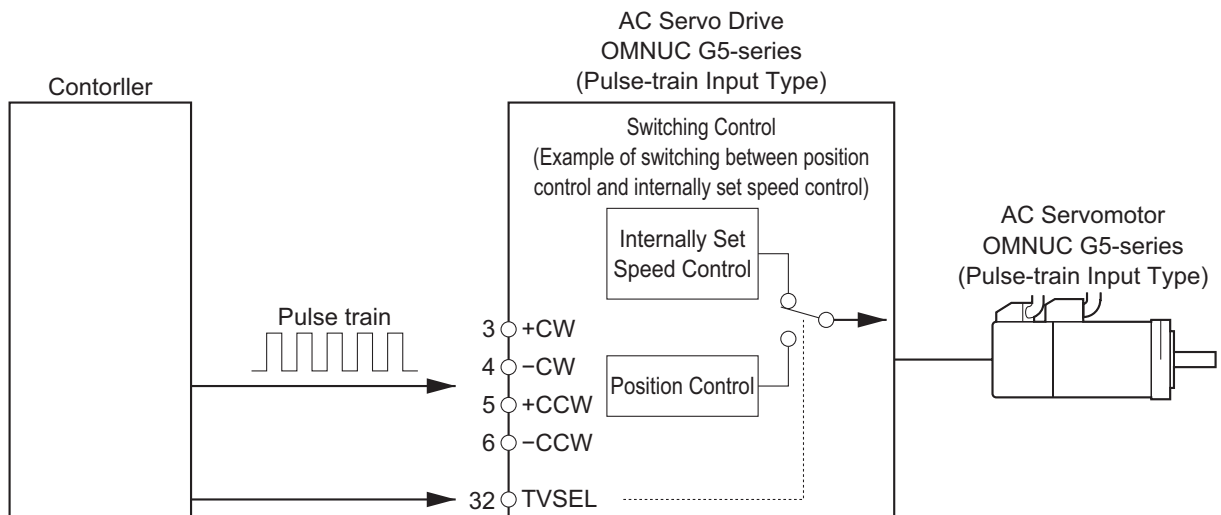

5-3-2 Parameters Requiring Settings

Parameter No.	Name	Description	Reference
Pn001	Control Mode Selection	Select the control mode in which the switching control function can be used. (Set value: 3)	P.7-3

Control Mode Selected by TVSEL (Control Mode Switching Input)

- The following table shows the relation between TVSEL (control mode switching input) and the selected control mode.

Control Mode Selection (Pn001) set value	TVSEL	
	When OFF	When ON
3	Position control	Speed control

Note Be careful when switching the control mode. The operation of the Servomotor may change suddenly depending on the control mode setting.

Operation Example

● When Switching between Position Control and Speed Control (Pn001 = 3)

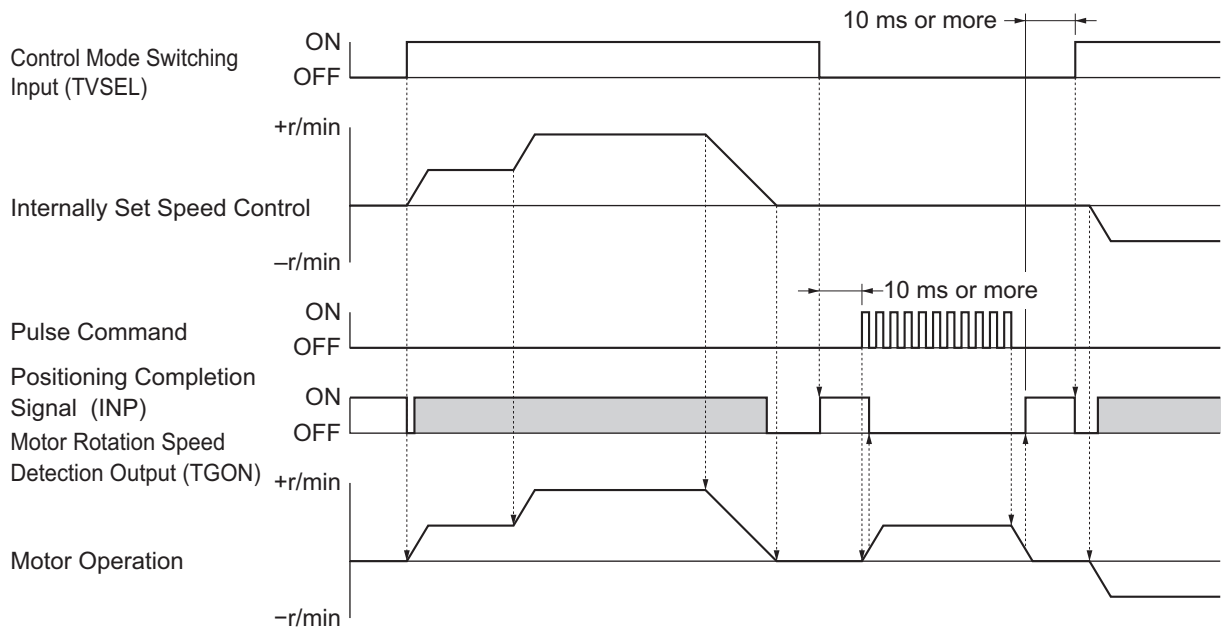

- There is a delay of 10 ms or less in reading the input signal.
- When switching the control mode from speed control to position control, turn OFF the Control Mode Switching Input (TVSEL) and wait at least 10 ms after the Positioning Completion Signal (INP) turns ON, and then input the pulse command. Pulses input before INP turns ON will be ignored.
- The shaded areas for the Positioning Completion Signal (INP) in the time chart show that the signal is turned ON as the motor rotation speed detection output (TGON). (The meaning of the signal varies with the control mode.)

5-3-3 Related Functions

For related functions, refer to the description of each control mode.

6

Applied Functions

This section provides the outline and settings of the applied functions, such as damping control, electronic gear, gain switching, and disturbance observer.

6-1 Damping Control	6-3
6-1-1 Outline of the Function	6-3
6-1-2 Parameters Requiring Settings	6-3
6-2 Adaptive Filter	6-6
6-2-1 Outline of the Function	6-6
6-2-2 Parameters Requiring Settings	6-7
6-3 Notch Filters	6-8
6-3-1 Outline of the Function	6-8
6-3-2 Parameters Requiring Settings	6-9
6-4 Electronic Gear Function	6-11
6-4-1 Outline of the Function	6-11
6-4-2 Parameters Requiring Settings	6-11
6-4-3 Operation Example	6-13
6-5 Encoder Dividing Function	6-15
6-5-1 Outline of the Function	6-15
6-5-2 Parameters Requiring Settings	6-15
6-6 Brake Interlock	6-18
6-6-1 Outline of the Function	6-18
6-6-2 Parameters Requiring Settings	6-18
6-6-3 Precautions for Correct Use of Holding Brake	6-18
6-6-4 Operation	6-19
6-7 Gain Switching Function	6-23
6-7-1 Outline of the Function	6-23
6-7-2 Parameters Requiring Settings	6-24
6-8 Torque Limit	6-31
6-8-1 Outline of the Function	6-31
6-9 Sequence I/O Signals	6-33
6-9-1 Outline of the Function	6-33
6-9-2 Input Signals	6-33
6-9-3 Output Signals	6-36

6-10 Forward and Reverse Drive Prohibition Functions	6-38
6-10-1 Outline of the Function	6-38
6-10-2 Parameters Requiring Settings	6-38
6-11 Disturbance Observer Function	6-41
6-11-1 Outline of the Function	6-41
6-11-2 Parameters Requiring Settings	6-42
6-11-3 Operating Procedure	6-42
6-12 Gain 3 Switching Function	6-43
6-12-1 Outline of the Function	6-43
6-12-2 Parameters Requiring Settings	6-43
6-12-3 Operation	6-43
6-13 Friction Torque Compensation Function	6-44
6-13-1 Outline of the Function	6-44
6-13-2 Parameters Requiring Settings	6-44
6-13-3 Operation Example	6-45
6-14 Inertia Ratio Switching Function	6-46
6-14-1 Outline of the Function	6-46
6-14-2 Parameters Requiring Settings	6-46
6-14-3 Operating Procedure	6-46
6-15 Feed-forward Function	6-47
6-15-1 Outline of the Function	6-47
6-15-2 Parameters Requiring Settings	6-47
6-15-3 Operating Procedure	6-48
6-16 Instantaneous Speed Observer Function	6-50
6-16-1 Outline of the Function	6-50
6-16-2 Parameters Requiring Settings	6-50
6-16-3 Operating Procedure	6-51

6-1 Damping Control

6-1-1 Outline of the Function

If the tip of the mechanical unit vibrates, you can use the damping control function to reduce vibration. This is effective on vibration generated by a low-rigidity machine. The applicable frequencies are from 1 to 200 Hz.

Since the damping control is performed using the position command, it cannot be used with the speed control.

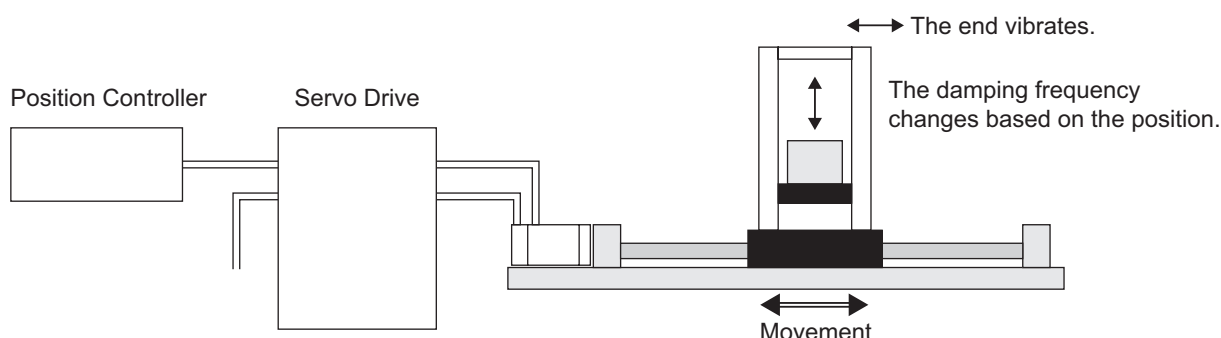

6-1-2 Parameters Requiring Settings

Parameter No.	Name	Description	Reference
Pn001	Control Mode Selection	Set to the position control mode. 0: Position control 3: Control mode 1 of position/speed control	P.7-3
Pn213	Damping Filter Selection	Select the damping filter selection mode according to the condition of the unit. 0: Damping filters 1 and 2 enabled 1: Switching via external input (DFSEL1) 2: Switching via external input (DFSEL1, DFSEL2) 3: Switching based on the command direction	P.7-22
Pn214	Damping Frequency 1	Set Damping Frequency 1 to suppress vibration at the end of the load in damping control. If the damping control function is not used, set the damping frequency to 0.	P.7-22
Pn215	Damping Filter 1 Setting	When Damping Frequency 1 (Pn214) is set, reduce this setting if torque saturation occurs or increase this setting to improve the operation speed. Normally 0 is set. If Damping Filter 1 is disabled, this parameter is also disabled.	P.7-22
Pn216	Damping Frequency 2	The function is the same as Pn214.	P.7-22
Pn217	Damping Filter 2 Setting	The function is the same as Pn215.	P.7-23
Pn218	Damping Frequency 3	The function is the same as Pn214.	P.7-23
Pn219	Damping Filter 3 Setting	The function is the same as Pn215.	P.7-23
Pn220	Damping Frequency 4	The function is the same as Pn214.	P.7-23
Pn221	Damping Filter 4 Setting	The function is the same as Pn215.	P.7-23



Precautions for Correct Use

- Stop operation before changing the parameters or switching with DFSEL.
- Damping control may not function properly or have a poor effect under the following conditions.

Item	Conditions that interfere with the effect of damping control
Control mode	<ul style="list-style-type: none"> • Speed control mode
Load condition	<ul style="list-style-type: none"> • If forces other than position commands, such as external forces, cause vibration • If the damping frequency is outside the range of 1 to 200 Hz • If the ratio of the resonance frequency to anti-resonance frequency is large

Operating Procedure

1 Adjust the position loop gain and the speed loop gain.

Adjust Position Loop Gain (Pn100), Speed Loop Gain (Pn101), Speed Loop Integral Time Constant (Pn102), and Torque Command Filter Time Constant (Pn104).

If no problem occurs in realtime autotuning, you can continue to use the settings.

2 Measure the damping frequency at the tip of the mechanical unit.

Measure the damping frequency by using a measurement device such as a laser displacement sensor, servo acceleration meter, or acceleration pick-up.

Set the measured damping frequency in one of Damping Frequency 1 to Damping Frequency 4 (1: Pn214, 2: Pn216, 3: Pn218, 4: Pn220) according to the operation.

Also set the Switching Mode using Damping Filter Selection (Pn213).

If the measurement device cannot be used, use CX-Drive tracing function, and read the residual damping frequency [Hz] from the position error waveform as shown in the following figure.

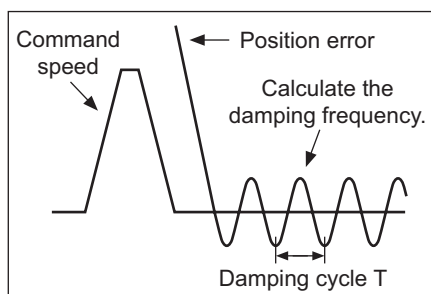

- The damping frequency in the figure is calculated with the following formula:

$$f [\text{Hz}] = \frac{1}{T [\text{s}]}$$

Since the parameter unit is 0.1 Hz:

$$(\text{Pn214, Pn216, Pn218, Pn220}) = 10 \times f$$

- Application example

If the damping cycle is 100 ms or 20 ms, set 100 or 500 in the parameter so that the damping frequency becomes 10 Hz or 50 Hz.

If vibration persists after setting the frequency, increase or decrease the resonance frequency to find a proper frequency at which vibration decreases.

3 Make the damping filter settings.

Make damping filter settings (1: Pn215, 2: Pn217, 3: Pn219, 4: Pn221).

First, set to 0.

The stabilization time can be reduced by setting a large value; however, torque ripple will increase at the command change point as shown in the following figure. Set a range that will not cause torque saturation under actual operation conditions. The effects of vibration suppression will be lost if torque saturation occurs.

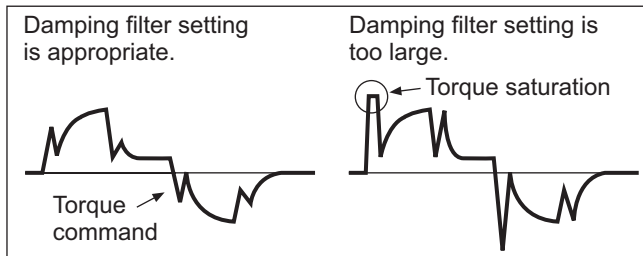

When Damping Frequency 1 (Pn214) is set, reduce this setting if torque saturation occurs or increase this setting to improve the operation speed. Normally 0 is set.

When Damping Filter 1 is enabled, the setting range is as follows:

Setting range: $100 \leq Pn214 + Pn215 \leq Pn214 \times 2$ or 2,000

Note When Damping Filter 1 is disabled in Damping Filter Selection (Pn213), this parameter is also disabled.

4 Set the Damping Filter Selection (Pn213).

Damping Filter 1 to 4 can be switched according to the conditions of the machine vibration.

Set value	Switching mode
0	Damping Filter 1 and 2 enabled
1	Switching via external input (DFSEL1) When DFSEL1 is open: Damping Filter 1 and 3 enabled When DFSEL1 is shorted: Damping Filter 2 and 4 enabled
2	Switching via external input (DFSEL1, DFSEL2) When DFSEL1 and DFSEL2 are open: Damping Filter 1 enabled When DFSEL1 is shorted and DFSEL2 is open: Damping Filter 2 enabled When DFSEL1 is open and DFSEL2 is shorted: Damping Filter 3 enabled When DFSEL1 and DFSEL2 are shorted: Damping Filter 4 enabled
3	Switching based on the command direction During forward rotation: Damping Filter 1 and 3 enabled During reverse rotation: Damping Filter 2 and 4 enabled

6-2 Adaptive Filter

6-2-1 Outline of the Function

The adaptive filter reduces resonance point vibration by estimating the resonance frequency from the vibration component that appears in the motor speed during actual operation and automatically sets the frequency of the notch filter, which removes the resonance component from the torque command.

The automatically set notch filter frequency is applied to the Notch 3 (Pn207 to Pn209) and Notch 4 (Pn210 to Pn212) settings.

Refer to 6-3 *Notch Filters* on page 6-8 for information on notch filter.

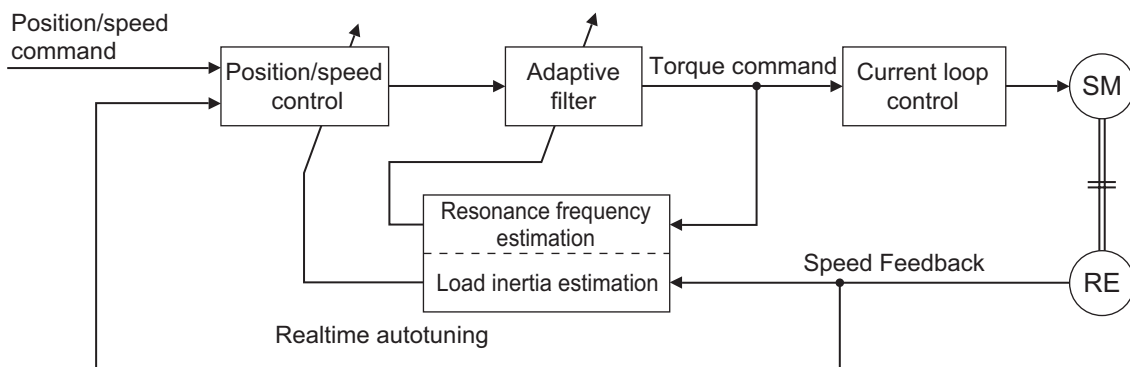
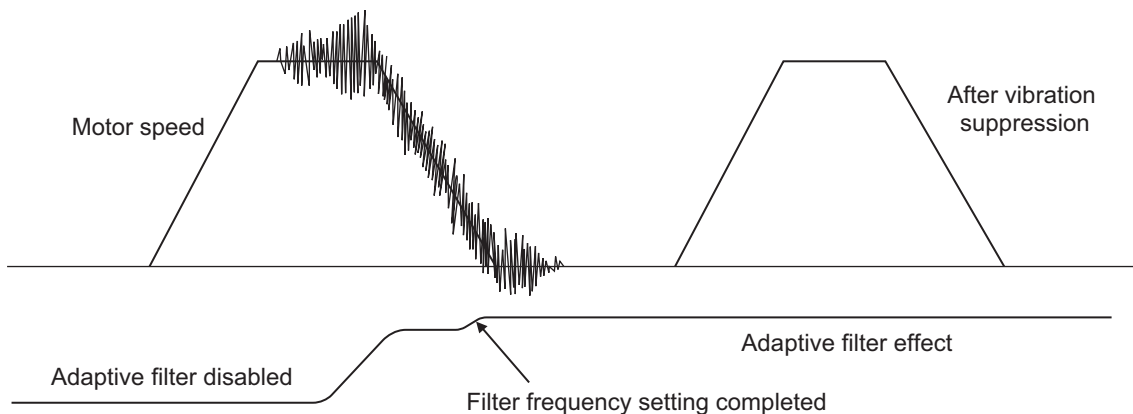

6-2-2 Parameters Requiring Settings

Parameter No.	Name	Description	Reference
Pn200	Adaptive Filter Selection	<p>Set the number of resonance frequencies to be estimated by the adaptive filter and the operation to be performed after estimation.</p> <p>0: Adaptive filter disabled 1: One adaptive filter enabled 2: Two adaptive filters enabled 3: Resonance frequency measurement mode</p> <p>When the influence of a resonance point appears in the motor speed, parameters related to notch filter 3 and 4 are set automatically according to the number of adaptive filters.</p> <p>4: Adaptive result cleared</p> <p>Parameters related to notch filter 3 and 4 are disabled and the adaptive result is cleared.</p>	P.7-20



Precautions for Correct Use

- Adaptive filter may not operate correctly under the following conditions.

Item	Conditions that interfere with the adaptive filter
Resonance points	<ul style="list-style-type: none"> If the resonance frequency is 300 Hz or lower If the resonance peak or control gain is too low to affect the motor speed If there are three or more resonance points
Load	<ul style="list-style-type: none"> If the motor speed with high-frequency components changes due to backlash or other non-linear elements
Command pattern	<ul style="list-style-type: none"> If the acceleration/deceleration is 3,000 r/min/s or higher

- If the adaptive filter does not operate properly, use Notch 1 (Pn201 to Pn203) or Notch 2 (Pn204 to Pn206) parameters to implement resonance measures according to the manual adjustment procedure.
Refer to *6-3 Notch Filters* on page 6-8 for details about the notch filter.
- An unusual noise or vibration may occur until the adaptive filter stabilizes after startup, immediately after the first servo ON, or when the value set in Realtime Autotuning Machine Rigidity Setting (Pn003) is increased. This is not a problem if it disappears right away. If the vibration or unusual noise, however, continues for three or more reciprocating operations, take the following measures in the possible order.
 - Write the parameters used during normal operation to the EEPROM.
 - Lower the value set in Realtime Autotuning Machine Rigidity Setting (Pn003).
 - Disable the adaptive filter by setting Adaptive Filter Selection (Pn200) to 0. (Resetting of inertial estimation and adaptive operation)
 - Manually set the notch filter.
- If unusual noise or vibration occurs, the setting of Notch 3 (Pn207 to Pn209) or Notch 4 (Pn210 to Pn212) may have changed to an extreme value. In this case, set Adaptive Filter Selection (Pn200) to 0 to disable the parameter and then set Notch 3 Frequency Setting (Pn207) and Notch 4 Frequency Setting (Pn210) to 5,000 (disabled). Next, enable Adaptive Filter Selection again.
- Notch 3 Frequency Setting (Pn207) and Notch 4 Frequency Setting (Pn210) are written to the EEPROM every 30 minutes. When the power supply is turned OFF and then turned ON again, this data is used as the default settings to perform adaptive operation.

6-3 Notch Filters

6-3-1 Outline of the Function

Four notch filters can be set for the torque command.

If a ball screw or other controlled device causes resonance at a specific location, you can set the resonance frequency using a notch filter to eliminate resonance.

A notch filter is used to eliminate a specified frequency component.

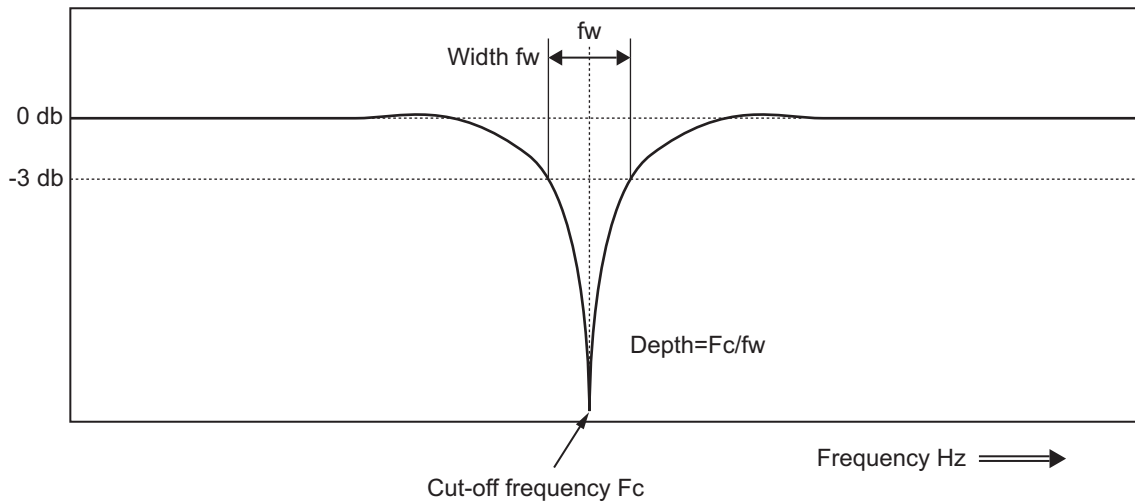

If mechanical resonance occurs, use this notch filter to eliminate resonance.

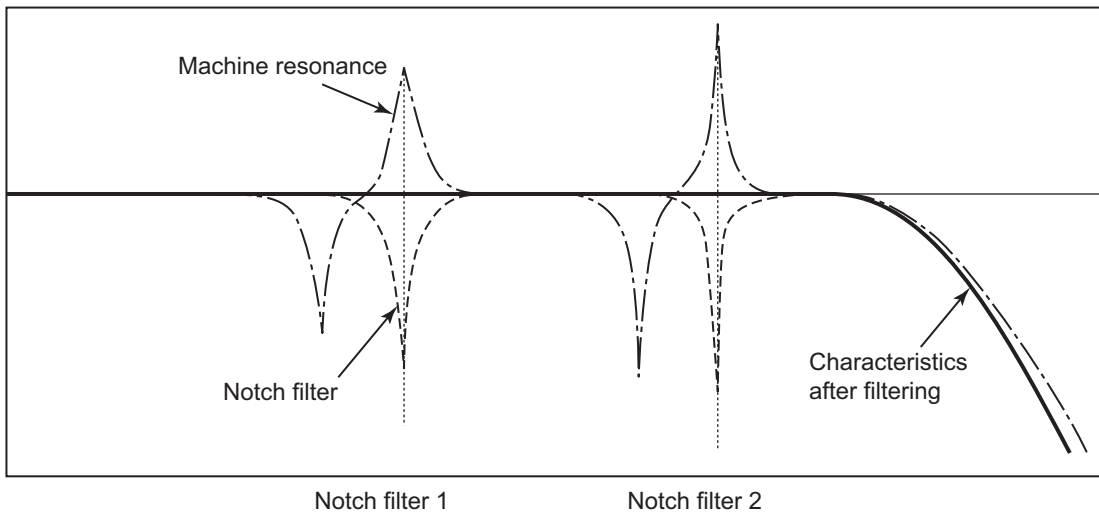

6-3-2 Parameters Requiring Settings

Parameter No.	Name	Description	Reference
Pn201	Notch 1 Frequency Setting	Set the center frequency of notch filter 1. The notch filter is enabled at 50 to 4,999 Hz, and disabled at 5,000 Hz.	P.7-20
Pn202	Notch 1 Width Setting	Select the width of the notch filter 1 frequency. Increasing the value widens the notch width. (Setting range: 0 to 20)	P.7-20
Pn203	Notch 1 Depth Setting	Select the depth of the notch filter 1 center frequency. Increasing the value decreases the notch depth and thereby reduces the phase delay. The notch filter is disabled if 100 is set. (Setting range: 0 to 99)	P.7-20
Pn204	Notch 2 Frequency Setting	Set the center frequency of notch filter 2. Details are the same as those of Notch 1 Frequency Setting.	P.7-20
Pn205	Notch 2 Width Setting	Select the width of the notch filter 2 frequency. Details are the same as those of Notch 1 Width Setting.	P.7-21
Pn206	Notch 2 Depth Setting	Select the depth of the notch filter 2 center frequency. Details are the same as those of Notch 1 Depth Setting.	P.7-21
Pn207	Notch 3 Frequency Setting ^{*1}	Set the center frequency of notch filter 3. Details are the same as those of Notch 1 Frequency Setting.	P.7-21
Pn208	Notch 3 Width Setting ^{*1}	Select the width of the notch filter 3 frequency. Details are the same as those of Notch 1 Width Setting.	P.7-21
Pn209	Notch 3 Depth Setting ^{*1}	Select the depth of the notch filter 3 center frequency. Details are the same as those of Notch 1 Depth Setting.	P.7-21
Pn210	Notch 4 Frequency Setting ^{*1}	Set the center frequency of notch filter 4. Details are the same as those of Notch 1 Frequency Setting.	P.7-21
Pn211	Notch 4 Width Setting ^{*1}	Select the width of the notch filter 4 frequency. Details are the same as those of Notch 1 Width Setting.	P.7-21
Pn212	Notch 4 Depth Setting ^{*1}	Select the depth of the notch filter 4 center frequency. Details are the same as those of Notch 1 Depth Setting.	P.7-21

*1 If an adaptive filter is used, these parameters are set automatically.



Precautions for Correct Use

- Identify the resonance frequency using the frequency characteristics measurement function, resonance frequency monitor, or operation waveform of the waveform graphics function of CX-Drive and set the identified frequency as the notch filter frequency.

Notch Filter Width and Depth

● Width Setting

This is the ratio of the frequency bandwidth at a damping factor of -3 [dB] relative to the center frequency when the depth is 0. This value should conform to the left column in the table below.

● Depth Setting

This is the I/O ratio at which the center frequency input is completely cut off at a set value of 0 and completely passed at a set value of 100. If the indication unit is [dB], this value should conform to the right column in the table below.

Width	
Set value	Bandwidth/ center frequency
0	0.50
1	0.59
2	0.71
3	0.84
4	1.00
5	1.19
6	1.41
7	1.68
8	2.00
9	2.38
10	2.83
11	3.36
12	4.00
13	4.76
14	5.66
15	6.73
16	8.00
17	9.51
18	11.31
19	13.45
20	16.00

Depth		
Set value	I/O ratio [%]	Damping factor [dB]
0	0 (Cut off)	$-\infty$
1	1	-40.0
2	2	-34.0
3	3	-30.5
4	4	-28.0
5	5	-26.0
10	10	-20.0
15	15	-16.5
20	20	-14.0
25	25	-12.0
30	30	-10.5
35	35	-9.1
40	40	-8.0
45	45	-6.9
50	50	-6.0
60	60	-4.4
70	70	-3.1
80	80	-1.9
90	90	-0.9
100	100 (Passed)	0.0

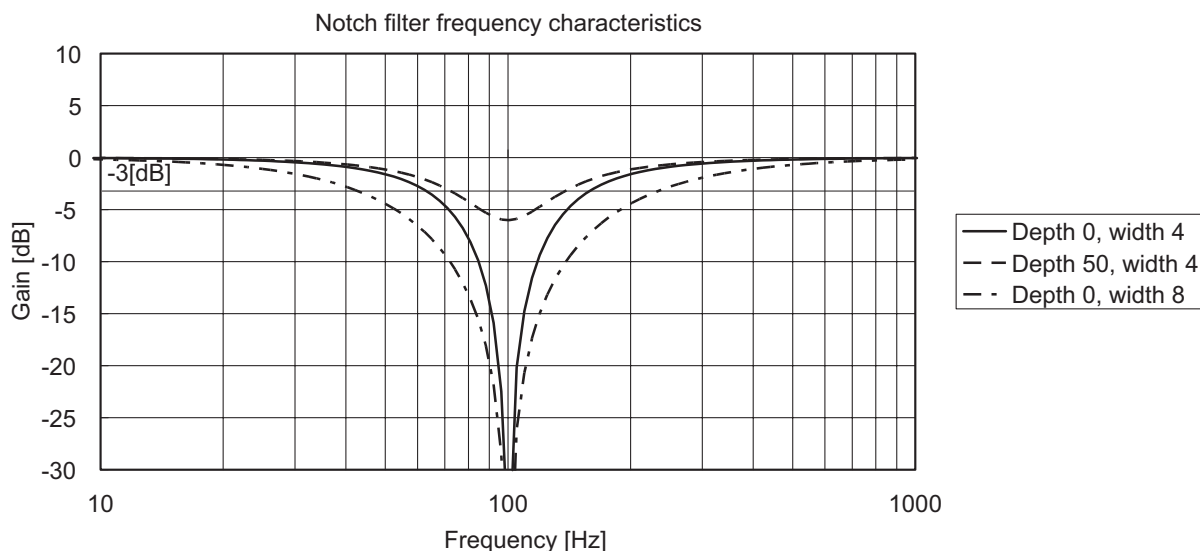

6-4 Electronic Gear Function

6-4-1 Outline of the Function

- The electronic gear function enables the Servomotor to rotate at the number of pulses calculated by multiplying the position command value by the electronic gear ratio.
- This function is enabled in position control mode.

6-4-2 Parameters Requiring Settings

Parameter No.	Name	Description	Reference
Pn008	Electronic Gear Integer Setting	Set the number of command pulses corresponding to 1 motor rotation.	P.7-7
Pn009	Electronic Gear Ratio Numerator 1	Set the numerator of the electronic gear ratio. If the set value is 0, the encoder resolution is automatically set as the numerator. • 1,048,576 for a 20-bit incremental encoder	
Pn010	Electronic Gear Ratio Denominator	Set the denominator of the electronic gear ratio.	
Pn500	Electronic Gear Ratio Numerator 2 ^{*1}	Set the numerator of the electronic gear ratio 2.	P.7-42
Pn501	Electronic Gear Ratio Numerator 3 ^{*1}	Set the numerator of the electronic gear ratio 3.	
Pn502	Electronic Gear Ratio Numerator 4 ^{*1}	Set the numerator of the electronic gear ratio 4.	

*1 Switching among Electronic Gear Ratio Numerator 2 to 4 (Pn500 to Pn502) is performed using the electronic gear switching input (GESEL1/GESEL2). The settings of GESEL1 and GESEL2 are as follows

GESEL1	GESEL2	Applicable parameter
OFF	OFF	Electronic Gear Ratio Numerator 1 (Pn009)
ON	OFF	Electronic Gear Ratio Numerator 2 (Pn500)
OFF	ON	Electronic Gear Ratio Numerator 3 (Pn501)
ON	ON	Electronic Gear Ratio Numerator 4 (Pn502)

Any values can be set in PN008, Pn009, and Pn010, however if an extreme electronic gear ratio is set, the operation is not guaranteed. Set the electronic gear ratio to between 1/1,000 and 1,000.

Gear Ratio Setting (Pn008, Pn009, and Pn010)

Electronic Gear Integer Setting (Pn008)	Electronic Gear Ratio Numerator 1 (Pn009)	Electronic Gear Ratio Denominator (Pn010)	Description
1 to 1,058,576	–	–	<p>When Electronic Gear Integer Setting (Pn008) is not 0, the processing is performed based on the values set in Electronic Gear Integer Setting (Pn008), regardless of the values set in Electronic Gear Ratio Numerator 1 (Pn009) and Electronic Gear Ratio Denominator (Pn010).</p> <p>Command pulse input \longrightarrow $\frac{\text{Encoder resolution}}{\text{Electronic Gear Integer Setting (Pn008)}}$ \longrightarrow Position command</p> <p>Position command pulses = Encoder resolution/Electronic Gear Integer Setting (Pn008)</p> <p>When Electronic Gear Integer Setting (Pn008) is not 0, switching among Electronic Gear Ratio Numerator 1 to 4 is disabled.</p>
0	0	1 to 1,073,741,824	<p>When Electronic Gear Integer Setting (Pn008) and Electronic Gear Ratio Numerator 1 (Pn009) are 0, the processing is performed based on the value set in Electronic Gear Ratio Denominator (Pn010).</p> <p>Command pulse input \longrightarrow $\frac{\text{Encoder resolution}}{\text{Electronic Gear Ratio Denominator (Pn010)}}$ \longrightarrow Position command</p> <p>Position command pulses = Encoder resolution/Electronic Gear Ratio Denominator (Pn010)</p>
	1 to 1,073,741,824		<p>When Electronic Gear Integer Setting (Pn008) is 0 and Electronic Gear Ratio Numerator 1 (Pn009) is not 0, the processing is performed based on the values set in Electronic Gear Ratio Numerator 1 (Pn009) and Electronic Gear Ratio Denominator (Pn010).</p> <p>Command pulse input \longrightarrow $\frac{\text{Electronic Gear Ratio Numerator 1 (Pn009)}}{\text{Electronic Gear Ratio Denominator (Pn010)}}$ \longrightarrow Position command</p> <p>Position command pulses = Electronic Gear Ratio Numerator 1 (Pn009)/Electronic Gear Ratio Denominator (Pn010)</p>

6-4-3 Operation Example

- Example of a motor with a 20-bit encoder (1,048,576 pulses/rotation).

When Electronic Gear Integer Setting (Pn008) is not 0

- If Pn008 is set to 2,000, the operation is the same as that of the 2,000 (pulses/rotation) Servomotor.

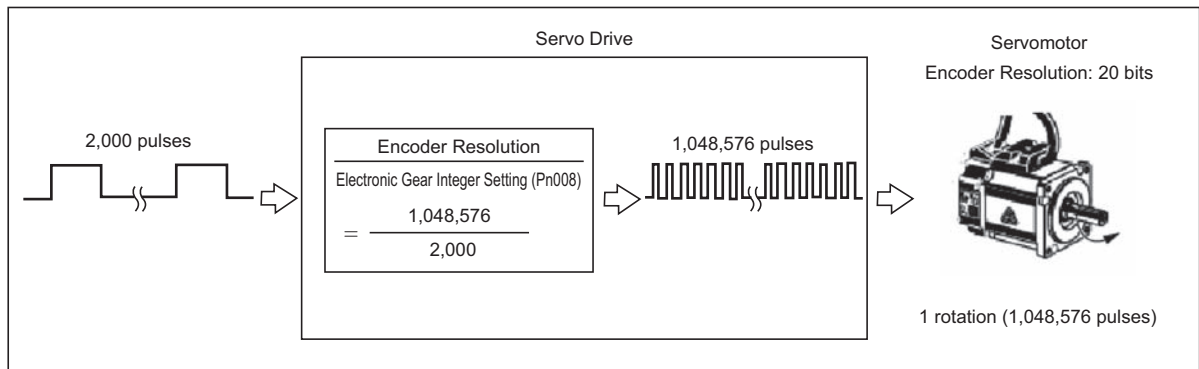

When Electronic Gear Integer Setting (Pn008) and Electronic Gear Ratio Numerator are 0

- If Pn010 is set to 2,000, the operation is the same as that of the 2,000 (pulses/rotation) Servomotor.

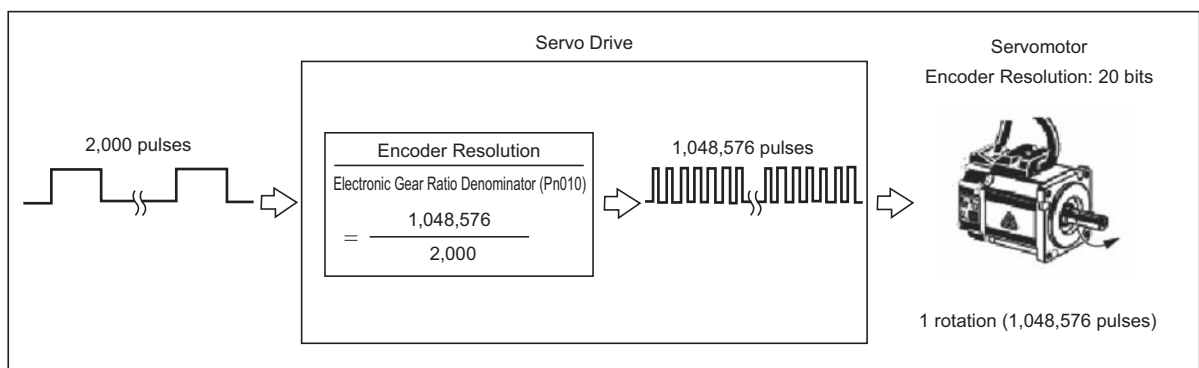

When Electronic Gear Integer Setting (Pn008) is 0 and Electronic Gear Ratio Numerator is not 0

- If Pn009/Pn010 is set to 512/1, the operation is the same as that of the 2,048 (pulses/rotation) Servomotor.

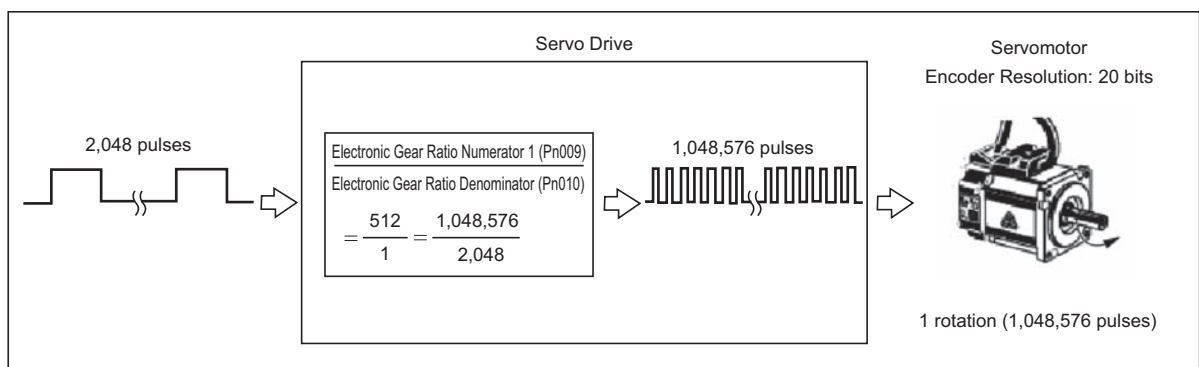



Precautions for Correct Use

- Set the parameters so that the result calculated by multiplying the command pulse by the electronic gear ratio does not exceed 175 Mpps^{*1}.

If it exceeds 175 Mpps^{*1}, Alarm No. 27.2 will occur.

Example:

When using an incremental encoder (resolution: 1,048,576):

If the electronic gear ratio is 500 (Pn008 = 500) and the command pulse value is 100 kpps,

$$100 \text{ kpps} \times 1,048,576/500 = 209,715,200 = 209.7152 \text{ Mpps.}$$

This exceeds 175 Mpps^{*1}.

If the electronic gear ratio is 5,000 (Pn008 = 5,000) and the command pulse value is 100 kpps,

$$100 \text{ kpps} \times 1,048,576/5,000 = 20,971,520 = 20.97152 \text{ Mpps.}$$

This does not exceed 175 Mpps^{*1}.

*1 Alarm No. 27.2 will occur if 3 Gpps is exceeded when using software version 1.10 or higher. The software version can be checked on the front panel or with the CX-Drive. For information on checking the software version on the front panel, refer to *8-4 Mode Setting* on page 8-6.

6-5 Encoder Dividing Function

6-5-1 Outline of the Function

- The encoder dividing function enables you to adjust the number of output pulses from the Servo Drive.
- The number of output pulses per motor rotation can be set in the range of 1 to the number of encoder resolution pulses.
- This function is useful in the following cases:
 - When you use a controller with a low response frequency
 - When you want to set the pulse rate as a simple value

Example: If the encoder resolution is 5 $\mu\text{m}/\text{pulse}$ in a mechanical system that generates a movement of 10 mm per motor rotation, set the encoder dividing ratio to 2,000 (pulses/rotation).

6-5-2 Parameters Requiring Settings

Parameter No.	Name	Description	Reference
Pn011	Encoder Dividing Numerator	Set the number of output pulses per motor rotation for phase A and B respectively.	P.7-8
Pn012	Encoder Output Direction Switching Selection	Select the phase-B logic and the output source for pulse regeneration output.	P.7-8
Pn503	Encoder Dividing Denominator	Set the denominator if the number of pulses per motor rotation in pulse regeneration is not an integer.	P.7-42
Pn533	Pulse Regeneration Output Limit Setting	Set whether to enable or disable the detection of Alarm No. 28.0 "Pulse regeneration error". 0: Disabled 1: Enabled	P.7-54

Encoder Dividing Ratio Setting (Pn011 and Pn503)

Encoder Dividing Numerator (Pn011)	Encoder Dividing Denominator (Pn503)	Description
1 to 262,144	0	<p>[Output source: Encoder]</p> <p>When Encoder Dividing Denominator (Pn503) is 0: The number of output pulses is calculated based on Encoder Dividing Numerator (Pn011) as follows.</p> <div style="text-align: center;"> </div> <p>Number of output pulses per rotation = Encoder Dividing Numerator (Pn011) x 4</p>
1 to 262,144	1 to 262,144	<p>When Encoder Dividing Denominator (Pn503) is not 0: The number of output pulses is calculated based on Encoder Dividing Numerator (Pn011) and Encoder Dividing Denominator (Pn503) as follows.</p> <div style="text-align: center;"> </div> <p>Number of output pulses per rotation = $\frac{\text{Encoder Dividing Numerator (Pn011)}}{\text{Encoder Dividing Denominator (Pn503)}} \times \text{Encoder resolution}$</p>

For the phase-Z signal, one pulse will be output per motor rotation. When Encoder Dividing Denominator (Pn503) is not 0, the phase-Z signal will not be output in sync with the phase-A signal unless the resolution of pulse output per rotation is a multiple of 4. In this case, the phase-Z signal will be output at the encoder resolution and its width may be narrower.

● Phase-Z Signal Output

When Pn011/Pn503 is an integer

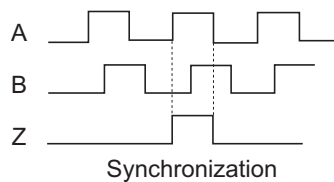

When Pn011/Pn503 is not an integer

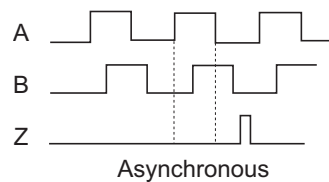

Encoder Output Direction Switching Selection (Pn012)

The scale corresponding to each output type is as follows.

Encoder Output Direction Switching Selection (Pn012)	Output source	Phase-B logic	When operating in forward direction	When operating in reverse direction
0	Encoder	Non-reverse		
2	Reserved (Do not set.)			
1	Encoder	Reverse		
3	Reserved (Do not set.)			

6-6 Brake Interlock

6-6-1 Outline of the Function

- This function enables you to set the output timing for the Brake Interlock Output (BKIR) signal that activates the holding brake when the servo is turned ON, an alarm occurs, or the servo is turned OFF.

6-6-2 Parameters Requiring Settings

Parameter No.	Name	Description	Reference
Pn437	Brake Timing When Stopped	Set the time after a servo OFF command is issued upon servo lock stop, until the Brake Interlock Output (BKIR) signal turns OFF and power supply stops.	P.7-39
Pn438	Brake Timing During Operation	Set the time after a servo OFF command is issued while the motor rotates, until the Brake Interlock Output (BKIR) signal turns OFF and power supply stops. If the speed drops to the setting speed or lower in Pn439 before the time set here elapses, BKIR will turn OFF.	P.7-40
Pn439	Brake Release Speed Setting During Operation	Set the speed at which to turn OFF power to the Servomotor when the Brake Interlock Output (BKIR) signal turns OFF after execution of a servo OFF command while the Servomotor rotates. If the time set in Pn438 elapses before the speed drops to this threshold value or lower, BKIR will turn OFF.	P.7-41

6-6-3 Precautions for Correct Use of Holding Brake

- The brake built into a Servomotor with a brake is a non-excitation brake designed only to hold the motor in the stop status when the operation is stopped. Accordingly, set an appropriate time so that the brake is activated after the motor stops.
- If the brake is engaged while the Servomotor is rotating, the brake disc will wear abnormally or sustain damage, resulting in a bearing or encoder failure in the Servomotor.

6-6-4 Operation

Servo ON/OFF Operation Timing (When Motor is Stopped)

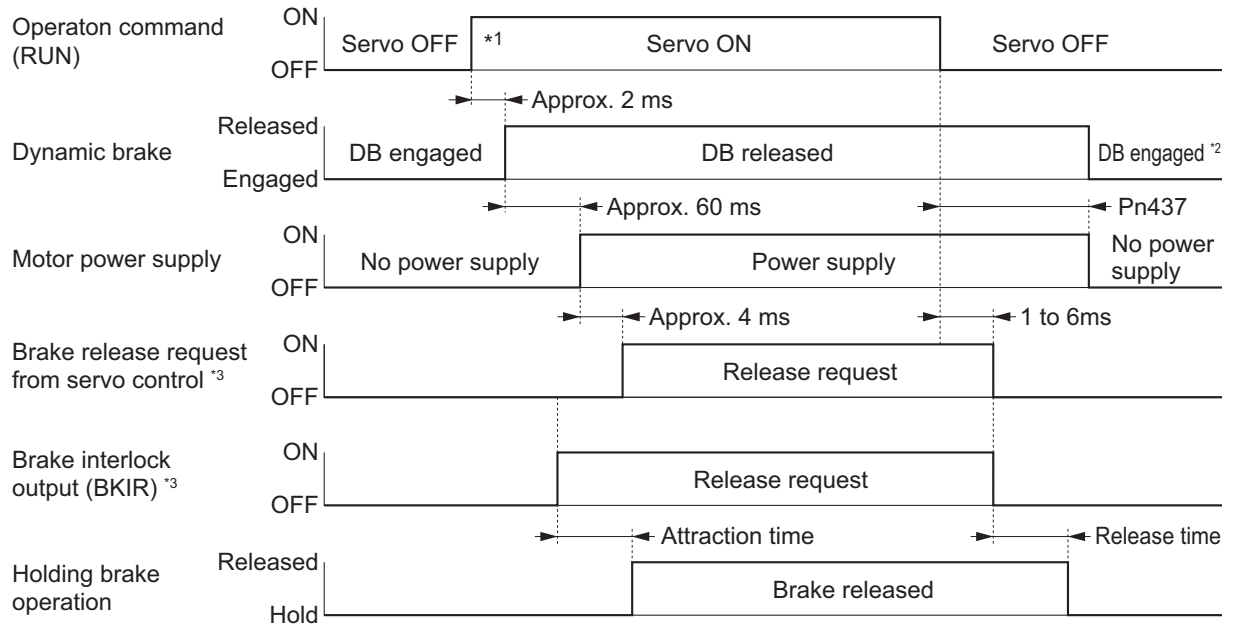

*1 The servo does not turn ON until the motor rotation speed drops to approximately 30 r/min or lower.

*2 The operation of the dynamic brake when the servo is OFF depends on the value set in Stop Selection with Servo OFF (Pn506).

*3 The Brake Interlock Output (BKIR) signal is output when a release request command is received from servo control. The BKIR signal is allocated to the general-purpose output (CN1).

Note The brake attraction time and release time vary depending on the Servomotor brake. Please refer to 3-3 *Servomotor Specifications* on page 3-36 for details.

Servo ON/OFF Operation Timing (When Motor is Rotating)

Based on these operation timings, regenerative energy is produced if the motor rotation stops abnormally.

Accordingly, repeated operation cannot be performed. Provide a wait time of at least 10 minutes for the motor to cool down.

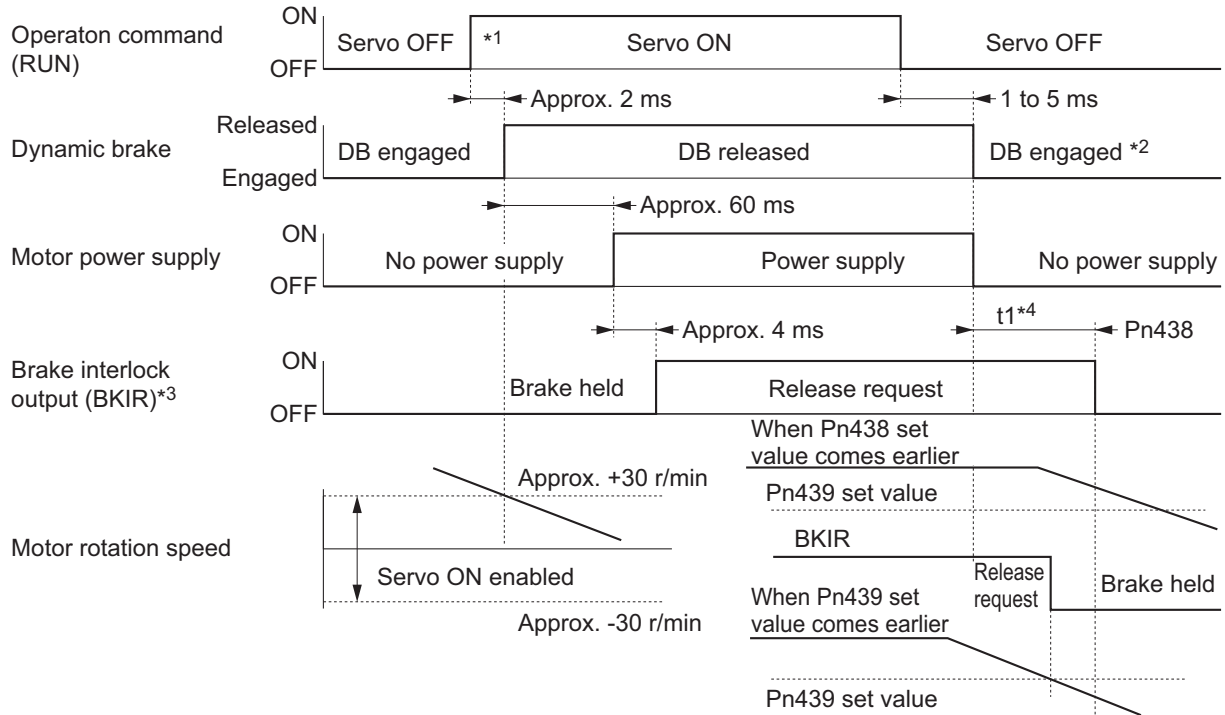

*1 The servo does not turn ON until the motor rotation speed drops to the set value or lower in Pn439.

*2 The operation of the dynamic brake when the servo is OFF depends on the set value in Stop Selection with Servo OFF (Pn506).

*3 The Brake Interlock Output (BKIR) signal is output when a release request command is received from servo control. The BKIR signal is allocated to the general-purpose output (CN1). In the above example, no release request is received from the network.

*4 "t1" is the time set in the Brake Timing During Operation (Pn438), or the time until the motor speed drops to the setting speed or lower in Brake Release Speed Setting (Pn439), whichever is shorter.

Note Even when the Servo ON input is turned ON again while the motor is decelerating, the system does not enter the servo ON state until the motor stops.

Operation Timing When an Alarm Occurs (Servo ON)

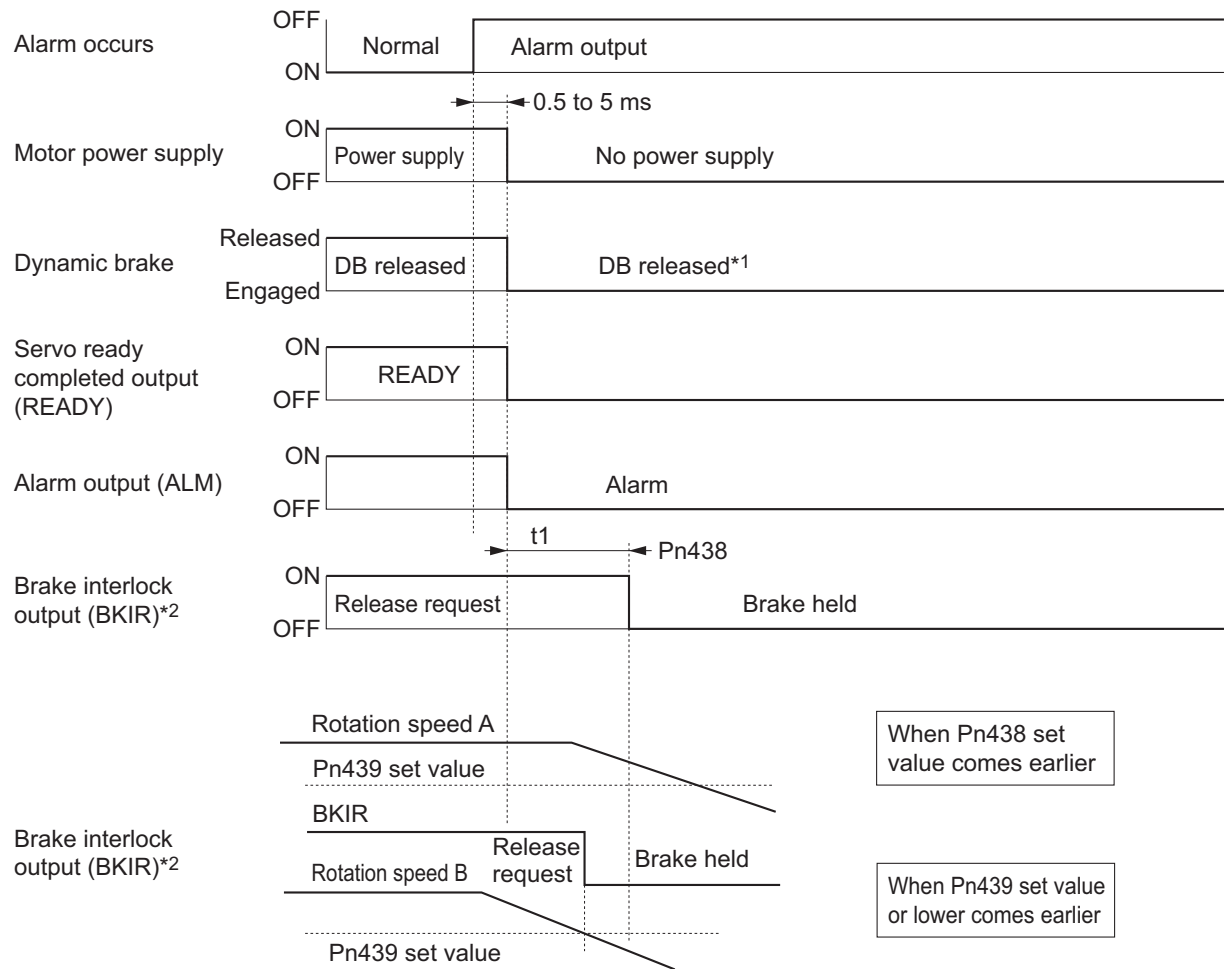

*1 The operation of the dynamic brake when there is an alarm depends on the set value in Stop Selection with Servo OFF (Pn506).

*2 "t1" is the time set in the Brake Timing During Operation (Pn438), or the time until the motor speed drops to the setting speed or lower in Brake Release Speed Setting (Pn439), whichever is shorter.

Note 1 Even when the Servo ON input is turned ON again while the motor is decelerating, the system does not enter the servo ON state until the motor stops. The Brake Interlock Output (BKIR) signal is allocated to the general-purpose output (CN1).

2 If the main circuit power supply turns OFF while the motor is operating, a phase loss alarm or main circuit voltage low alarm will occur, in which case this operation timing is applied.

Operation Timing When an Alarm is Reset

Reset alarms by turning OFF and then ON the power supply.

The alarm reset input recognition time can be changed in Alarm Reset Condition Setting (Pn516). The default setting is 120 ms.

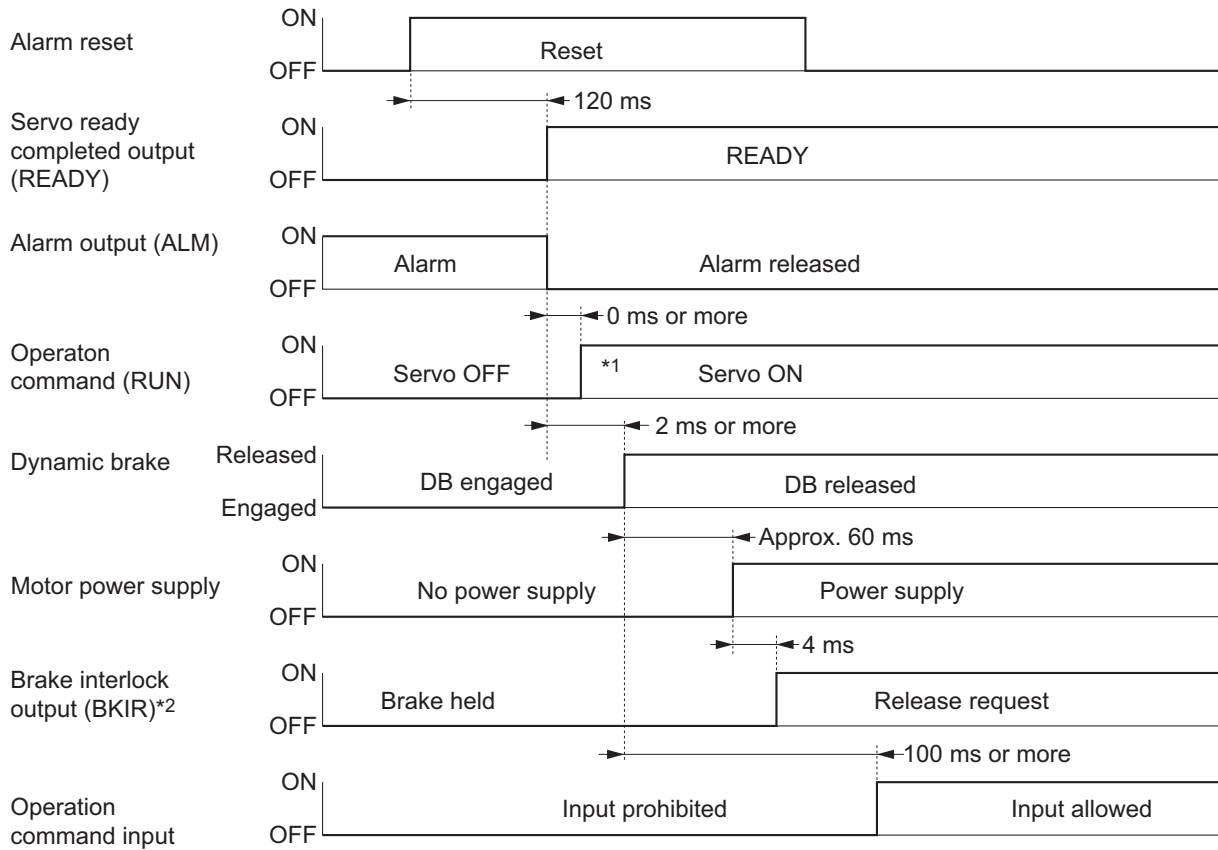

*1 The servo does not turn ON until the motor rotation speed drops to approximately 30 r/min or lower.

*2 The Brake Interlock Output (BKIR) signal is output when a release request command is received from servo control. The BKIR signal is allocated to the general-purpose output (CN1).

Note After an alarm is reset, the system enters the servo OFF state (motor not energized). To turn ON the servo, after resetting the alarm, send the servo ON command again according to the above timing.

6-7 Gain Switching Function

6-7-1 Outline of the Function

- The gain switching function switches the position and speed loop gain.
- Select “enable” or “disable” in Gain Switching Input Operating Mode Selection (Pn114). Set the switching condition using the gain switching setting.
- If the load inertia changes or you want to change the responsiveness depending on whether the motor is stopping or operating, you can perform optimal control by using gain switching.
- The gain switching function is used when realtime autotuning does not work effectively, such as:
 - When the load inertia fluctuates at 200 ms or less
 - When the motor rotation speed does not exceed 500 r/min, or the load torque does not exceed 50% of the rated torque
 - When an external force is constantly applied, as with a vertical axis

Note While Gain 2 is selected, realtime autotuning does not operate normally. To use the gain switching function, set Realtime Autotuning Mode Selection to “disabled” (Pn002 = 0).

6-7-2 Parameters Requiring Settings

Parameter No.	Name	Description	Reference
Pn114	Gain Switching Input Operating Mode Selection	Set to enable or disable the gain switching function.	P.7-13
Position control mode			
Pn115	Switching Mode in Position Control	Set the condition for switching between Gain 1 and Gain 2.	P.7-14
Pn116	Gain Switching Delay Time in Position Control	Set the time to return from Gain 2 to Gain 1. (Unit: 0.1 ms)	P.7-15
Pn117	Gain Switching Level in Position Control	Set the judgment level for switching between Gain 1 and Gain 2.	P.7-16
Pn118	Gain Switching Hysteresis in Position Control	Set the hysteresis width to be used for the judgment level set in Gain Switching Level (Pn117).	P.7-16
Pn119	Position Gain Switching Time	Set the time to change gradually from low to high gain. (Unit: 0.1 ms)	P.7-16

Timing of Gain Switching by Gain Switch Setting

Switching between the Gain 1 (Pn100 to Pn104) and Gain 2 (Pn105 to Pn109) occurs at the following timing. For the position loop gain, switching occurs based on the value set in Pn119.

For information of each gain, refer to *Section 7 Parameter Details*.

The details of the gain switch settings vary depending on the control mode to be used. For details about the settings available in each mode, refer to *Gain Switching Setting for Each Control Mode* on page 6-30.

● Gain Switching Mode = 2: Gain Switching (GSEL)

Instant switching occurs when a gain switching command is issued from the network.

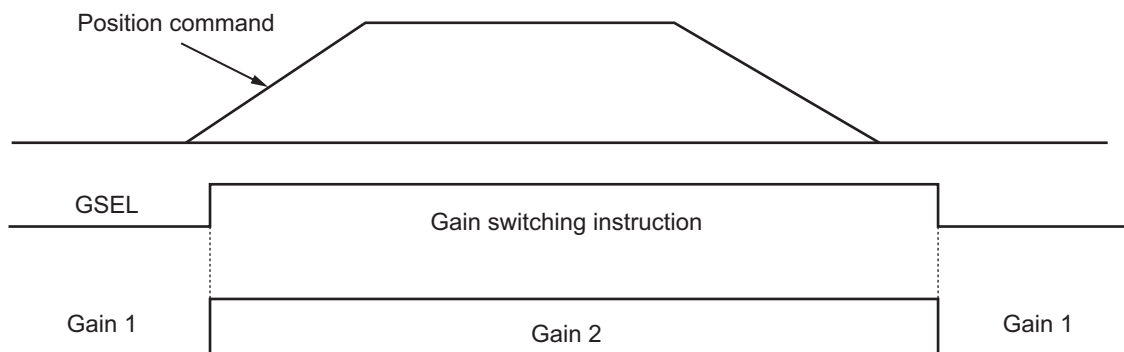

● **Gain Switching Mode = 3: Switching by Amount of Change in Torque Command**

Set the amount of change in torque command (angular acceleration and deceleration command) in units of 0.05%/166 μ s.

If the amount of change fluctuates and the switching time is not met, switching is cancelled.

To switch when the amount of change reaches 4% in 2 ms (0.33%/166 μ s), set the value to approximately 6.

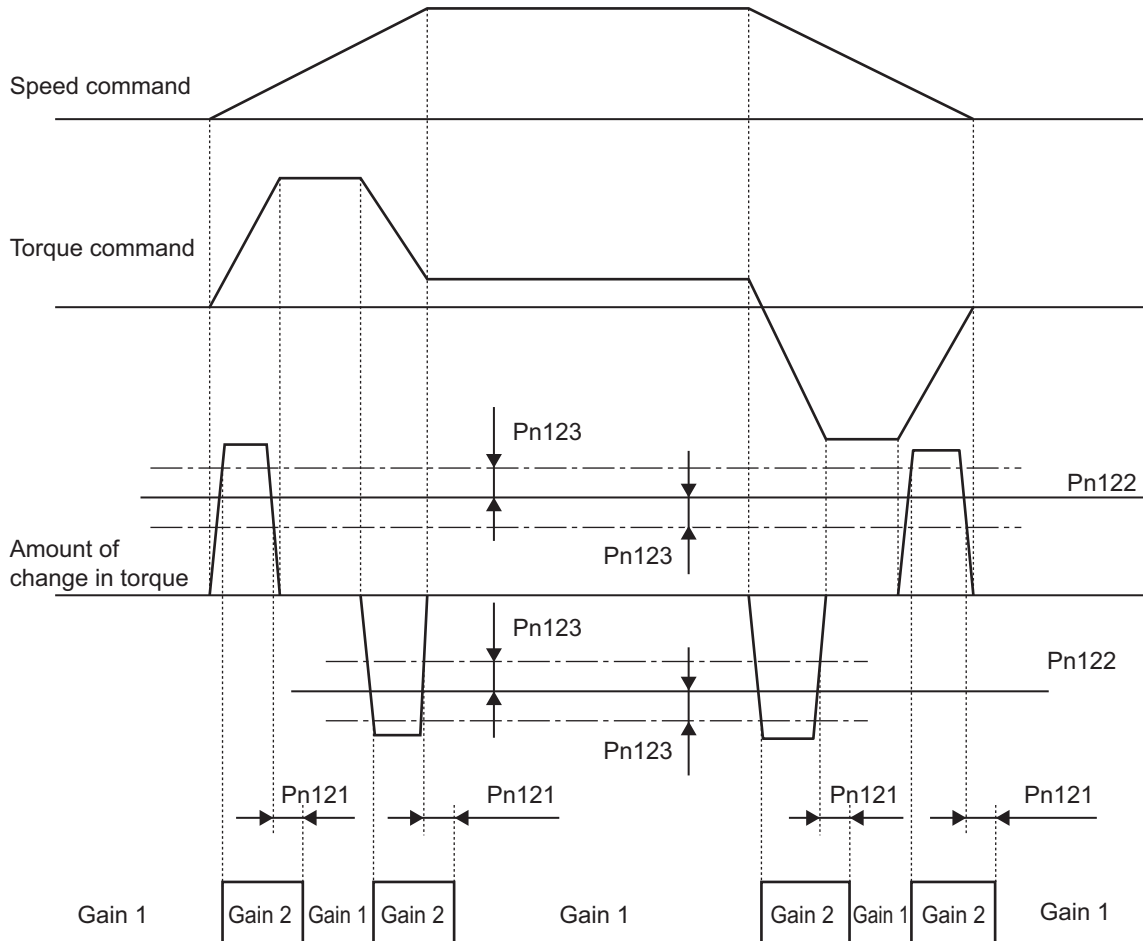

● **Gain Switching Mode = 5 or 9: Switching by Speed Command or Actual Motor Speed**

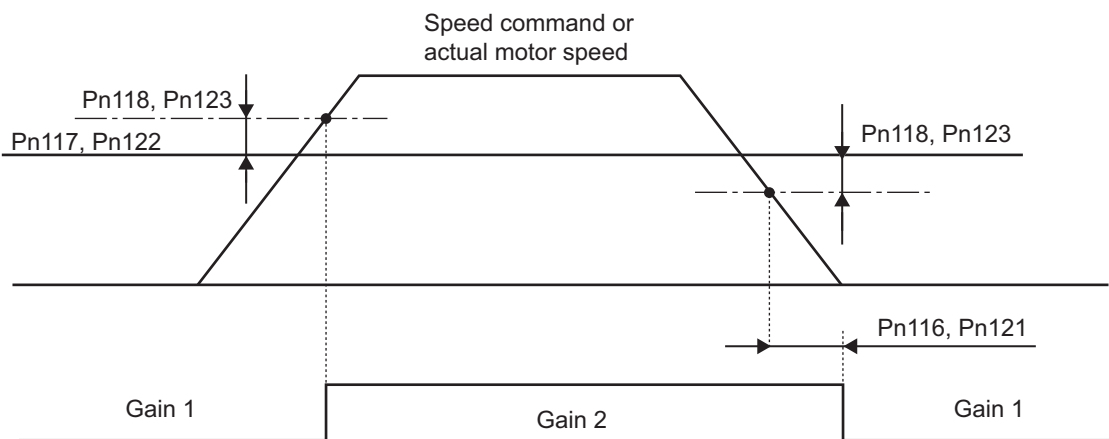

- **Gain Switching Mode (Pn031) = 6: Switching by Amount of Position Error**

Gain switching is performed based on the accumulated pulse in the error counter.

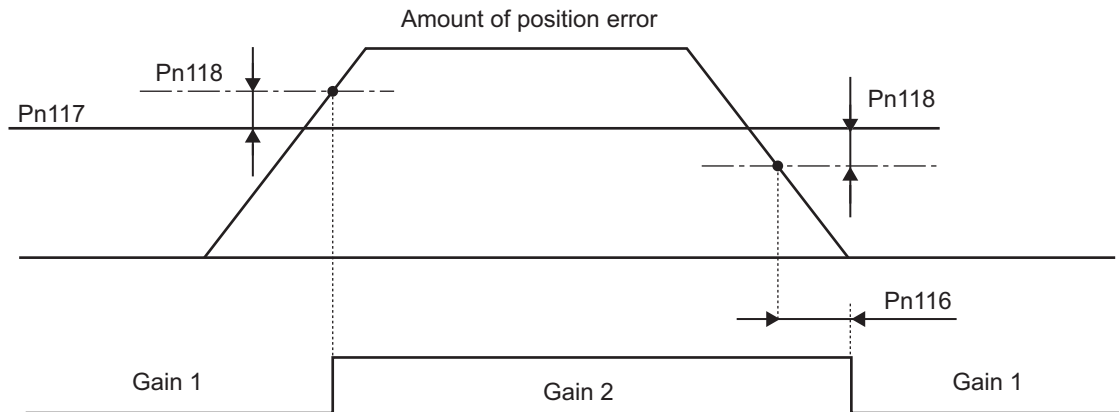

- **Gain Switching Mode = 7: Switching by Position Command Input**

Gain switching is performed when a position command corresponding to 1 command unit or more is input.



● **Gain Switching Mode = 8: Switching by Positioning Completion Signal OFF**

Switching to the Gain 2 is performed when the accumulated pulse in the error counter exceeds Positioning Completion Range 1 (Pn431).

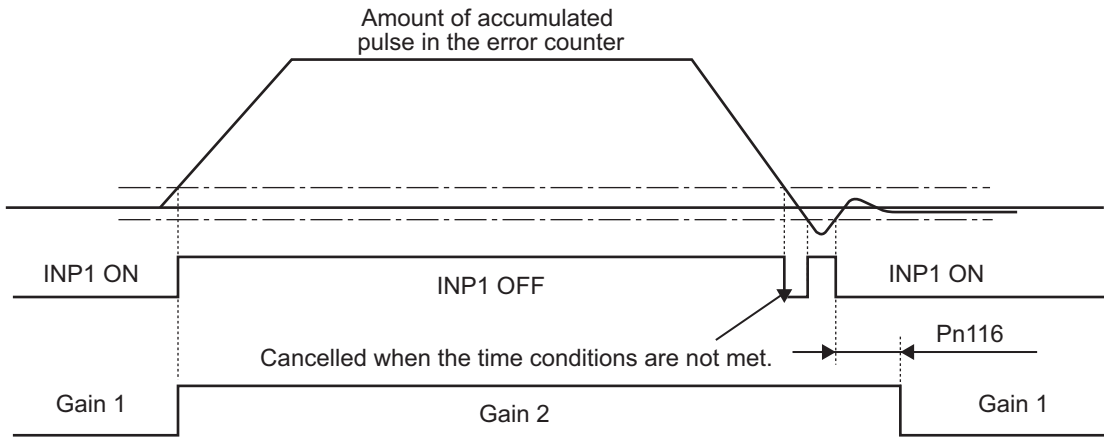

● **Gain Switching Mode = 10: Switching by Combination of Position Command Input and Speed**

Switching to Gain 2 occurs when the position command is input.

Switching to Gain 1 occurs if no position command is issued for the period of Gain Switching Delay Time in Speed Control (Pn121) and the speed also becomes the same as or less than the result of Gain Switching Level (Pn122) minus Gain Switching Hysteresis (Pn123) [r/min].

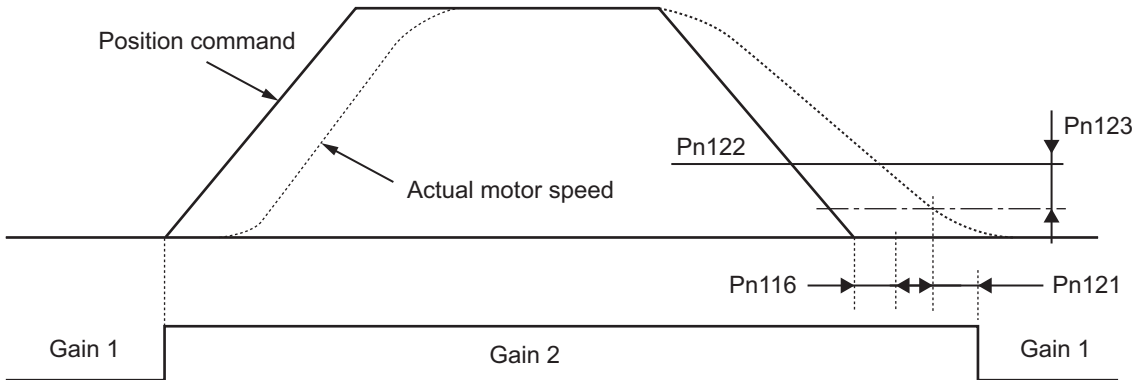

Timing of Gain Switching by Position Gain Switching Time (Pn119)

When using the position control, setting Gain Switching Time helps prevent the rapid increase of the position loop gain if the values set in Position Loop Gain (Pn100) and Position Loop Gain 2 (Pn105) differ significantly.

The position loop gain increases as the set time expires.

Position Gain Switching Time

The Position Gain Switching Time (Pn119) can be set to reduce torque fluctuations and vibration caused by a sudden change in the position loop gain when the gain is switched during position control.



Precautions for Correct Use

When the position loop gain is switched to a smaller value, switching of the gain occurs immediately regardless of this parameter setting.

Example: Gain 1 (Pn100) > Gain 2 (Pn105)

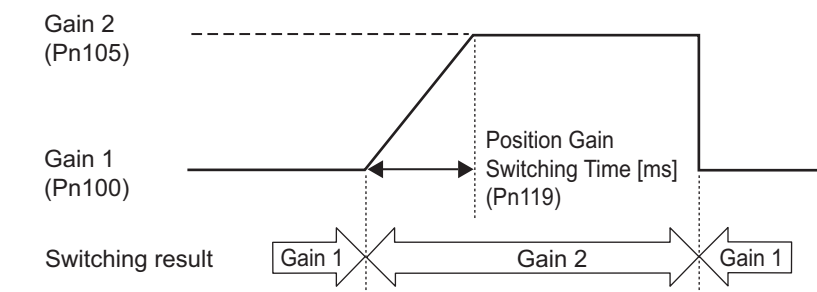

Gain Switching Setting for Each Control Mode

The available gain switching condition settings vary depending on the control mode to be used. Set parameters for each control mode.

● Position Control Mode

In the position control mode, the available settings depend on the value set in Switching Mode in Position Control (Pn115).

(√: Enabled, –: Disabled)

Pn115 set value	Switching condition	Gain Switching Delay Time (Pn116)	Gain Switching Level (Pn117)	Gain Switching Hysteresis (Pn118)	Position Gain Switching Time (Pn119)
0	Always Gain 1	–	–	–	–
1	Always Gain 2	–	–	–	–
2	Switching using gain switching input (GSEL)	–	–	–	√
3	Amount of change in torque command	√	√ [0.05%]	√ [0.05%]	√
4	Always Gain 1	–	–	–	–
5	Command speed	√	√ [r/min]	√ [r/min]	√
6	Amount of position error	√	√ [Pulse]	√ [Pulse]	√
7	Position command input	√	–	–	√
8	Positioning completion output (INP1) OFF	√	–	–	√
9	Actual motor speed	√	√ [r/min]	√ [r/min]	√
10	Combination of position command input and speed	√	√	√	√

● Speed Control Mode

In the speed control mode, the available settings depend on the value set in Switching Mode in Speed Control (Pn120).

(√: Enabled, –: Disabled)

Pn120 set value	Switching condition	Gain Switching Delay Time (Pn121)	Gain Switching Level (Pn122)	Gain Switching Hysteresis (Pn123)
0	Always Gain 1	–	–	–
1	Always Gain 2	–	–	–
2	Switching using gain switching input (GSEL)	–	–	–
3	Amount of change in torque command	√	√ [0.05%]	√ [0.05%]
4	Amount of change in speed command	–	–	–
5	Speed command	√	√ [r/min]	√ [r/min]

6-8 Torque Limit

6-8-1 Outline of the Function

- The torque limit function limits the output torque of the Servomotor.
- This function is used in the following conditions.
 - When push-motion operation, such as pressing, is performed.
 - When the torque at startup and during deceleration should be suppressed to protect mechanical systems, etc.
- Various torque limit options can be set in Torque Limit Selection (Pn521).

Parameter No.	Name	Description	Reference
Pn521	Torque Limit Selection	Select the torque limit based on the various parameters and input signals.	P.7-51
Pn013	No. 1 Torque Limit	Set the first motor output torque limit value.	P.7-8
Pn522	No. 2 Torque Limit	Set the second motor output torque limit value.	P.7-51
Pn523	Torque Limit Switching Setting 1	Set the rate of change (fluctuation) when switching from No. 1 Torque Limit to No. 2 Torque Limit.	P.7-52
Pn524	Torque Limit Switching Setting 2	Set the rate of change (fluctuation) when switching from No. 2 Torque Limit to No. 1 Torque Limit.	P.7-52
Pn525	Forward External Torque Limit	Set the forward torque limit based on a network signal.	P.7-52
Pn526	Reverse External Torque Limit	Set the reverse torque limit based on a network signal.	P.7-52

Torque Limit in Position/Speed Control

Pn521 set value	Description
0	Reserved (Do not set.)
1	Limit in both forward and reverse directions: Set in Pn013
2	Forward: Set in Pn013 Reverse: Set in Pn522
3	Switching the limit value by the torque limit switching (TLSEL) When TLSEL is OFF Limit in both forward and reverse directions: Set in Pn013 When TLSEL is ON Limit in both forward and reverse directions: Set in Pn522
4	Reserved (Do not set.)
5	Reserved (Do not set.)
6	Switching the limit value by the torque limit switching (TLSEL) When TLSEL is OFF Forward: Set in Pn013 Reverse: Set in Pn522 When TLSEL is ON Forward: Set in Pn525 Reverse: Set in Pn526

- When torque feed-forward is selected, the torque limit function is enabled only during speed control when the set value is 1 to 3.

Rate of Change Setting at Switching (Pn521 = 3)

When Torque Limit Selection (Pn521) is set to 3, you can set the rate of change with a fluctuation during switching. This function is disabled with other settings.

● How to Set the Rate of Change (Slope)

Set the following parameter according to the switching type.

- Switching from No. 1 Torque Limit to No. 2 Torque Limit: Pn523
- Switching from No. 2 Torque Limit to No. 1 Torque Limit: Pn524

The sign of the rate of change switches automatically inside the Servo Drive based on the magnitude relationship between No. 1 Torque Limit and No. 2 Torque Limit.

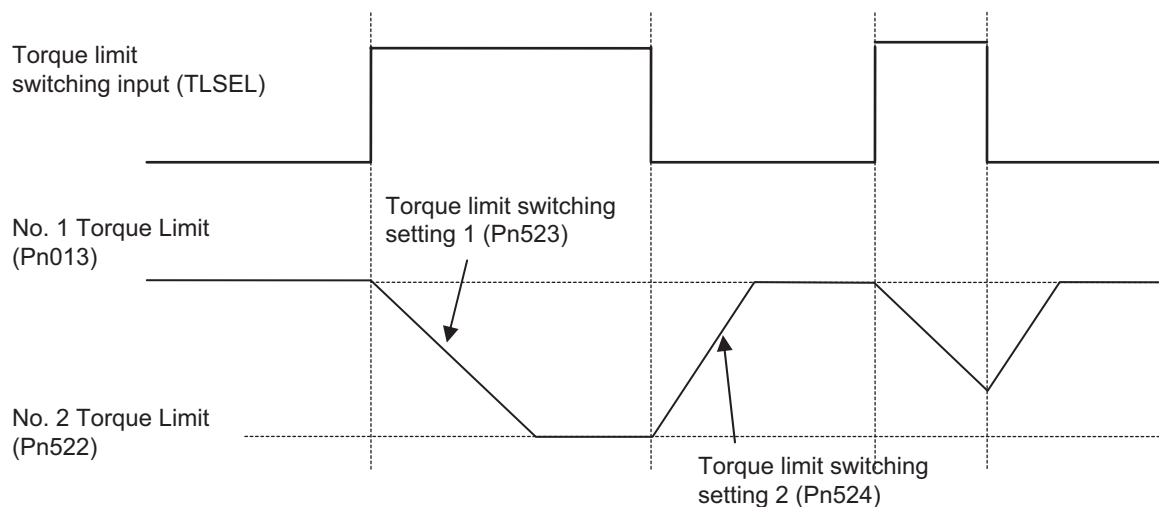

If the No. 1 Torque Limit (Pn013) or No. 2 Torque Limit (Pn522) value is changed from the front panel or CX-Drive, the rate of change setting is ignored and the new torque limit value is applied immediately.

Torque Limit Settings by Servomotors

- The torque limit setting range is between 0% and 300% (default setting: 300%). This is not the case for the following Servo Drive and Servomotor combinations.

Servo Drive	Applicable Servomotor	Maximum torque limit [%]
R88D-KP15H	R88M-KE90010□	225
R88D-KP30H	R88M-KE2K010□	250
R88D-KP50H	R88M-KE3K010□	250
	R88M-KE4K510□	263

6-9 Sequence I/O Signals

6-9-1 Outline of the Function

- You can set sequences in various operating conditions.
- For the connection of I/O signals and processing of external signals, refer to *3-1-4 Control I/O Connector Specifications (CN1)* on page 3-9.

6-9-2 Input Signals

You can allocate any functions to the input pins of the control I/O connector (CN1). In addition, you can change the logic. However, some signals have limitations in the allocation. Refer to *Input Signal Allocation Method* on page 6-34 for details.

If you replace a G-series Servo Drive, use the G5-series Servo Drive with the default settings.

Default Input Signal Settings

The allocations of the default input signals are as follows. Refer to *Input Signal Allocation Method* on page 6-34 when you change the allocation to use.

Parameter	Input signal	Default setting	Default setting state			
			Position control		Speed control	
			Signal	logic	Signal	logic
Pn400	SI1	00828282 hex (8553090)	NOT	NC	NOT	NC
Pn401	SI2	00818181 hex (8487297)	POT	NC	POT	NC
Pn402	SI3	0091910A hex (9539850)	DFSEL1	NO	VZERO	NC
Pn403	SI4	00060606 hex (394758)	GSEL	NO	GSEL	NO
Pn404	SI5	0000100C hex (4108)	GESEL1	NO	VSEL3	NO
Pn405	SI6	00030303 hex (1979379)	RUN	NO	RUN	NO
Pn406	SI7	00000f07 hex (3847)	ECRST	NO	VSEL2	NO
Pn407	SI8	00040404 hex (263172)	RESET	NO	RESET	NO
Pn408	SI9	00050505 hex (328965)	TVSEL	NO	TVSEL	NO
Pn409	SI10	00000E88 hex (3720)	IPG	NC	VSEL1	NO

NO and NC in the Logic column above refer to the following states.

NO: Disabled (OFF) when signal input is open with COM-
Enabled (ON) when signal input is shorted with COM-

NC: Disabled (OFF) when signal input is shorted with COM-
Enabled (ON) when signal input is open with COM-

Parameters That can be Allocated

Use the following parameters when changing the input signal allocations.

For the setting method, refer to *Input Signal Allocation Method* on page 6-34.

Parameter No.	Name	Description	Reference
Pn400	Input Signal Selection 1	Set the SI1 input function allocation. This parameter must be set in hexadecimal notation. (The display on the front panel is indicated as a decimal.)	P.7-32
Pn401	Input Signal Selection 2	Set the SI2 input function allocation.	P.7-32
Pn402	Input Signal Selection 3	Set the SI3 input function allocation.	P.7-32
Pn403	Input Signal Selection 4	Set the SI4 input function allocation.	P.7-32
Pn404	Input Signal Selection 5	Set the SI5 input function allocation.	P.7-32
Pn405	Input Signal Selection 6	Set the SI6 input function allocation.	P.7-32
Pn406	Input Signal Selection 7	Set the SI7 input function allocation.	P.7-32
Pn407	Input Signal Selection 8	Set the SI8 input function allocation.	P.7-32
Pn408	Input Signal Selection 9	Set the SI9 input function allocation.	P.7-32
Pn409	Input Signal Selection 10	Set the SI10 input function allocation.	P.7-32

Input Signal Allocation Method

Input the setting in each control mode to any of the parameters from Pn400 to Pn409 to allocate the signal.

These parameters must be set in hexadecimal notation.

Set the set value of the function for each control mode in “***” below.

Refer to the function number table provided below for the set value of each function. The logic setting is included in the function number.

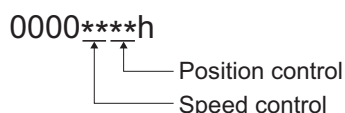
0000****h

For parameters reserved for the system, do not change the values.

Example:

Position control: Electronic Gear Switching input 1 with NO (normally open) contacts (0C hex)

Speed control: Internally Set Speed Selection 1 with NC (normally close) contacts (8E hex)

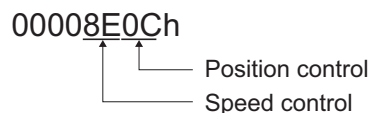
00008E0Ch

The set value on the front panel is indicated as a decimal, which is 36,364 in this case.

● Function Number Table

The set values to be used for allocations are as follows:

Signal	Symbol	Set value	
		NO	NC
Disabled	–	00 hex	Setting not available
Forward Drive Prohibition Input	POT	01 hex	81 hex
Reverse Drive Prohibition Input	NOT	02 hex	82 hex
Operation Command* ¹	RUN	03 hex	83 hex
Alarm Reset Input	RESET	04 hex	Setting not available
Control Mode Switching Input	TVSEL	05 hex	85 hex
Gain Switching	GSEL	06 hex	86 hex
Error Counter Reset Input* ²	ECRST	07 hex	Setting not available
Pulse Prohibition Input* ³	IPG	08 hex	88 hex
Torque Limit Switching	TLSEL	09 hex	89 hex
Damping Filter Switching 1	DFSEL1	0A hex	8A hex
Damping Filter Switching 2	DFSEL2	0B hex	8B hex
Electronic Gear Switching Input 1	GESEL1	0C hex	8C hex
Electronic Gear Switching Input 2	GESEL2	0D hex	8D hex
No. 1 Internally Set Speed	VSEL1	0E hex	8E hex
No. 2 Internally Set Speed	VSEL2	0F hex	8F hex
No. 3 Internally Set Speed	VSEL3	10 hex	90 hex
Zero Speed Designation Input	VZERO	11 hex	91 hex
Speed Command Sign Input	VSIGN	12 hex	92 hex
Emergency Stop Input	STOP	14 hex	94 hex
Inertia Ratio Switching Input	J-SEL	15 hex	95 hex

*1 The Operation Command (RUN) must be allocated. Servo cannot be turned ON if it is not allocated.

*2 Allocate this signal to Input Signal Selection 7 (Pn406). If it is allocated to any other signal, an alarm will occur.

*3 Allocate this signal to Input Signal Selection 10 (Pn409). If it is allocated to any other signal, an alarm will occur.



Precautions for Correct Use

- Do not use any values other than the settings listed.
- If you allocate the same function to more than one input signal, Interface Input Duplicate Allocation Error 1 (Alarm No. 33.0) or Interface Input Duplicate Allocation Error 2 (Alarm No. 33.1) will occur.
- Error Counter Reset Input (ECRST) can be allocated only to Input Signal Selection 7 (Pn406). If it is allocated to other signals, Counter Reset Allocation Error (Alarm No. 33.6) will occur.
- Pulse Prohibition Input (IPG) can be allocated only to Input Signal Selection 10 (Pn409). If it is allocated to signals, Command Pulse Prohibition Input Allocation Error (Alarm No. 33.7) will occur.
- To use Control Mode Switching Input (TVSEL), it must be set for all control modes. Otherwise, Interface Input Function Number Error 1 (Alarm No. 33.2) or Interface Input Function Number Error 2 (Alarm No. 33.3) will occur.
- If Zero Speed Designation Selection (Pn315) is set to 2 or 3, the Zero Speed Designation Input (VZERO) for the position control must be allocated to the same pin as that to which the Zero Speed Designation Input (VZERO) for the speed control is allocated. The logic must also be allocated in the same method.

- The functions that are used by more than one control mode (such as Operation Command and Alarm Reset Input) must be allocated to the same pin with the same logic. If they are not set correctly, Interface Input Duplicate Allocation Error 1 (Alarm No. 33.0) or Interface Input Duplicate Allocation Error 2 (Alarm No. 33.1) will occur.
- The Operation Command (RUN) must be allocated. Servo cannot be turned ON if it is not allocated.

6-9-3 Output Signals

You can allocate any functions to the output pins of the control I/O connector (CN1).

If you replace a G-series Servo Drive, use the G5-series Servo Drive with the default settings.

Default Output Signal Settings

The allocations of the default output signals are as follows. Refer to *Output Signal Allocation Method* on page 6-37 when you change the allocation to use.

Parameter	Output signal	Default setting	Default setting state	
			Position control	Speed control
			Signal	Signal
Pn410	SO1	00030303 hex (197379)	BKIR	BKIR
Pn411	SO2	00020202 hex (131586)	READY	READY
Pn412	SO3	*1	ALM	ALM
Pn413	SO4	00050504 hex (328964)	INP	TGON

*1 Alarm output signal allocation cannot be changed.

Parameters That can be Allocated

Use the following parameters when changing the output signal allocations.

For the setting method, refer to *Output Signal Allocation Method* on page 6-37.

Parameter No.	Name	Description	Reference
Pn410	Output Signal Selection 1	Set the SO1 output function allocation. This parameter must be set in hexadecimal notation. For the setting method, refer to the Function Number Table of output signals.	P.7-32
Pn411	Output Signal Selection 2	Set the SO2 output function allocation.	P.7-33
Pn412	Output Signal Selection 3	Set the SO3 output function allocation. This parameter is fixed to the alarm output signal.	P.7-33
Pn413	Output Signal Selection 4	Set the SO4 output function allocation.	P.7-33

Output Signal Allocation Method

Input the setting in each control mode to any of the parameters from Pn410 to Pn413 to allocate the signal.

The parameters must be set in hexadecimal notation, in the same method as for the input signal allocations.

Set the set value of the function for each control mode in “***” below.

Refer to the function number table provided below for the set value of each function. The logic setting is included in the function number.

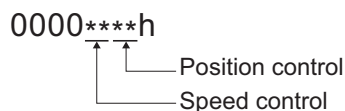
0000***h

For parameters reserved for the system, do not change the values.

Example:

Position control: Speed Conformity Output Signal (08 hex)

Speed control: Motor Rotation Speed Detection Output (05 hex)

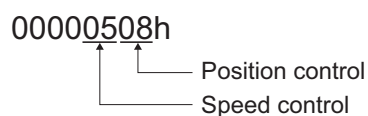
00000508h

The set value on the front panel is indicated as a decimal, which is 1,288 in this case.

● Function Number Table

The set values to be used for allocations are as follows:

Signal	Symbol	Set value
Disabled	—	00 hex
Servo Ready Completed Output	READY	02 hex
Brake Interlock Output	BKIR	03 hex
Positioning Completion Output	INP	04 hex
Motor Rotation Speed Detection Output	TGON	05 hex
Torque Limiting Signal	TLC	06 hex
Zero Speed Detection Signal	ZSP	07 hex
Speed Conformity Output Signal	VCMP	08 hex
Warning Output 1	WARN1	09 hex
Warning Output 2	WARN2	0A hex
Position Command Status Output	P-CMD	0B hex
Positioning Completion Output 2	INP2	0C hex
Alarm Attribute Output	ALM-ATB	0E hex
Speed Command Status Output	V-CMD	0F hex



Precautions for Correct Use

- Do not use any values other than the settings listed.
- You can allocate the same function to more than one output signal.
- For output signals, the logic cannot be changed. The function is disabled (OFF) when signal input is open with COM- and enabled (ON) when signal input is shorted with COM-.

6-10 Forward and Reverse Drive Prohibition Functions

6-10-1 Outline of the Function

- If the Forward Drive Prohibition Input (POT) or Reverse Drive Prohibition Input (NOT) is turned OFF, the motor will stop rotating.
- You can thus prevent the Servomotor from rotating outside of the operating range of the device by using limit inputs from the device connected to the Servo Drive.

6-10-2 Parameters Requiring Settings

Parameter No.	Name	Description	Reference
Pn400 to Pn409	Input Signal Selection 1 to 10	Set the input signal allocations and logic. These parameters are allocated by default as follows. Pn400 (CN1 pin 8): NOT (Logic contact NC) Pn401 (CN1 pin 9): POT (Logic contact NC)	P.7-32
Pn504	Drive Prohibition Input Selection	Set the operation to be performed when the Forward and Reverse Drive Prohibition Input signal turns ON.	P.7-43
Pn505	Stop Selection for Drive Prohibition Input	Set the deceleration and stop methods used when the Forward and Reverse Drive Prohibition Input signal turns ON.	P.7-43

Input Signal Selection Function (Default Settings: Pn400, Pn401)

These parameters are allocated by default as follows.

Parameter No.	Name	Default setting		
		Set value	Position control	Speed control
Pn400	Input Signal Selection 1	00828282	NOT (NC)	NOT (NC)
Pn401	Input Signal Selection 2	00818181	POT (NC)	POT (NC)

- Refer to *6-9 Sequence I/O Signals* on page 6-33 for details about Input Signal Selection 1 to 10.

Drive Prohibition Input Selection (Pn504)

Install limit switches at both ends of the axis to prohibit the Servomotor from driving in the direction specified by the switch. This can be used to prevent the workpiece from driving too far and thus prevent damage to the machine. Set the operation to be performed upon forward and reverse drive prohibition input.

Drive Prohibition Input Selection (Pn504)	Description
0	<p>Forward and Reverse Drive Prohibition Input function enabled</p> <p>The function operates as follows when a signal is input:</p> <p>When Forward Drive Prohibition Input is shorted: Normal state in which the forward limit switch does not operate</p> <p>When Forward Drive Prohibition Input is open: Forward rotation prohibited and reverse rotation permitted</p> <p>When Reverse Drive Prohibition Input is shorted: Normal state in which the reverse limit switch does not operate</p> <p>When Reverse Drive Prohibition Input is open: Reverse rotation prohibited and forward rotation permitted</p> <p>The Servomotor decelerates and stops according to the sequence set in Stop Selection for Drive Prohibition Input (Pn505). For details, refer to explanation for Stop Selection for Drive Prohibition Input (Pn505).</p> <p>If both the Forward and the Reverse Prohibition Input signals are open, Drive Prohibition Input Error (Alarm No. 38.0) will occur because it is taken that Servo Drive is in error condition.</p>
1	Forward and Reverse Drive Prohibition Input function disabled
2	<p>Forward and Reverse Drive Prohibition Input function enabled</p> <p>If either the Forward or Reverse Prohibition Input signal is open, Drive Prohibition Input Error (Alarm No. 38.0) will occur.</p>



Precautions for Correct Use

Both signals are disabled (in a state in which drive prohibition does not operate) in the default settings. If prohibiting the drive input is required, set the Drive Prohibit Input Selection (Pn504) to either 0 or 2. The setting on the Input Signal Selection 1 to 10 (Pn400 to Pn409) can change the logic and allocation for the respective Input terminals (CN1 pins 1 to 8, 9, 26 to 33).

Stop Selection for Drive Prohibition Input (Pn505)

Set the deceleration and stop methods used when the Forward/Reverse Drive Prohibition Input signal turns ON.

Stop Selection for Drive Prohibition Input (Pn505)	Deceleration method	After stopping	Error counter
0	Dynamic brake	Torque command = 0 for drive prohibition direction	Held
1	Free-run (Torque command = 0 for drive prohibition direction)	Torque command = 0 for drive prohibition direction	Held
2	Immediate stop	Servo lock	Cleared before and after deceleration

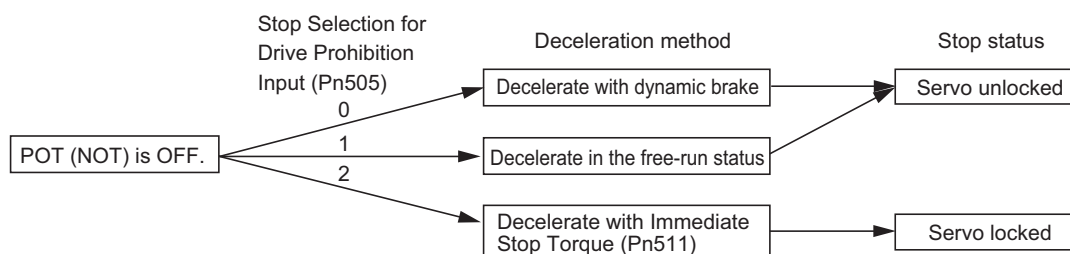

While the Forward Drive Prohibition Input (POT) is OFF, the Servomotor cannot be driven in the forward direction, but it can be driven in the reverse direction. Conversely, while the Reverse Drive Prohibition Input (NOT) is OFF, the Servomotor cannot be driven in the reverse direction, but it can be driven in the forward direction.

If you set the Servomotor to decelerate at the immediate stop torque and stop with servo locked (set value: 2), the torque limit during deceleration will be limited by the value set in Immediate Stop Torque (Pn511).



Precautions for Correct Use

- A load on the vertical axis and so forth may fall due to its own weight when the Drive Prohibition Input is ON. To prevent this, set the Servomotor to decelerate at the immediate stop torque and stop with servo locked (set value: 2) in the Stop Selection for Drive Prohibition Input (Pn505), or limit the operation using the host controller instead of this function.
- Because an immediate stop causes the motor to decelerate quickly, in the position control mode, the position error may become large momentarily, resulting in a Error Counter Overflow (Alarm No. 24.0) or Overrun Limit Error (Alarm No. 34.0). To prevent this, set Error Counter Overflow Level (Pn014) and Overrun Limit Setting (Pn514) to appropriate values.

6-11 Disturbance Observer Function

6-11-1 Outline of the Function

The disturbance observer function enables you to lower the effect of the disturbance torque and reduce vibration by using the estimated disturbance torque value.

You can use the disturbance observer for position control or speed control in the following situations.

- The servo is ON.
- The Servomotor can rotate normally without any failures.
- The realtime autotuning function is disabled.
- The instantaneous speed observer function is disabled.

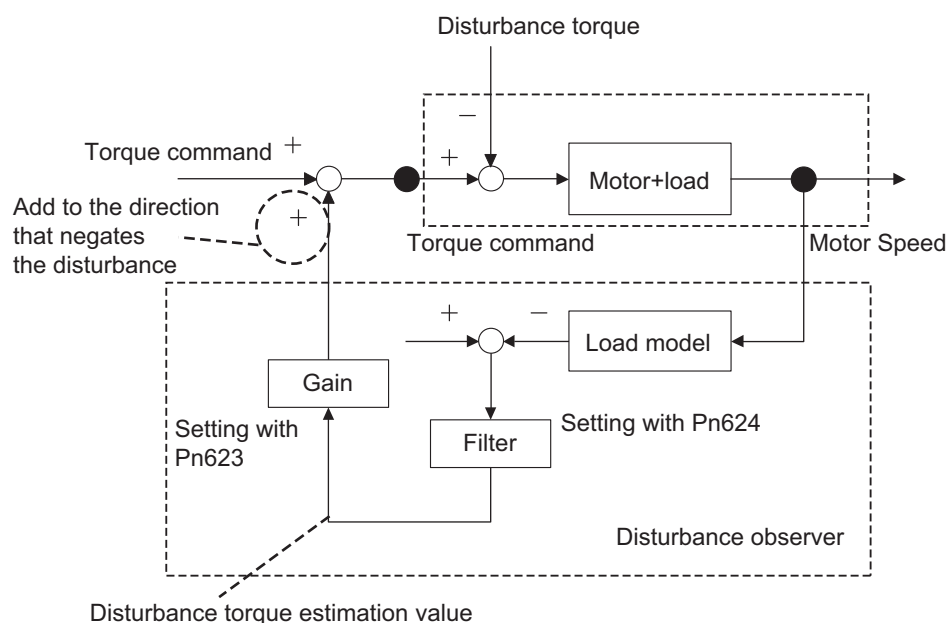

Precautions for Correct Use

If there is a resonance point below the cut-off frequency estimated by the disturbance observer, or if the disturbance torque contains a large amount of high-frequency content, the disturbance observer may not produce the expected results.

6-11-2 Parameters Requiring Settings

Parameter No.	Name	Description	Reference
Pn610	Function Expansion Setting	Set the bits related to the disturbance observer.	P.7-56
Pn623	Disturbance Torque Compensation Gain	Set the compensation gain for the disturbance torque.	P.7-58
Pn624	Disturbance Observer Filter Setting	Set the filter time constant for disturbance torque compensation.	P.7-58

6-11-3 Operating Procedure

1 Set Function Expansion Setting (Pn610).

Set whether to enable or disable the disturbance observer in bit 1.

0: Disabled

1: Enabled

Set the operating conditions for enabling the function in bit 2.

0: Enabled at all time

1: Enabled only when Gain 1 is selected

2 Set Disturbance Observer Filter Setting (Pn624).

Set a small value in Disturbance Torque Compensation Gain (Pn623). Change the value in Disturbance Observer Filter Setting (Pn624) from a large value to a smaller one to determine a setting that provides a balance between the effect of suppressing the influence of disturbance and the operating noise level.

3 Set Disturbance Torque Compensation Gain (Pn623).

Change the value of Disturbance Torque Compensation Gain (Pn623) from a small value to a larger value to determine a setting that provides a balance between the effect of suppressing the influence of disturbance and the operating noise level.

6-12 Gain 3 Switching Function

6-12-1 Outline of the Function

You can newly set Gain 3 right before stopping to the gain switching function in Gain Switching Input Operating Mode Selection (Pn114).

You can use the Gain 3 switching function for position control in the following situations.

- The servo is ON.
- The Servomotor can rotate normally without any failures.

6-12-2 Parameters Requiring Settings

Parameter No.	Name	Description	Reference
Pn605	Gain 3 Effective Time	Set the time during which Gain 3 is enabled.	P.7-55
Pn606	Gain 3 Ratio Setting	Set Gain 3 as a multiple of Gain 1.	P.7-55

6-12-3 Operation

Operation Timings of Gains 1, 2 and 3

Example: Switching Mode in Position Control = 7, Switching Condition = Position Command Input

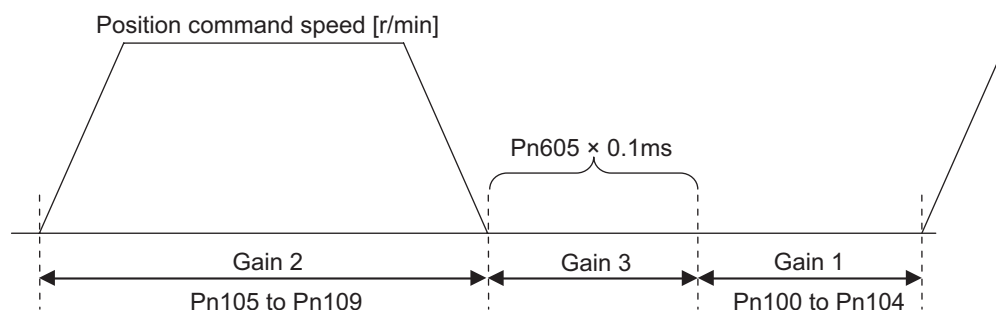

Gain 3 region

Position loop gain = $Pn100 \times Pn606/100$

Speed loop gain = $Pn101 \times Pn606/100$

The Gain 1 values are used for the speed loop integral time constant, speed feedback filter time constant, and force command filter time constant.



Precautions for Correct Use

- If Gain 3 is not used, set both Gain 3 Effective Time (Pn605) and the Gain 3 Ratio Setting (Pn606) to 0.
- In the Gain 3 region, only the position loop gain and the speed loop gain are treated as Gain 3 and the Gain 1 setting is applied to other gains.
- If the Gain 2 switching condition is established in the Gain 3 region, operation switches to Gain 2.
- If Gain 2 switches to Gain 3, the Position Gain Switching Time (Pn119) is enabled.
- There is a Gain 3 region even when Gain 2 is switched to Gain 1 due to a parameter change and so forth.

6-13 Friction Torque Compensation Function

6-13-1 Outline of the Function

The friction torque compensation function reduces the influence of friction. You can set unbalanced load compensation that offsets the constantly applied unbalance torque and dynamic friction compensation that changes the offset direction in accordance with the operating direction.

You can use the friction torque compensation function in the following situations.

- The servo is ON.
- The Servomotor can rotate normally without any failures.

6-13-2 Parameters Requiring Settings

Parameter No.	Name	Description	Reference
Pn607	Torque Command Value Offset	Set the unbalanced load compensation value that is always added to the torque command.	P.7-55
Pn608	Forward Direction Torque Offset	Set the dynamic friction compensation value that is added to the torque command when a forward direction position command is input in the position control mode.	P.7-55
Pn609	Reverse Direction Torque Offset	Set the dynamic friction compensation value that is added to the torque command when a reverse direction position command is input in the position control mode.	P.7-55

6-13-3 Operation Example

Torque Command Value Offset (Pn607) reduces the variations of positioning operations due to the movement directions when a certain amount of unbalanced load torque is always applied to the motor at the vertical axis by setting the torque command value.

By setting the friction torque for each rotation direction in Forward Direction Torque Offset (Pn608) and Reverse Direction Torque Offset (Pn609), you can reduce the deterioration of and inconsistencies in the positioning stabilization time due to dynamic friction for loads that require a large amount of dynamic friction torque due to a radial load, such as the belt-driven shaft.

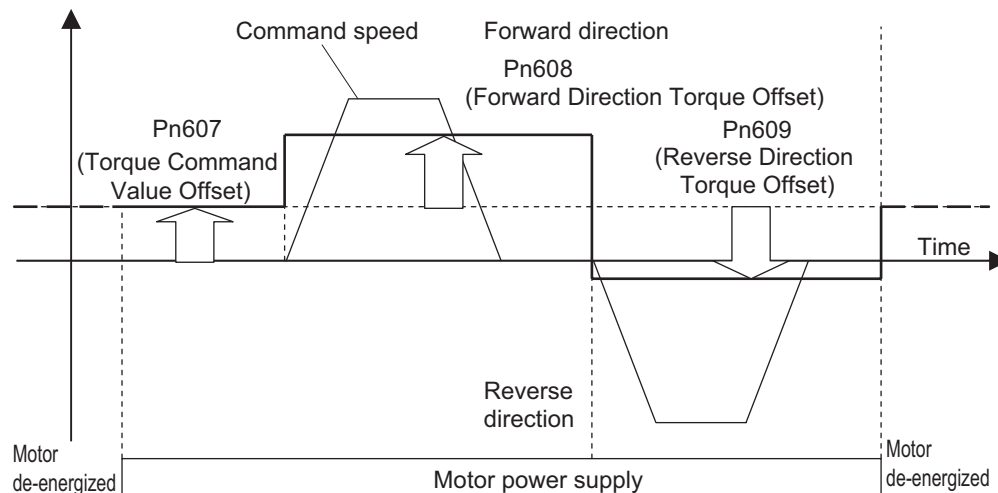

Precautions for Correct Use

You can use unbalanced load compensation and dynamic friction compensation together or separately. Take note that the following use limit is applied upon control mode switching or servo ON.

- When servo is OFF in speed control
Unbalanced load compensation is enabled based on Pn607. Dynamic friction compensation will be 0 regardless of the parameter setting.
- When servo is ON in position control
The unbalanced load compensation and dynamic friction compensation values are held until the first position command is input. Once the position command is input, the unbalanced load compensation value is updated based on Pn607. Also, based on the command direction, the dynamic friction compensation value is updated according to the parameter Pn608 or Pn609.

6-14 Inertia Ratio Switching Function

6-14-1 Outline of the Function

You can switch between the inertia ratio 1 and 2 using Inertia Ratio Switching Input (JSEL). This function is effective if it is used when the load inertia changes in 2 levels.

You can use the inertia ratio switching function in the following situations.

- The servo is ON.
- The Servomotor can rotate normally without any failures.
- The realtime autotuning function is disabled.
- The adaptive filter function is disabled.
- The instantaneous speed observer function is disabled.
- The disturbance observer function is disabled.

6-14-2 Parameters Requiring Settings

Parameter No.	Name	Description	Reference
Pn610	Function Expansion Setting	Set the bits related to the inertia ratio switching function.	P.7-56
Pn004	Inertia Ratio 1	Set the first inertia ratio.	P.7-4
Pn613	Inertia Ratio 2	Set the second inertia ratio.	P.7-56

6-14-3 Operating Procedure

1 Set Function Expansion Setting (Pn610).

Set whether to enable or disable inertia ratio switching function in bit 3.

0: Disabled

1: Enabled

2 Set Inertia Ratio 1 (Pn004).

3 Set Inertia Ratio 2 (Pn613).

4 Set the Inertia Ratio Switching Input (JSEL) signal.

Function Expansion Setting (Pn610)	Inertia Ratio Switching Input (JSEL)	Applicable inertia ratio
bit 3 = 0: Inertia ratio switching function disabled	OFF	Inertia Ratio 1 (Pn004)
	ON	
bit 3 = 1: Inertia ratio switching function enabled	OFF	Inertia Ratio 2 (Pn613)
	ON	



Precautions for Correct Use

- Be sure to switch the inertia ratio with the Servomotor stopped.
- Vibration may occur even when the Servomotor is stopped if the values set in Inertia Ratio 1 and Inertia Ratio 2 differ significantly. Before using the Servomotor, check to be sure that the vibration causes no problem.

6-15 Feed-forward Function

6-15-1 Outline of the Function

The feed-forward function comes in 2 types: speed feed-forward and torque feed-forward.

Speed feed-forward can minimize the position error and improve the responsiveness in the position control mode by calculating the speed control command required for operation from the internal position command and then adding it to the speed command calculated by comparison with the position feedback value.

By contrast, torque feed-forward improves the responsiveness in the speed control mode by calculating the torque command required for operation from the speed control command and then adding it to the torque command calculated by comparison with the speed feedback value.

6-15-2 Parameters Requiring Settings

Parameter No.	Name	Description	Reference
Pn110	Speed Feed-forward Amount	The speed control command value calculated from the internal position command is multiplied by the ratio set in this parameter and added to the speed command value from the position control process.	P.7-13
Pn111	Speed Feed-forward Command Filter	Set the time constant for the first-order lag filter that is applied to speed feed-forward input.	P.7-13
Pn112	Torque Feed-forward Amount	The torque command value calculated from the speed control command is multiplied by the ratio set in this parameter and added to the torque command value from the speed control process.	P.7-13
Pn113	Torque Feed-forward Command Filter	Set the time constant for the first-order lag filter that is applied to torque feed-forward input.	P.7-13
Pn610	Function Expansion Setting	Set the bits related to the inertia ratio switching function.	P.7-56

6-15-3 Operating Procedure

Speed Feed-forward Operating Method

1 Set Speed Feed-forward Command Filter (Pn111).

Set this to approximately 50 (0.5 ms).

2 Adjust Speed Feed-forward Amount (Pn110).

Gradually increase the value set in Speed Feed-forward Amount (Pn110) and finely adjust it to avoid overshooting during acceleration/deceleration.

If Speed Feed-forward Amount is set to 100%, the position error is calculated as 0. However, large overshooting will occur during acceleration/deceleration.

The position error when the Servomotor is operating at a constant speed will decrease based on the following formula according to the speed feed-forward gain value.

$$\text{Position error [command units]} = \frac{\text{Command speed [command units/s]} \times \text{Position Loop Gain [1/s]}}{(100 - \text{Speed Feed-forward Amount [\%]})/100}$$

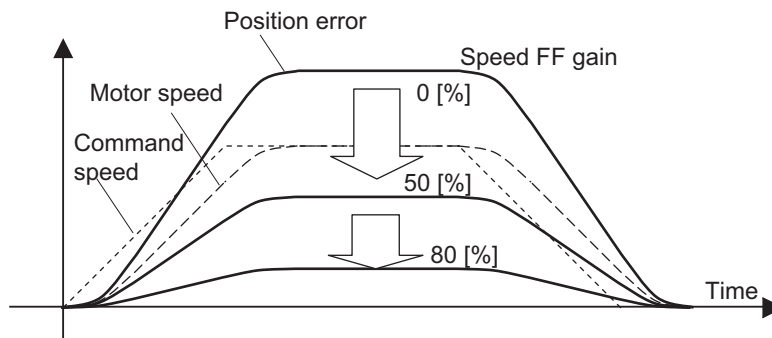

The position error in the constant speed range becomes smaller as the speed feed-forward gain increases.



Precautions for Correct Use

If the update cycle of the position command input is longer than the Servo Drive control cycle, or if the pulse frequency is not uniform, operating noise may increase while the speed feed-forward is enabled. Apply the position command filter (first-order lag or FIR smoothing) or increase the speed feed-forward filter value.

Torque Feed-forward Operating Method

1 Set Inertia Ratio 1 (Pn004).

Set the inertia ratio as correctly as possible.

- If the inertia ratio is calculated for the selected motor, input the calculated value.
- If the inertia ratio is not known, perform autotuning and set the inertia ratio.

2 Set Torque Feed-forward Command Filter (Pn113).

Set this to approximately 50 (0.5 ms).

3 Adjust Torque Feed-forward Amount (Pn112).

Gradually increase the value of Torque Feed-forward Gain (Pn112).

Since the position error during acceleration/deceleration at a constant speed can be brought close to 0, it can be controlled to almost 0 throughout the entire operation range during a trapezoidal speed pattern under ideal conditions where no disturbance torque is working. In reality, disturbance torque is always applied and, therefore, the position error cannot be completely 0.

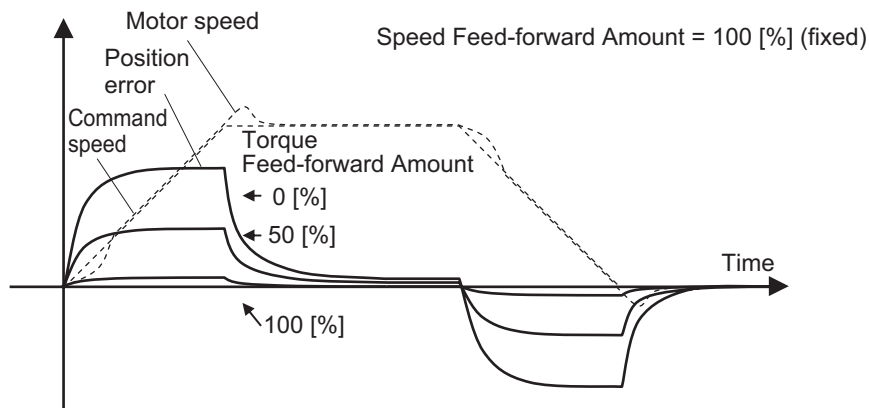

Torque feed-forward can reduce the position error in the range of constant acceleration/deceleration.



Precautions for Correct Use

If you increase the torque feed-forward filter time constant, operating noise will be reduced. However, the position error at the acceleration change point will become larger.

6-16 Instantaneous Speed Observer Function

6-16-1 Outline of the Function

The instantaneous speed observer function uses a load inertia to estimate the motor speed. This improves the speed detection accuracy and can provide both high responsiveness and minimum vibration when stopping. This function is available in the position control mode.

You can use the instantaneous speed observer function in the following situations.

- The servo is ON.
- The Servomotor can rotate normally without any failures.
- The realtime autotuning function is disabled.

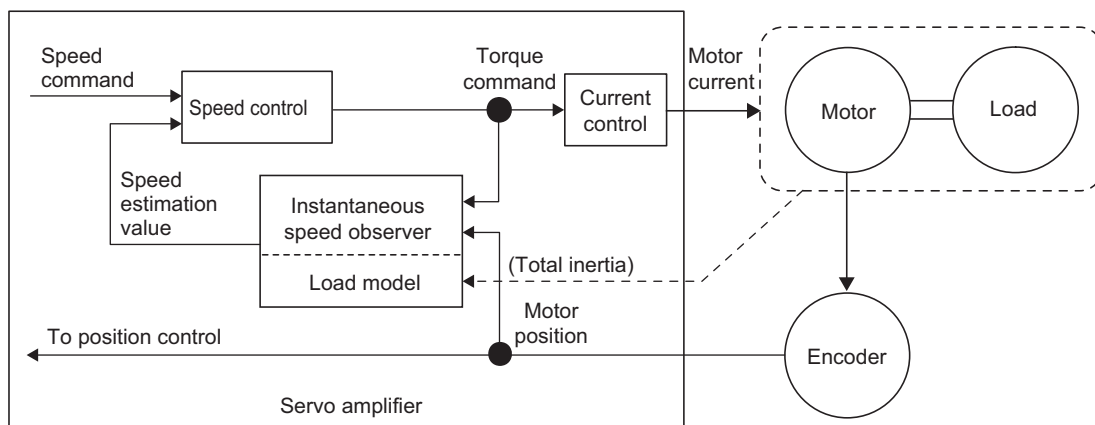

6-16-2 Parameters Requiring Settings

Parameter No.	Name	Description	Reference
Pn610	Function Expansion Setting	Set whether to enable or disable the instantaneous speed observer function.	P.7-56
Pn004	Inertia Ratio 1	Set the first inertia ratio.	P.7-4
Pn100	Position Loop Gain	Set the position loop gain.	P.7-10
Pn101	Speed Loop Gain	Set the speed loop gain.	P.7-11

6-16-3 Operating Procedure

1 Set Inertia Ratio 1 (Pn004).

Set the inertia ratio as correctly as possible.

- If Inertia Ratio 1 (Pn004) is obtained in realtime auto gain tuning, use the set value as is.
- If the inertia ratio is calculated for the selected motor, input the calculated value.
- If the inertia ratio is not known, perform autotuning and set the inertia ratio.

2 Adjust the position loop gain and the speed loop gain.

Adjust Position Loop Gain (Pn100), Speed Loop Gain (Pn101), Speed Loop Integral Time Constant (Pn102), and Torque Command Filter Time Constant (Pn104).

If no problem occurs in realtime autotuning, you can continue to use the settings.

3 Set Function Expansion Setting (Pn610).

Set whether to enable or disable the instantaneous speed observer function in bit 0.

0: Disabled

1: Enabled

If you set this to 1 (enabled), the speed detection method switches to the instantaneous speed observer.

- If the machine operating noise or vibration increases, or fluctuations in the torque monitor waveform increase significantly enough to cause a problem, return the setting to 0 and make sure that the inertia ratio or the adjustment parameters are correct.
- If the machine operating noise or vibration decreases, or fluctuations in the torque monitor waveform decrease, make small adjustments to Inertia Ratio 1 (Pn004) to find the setting that makes the smallest fluctuations, while monitoring the position error waveform and the actual speed waveform.
- If Position Loop Gain (Pn100), Speed Loop Gain (Pn101), or Speed Loop Integral Time Constant (Pn102) is changed, the optimal value for Inertia Ratio 1 (Pn004) may change, so make small adjustments to the value in Inertia Ratio 1 (Pn004) again to set a value that makes the smallest fluctuations.



Precautions for Correct Use

Damping control may not function properly or have no effect under the following conditions.

- The margin of error with the actual device is large for the inertia load.
- Equipment has more than one resonance frequency.
- There is a large resonance point at a frequency of 300 Hz or lower.
- There is a non-linear element (play), such as a large backlash.
- The load inertia changes.
- A large disturbance torque with high-frequency content is applied.
- The positioning setting range is small.



Parameter Details

This section explains the set value and setting details of each parameter.

7-1 Basic Parameters	7-2
7-2 Gain Parameters	7-10
7-3 Vibration Suppression Parameters	7-20
7-4 Analog Control Parameters	7-26
7-5 Interface Monitor Setting Parameters	7-32
7-6 Extended Parameters	7-42
7-7 Special Parameters	7-55

7-1 Basic Parameters

Pn000	Rotation Direction Switching						All
Setting range	0 to 1	Unit	–	Default setting	1	Cycle the power supply	Required

Explanation of Set Values

Set value	Description
0	Forward direction command sets the motor rotation direction to CW.
1	Forward direction command sets the motor rotation direction to CCW.

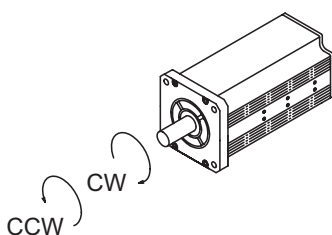

- Regarding the rotation direction of the Servomotor, a clockwise rotation is defined as CW and a counterclockwise rotation is defined as CCW, when viewed from the load-side shaft. The following table shows the motor rotation direction for the command.

Pn000	Pn006	Pn301	Command	Servomotor rotation direction
0	0	–	CCW pulse	CCW: Forward
	0	–	CW pulse	CW: Reverse
	1	–	CCW pulse	CW: Reverse
	1	–	CW pulse	CCW: Forward
	–	0	Positive (+) internal speed	CCW: Forward
	–	0	Negative (–) internal speed	CW: Reverse
	–	1	Positive (+) internal speed	CW: Reverse
	–	1	Negative (–) internal speed	CCW: Forward
1	0	–	CCW pulse	CW: Reverse
	0	–	CW pulse	CCW: Forward
	1	–	CCW pulse	CCW: Forward
	1	–	CW pulse	CW: Reverse
	–	0	Positive (+) internal speed	CW: Reverse
	–	0	Negative (–) internal speed	CCW: Forward
	–	1	Positive (+) internal speed	CCW: Forward
	–	1	Negative (–) internal speed	CW: Reverse

Pn001	Control Mode Selection						All
Setting range	0 to 6	Unit	–	Default setting	0	Cycle the power supply	Required

Explanation of Set Values

Set value	Description
0	Position control (Pulse-train command)
1	Speed control (Internally set speed control)
2	Reserved (Do not set.)
3	Mode 1: Position control, Mode 2: Speed control (Internally set speed control)
4	Reserved (Do not set.)
5	Reserved (Do not set.)
6	Reserved (Do not set.)

- Set the control mode to be used.
- Selecting the combined mode (set value: 3) enables the selection of Mode 1 or Mode 2 based on the Control Mode Switching Input (TVSEL).
 - If Control Mode Switching Input is open: Mode 1 is selected.
 - If Control Mode Switching Input is shorted: Mode 2 is selected.
- Do not input commands during 10 ms before and after mode switching operation.

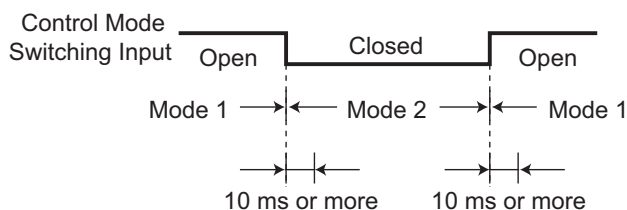

Pn002	Realtime Autotuning Mode Selection						All
Setting range	0 to 6	Unit	–	Default setting	1	Cycle the power supply	–

Explanation of Set Values

Set value	Description
0	Disabled
1	Focus on stability
2	Focus on positioning
3	Used when unbalanced load is present, i.e., with a vertical axis, etc.
4	Used when a vertical axis or other unbalanced load is present and when friction is large.
5	Used only for estimating load characteristics.
6	Used for customizing the realtime autotuning mode.

- Set the realtime autotuning operation mode.

Pn003	Realtime Autotuning Machine Rigidity Setting						All
Setting range	0 to 31	Unit	–	Default setting	13 ^{*1}	Cycle the power supply	–

*1 The default setting is 11 for a Servo Drive with 200 V and 1 kW or more.

- Set the machine rigidity in 32 levels when realtime autotuning is enabled.

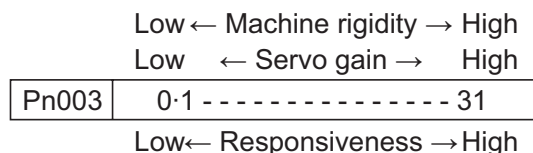

- Increasing or decreasing the set value too much at a time may cause the gain to change rapidly, which applies an impact on the machine. Always start with a small value, and gradually increase it while monitoring machine operation.

Pn004	Inertia Ratio 1						All
Setting range	0 to 10,000	Unit	%	Default setting	250	Cycle the power supply	–

- Set the load inertia as a percentage of the motor rotor inertia.
- $Pn004 = (\text{Load inertia} / \text{Rotor inertia}) \times 100\%$
- When realtime autotuning is enabled, the inertia ratio is continuously estimated and saved to the EEPROM every 30 minutes.
- When the inertia ratio is set correctly, the setting unit for Speed Loop Gain (Pn101) and Speed Loop Gain 2 (Pn106) is Hz.
- If Inertia Ratio 1 (Pn004) is set larger than the actual value, the setting unit for speed loop gain is larger. If Inertia Ratio 1 (Pn004) is set smaller than the actual value, the setting unit for speed loop gain is smaller.

Pn005	Command Pulse Input Selection						Position
Setting range	0 to 1	Unit	–	Default setting	0	Cycle the power supply	Required

Explanation of Set Values

Set value	Description
0	Photocoupler input (+PULS: CN1 pin 3, –PULS: CN1 pin 4, +SIGN: CN1 pin 5, –SIGN: CN1 pin 6)
1	Input for line driver only (+CWLD: CN1 pin 44, –CWLD: CN1 pin 45, +CCWLD: CN1 pin 46, –CCWLD: CN1 pin 47)

- Select whether to use photocoupler input or input for line driver only for command pulse input.

Pn006	Command Pulse Rotation Direction Switching Selection						Position
Setting range	0 to 1	Unit	–	Default setting	0	Cycle the power supply	Required

Explanation of Set Values

Set value	Description
0	The Servomotor rotates according to the command pulse direction.
1	The Servomotor rotates opposite to the command pulse direction.

- Set the direction in which the Servomotor rotates in response to command pulse input.

Pn007	Command Pulse Mode Selection					Position
Setting range	0 to 3	Unit	–	Default setting	1	Cycle the power supply Required

- Set the count method for the command pulse input.

Command Pulse Rotation Direction Switching Selection (Pn006)	Command Pulse Mode Selection (Pn007)	Command pulse mode	Motor forward command	Motor reverse command
0	0 or 2	90° phase difference (A/B) signal input	<p>Line driver: $t_1 \geq 2 \mu\text{s}$ Open collector: $t_1 \geq 5 \mu\text{s}$</p>	
	1	Reverse pulse/ Forward pulse	<p>Line driver: $t_2 \geq 1 \mu\text{s}$ Open collector: $t_2 \geq 2.5 \mu\text{s}$</p>	
	3	Feed pulse/ Forward or reverse signal	<p>Line driver: $t_2 \geq 1 \mu\text{s}$ Open collector: $t_2 \geq 2.5 \mu\text{s}$</p>	

Command Pulse Rotation Direction Switching Selection (Pn006)	Command Pulse Mode Selection (Pn007)	Command pulse mode	Motor forward command	Motor reverse command
1	0 or 2	90° phase difference (A/B) signal input	<p>Line driver: $t1 \geq 2 \mu s$ Open collector: $t1 \geq 5 \mu s$</p>	
	1	Reverse pulse/ Forward pulse	<p>Line driver: $t2 \geq 1 \mu s$ Open collector: $t2 \geq 2.5 \mu s$</p>	
	3	Feed pulse/ Forward or reverse signal	<p>Line driver: $t2 \geq 1 \mu s$ Open collector: $t2 \geq 2.5 \mu s$</p>	

- Set the input pattern of the command pulses from the position controller to the Servo Drive.

Pn008	Electronic Gear Integer Setting						Position
Setting range	0 to 2^{20}	Unit	pulses	Default setting	10,000	Cycle the power supply	Required

- Set the number of command pulses per motor rotation.
- When this parameter is set to 0, Electronic Gear Ratio Numerator 1 (Pn009) and Electronic Gear Ratio Denominator (Pn010) are enabled.

Pn009	Electronic Gear Ratio Numerator 1						Position
Setting range	0 to 2^{30}	Unit	–	Default setting	0	Cycle the power supply	–

Pn010	Electronic Gear Ratio Denominator						Position
Setting range	1 to 2^{30}	Unit	–	Default setting	10,000	Cycle the power supply	–

- Set the electronic gear function.
 - These parameters are enabled when Pn008 is set to 0.
- Intended use of the electronic gear function:
 - Set the desired number of motor/Electronic Gear Ratio Denominator per unit number of input command pulses.
 - This parameter is used to increase the apparent command pulse frequency with the multiplication function if the required motor speed cannot be obtained due to the limitation of the pulse oscillation capacity (i.e., maximum allowable output frequency) of the host system.
- Block diagram of the electronic gear function:

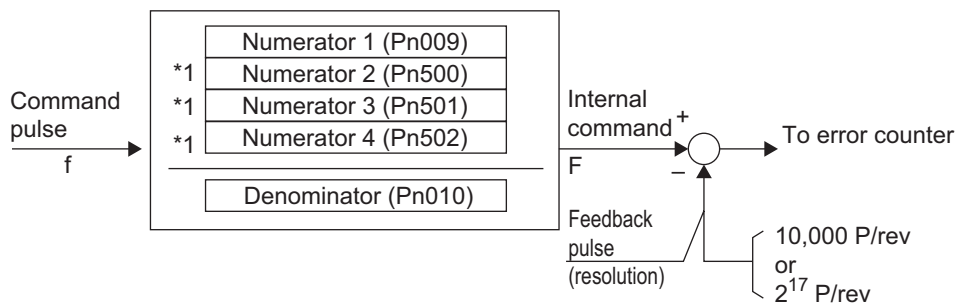

- *1 The selection of second to fourth numerators is made based on the Electronic Gear Switching 1 and 2 (GESEL1 and GESEL2) settings.

GESEL1	GESEL2	Selected numerator
OFF	OFF	Electronic Gear Ratio Numerator 1
ON	OFF	Electronic Gear Ratio Numerator 2
OFF	ON	Electronic Gear Ratio Numerator 3
ON	ON	Electronic Gear Ratio Numerator 4

Although Pn008, Pn009, and Pn010 can be set to any value within the setting range, OMRON will not guarantee that the function operates as intended with any extreme electronic gear ratio setting. It is recommended that the electronic gear ratio be used between 1/1,000 and 1,000.

For the setting method, refer also to 6-4 *Electronic Gear Function* on page 6-11.

Pn011	Encoder Dividing Numerator						All
Setting range	1 to 262,144	Unit	P/r	Default setting	2,500	Cycle the power supply	Required



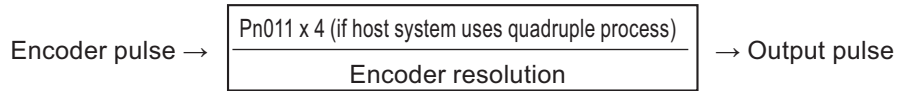





- When Encoder Dividing Denominator (Pn503) is set to 0, the encoder resolution is used as the denominator for dividing the pulse output.



Pn012	Encoder Output Direction Switching Selection						All
Setting range	0 to 1	Unit	–	Default setting	0	Cycle the power supply	Required

- Select the combination of the phase-B logic and the output source for pulse output. Select Encoder as the output source.

Explanation of Set Values

Set value	Phase-B logic	Output source	Motor forward command	Motor reverse command
0	Not reversed	Encoder	Phase A  Phase B 	Phase A  Phase B 
1	Reversed	Encoder	Phase A  Phase B 	Phase A  Phase B 
2 Reserved	–	–		
3 Reserved	–	–		

Pn013	No. 1 Torque Limit						All
Setting range	0 to 500	Unit	%	Default setting	500	Cycle the power supply	–

- Set the first output torque limit of the Servomotor.

Pn014	Error Counter Overflow Level						Position
Setting range	0 to 2 ²⁷	Unit	Command units	Default setting	100,000	Cycle the power supply	–

- Set the range of the error counter overflow level.

Pn015	Reserved						
Setting range	1	Unit	–	Default setting	1	Cycle the power supply	–

- Do not set.

Pn016	Regeneration Resistor Selection						All
Setting range	0 to 3	Unit	–	Default setting	3 ^{*1}	Cycle the power supply	Required

*1 The default setting is 0 for a Servo Drive with 200 V and 750 W or more.

Explanation of Set Values

Set value	Description
0	Regeneration Resistor used: Built-in Resistor The regeneration processing circuit operates and Regeneration Overload (Alarm No. 18) operates according to the Built-in Resistor (with approx. 1% duty).
1	Regeneration Resistor used: External Resistor The regeneration processing circuit operates and Regeneration Overload (Alarm No.18) causes a trip when the operating rate of the Regeneration Resistor exceeds 10%.
2	Regeneration Resistor used: External Resistor The regeneration processing circuit operates, but Regeneration Overload (Alarm No. 18) does not operate.
3	Regeneration Resistor used: None The regeneration processing circuit and Regeneration Overload (Alarm No. 18) do not operate, and all regenerative energy is processed by the built-in capacitor.

- Do not touch the External Regeneration Resistor. The External Regeneration Resistor will become hot and burn injury may result.
- Always provide a temperature fuse or other protective measure when using an External Regeneration Resistor. Regardless of whether the regeneration overload is enabled or disabled, the Regeneration Resistor can generate heat and may cause burning.
- Use this parameter to select whether to use the Built-in Regeneration Resistor as is or use an External Regeneration Resistor (connected to the External Regeneration Resistor connector) with the Built-in Regeneration Resistor disconnected.
- To use the Built-in Regeneration Resistor, always set this parameter to 0.

Pn017	External Regeneration Resistor Setting						All
Setting range	0 to 4	Unit	–	Default setting	0	Cycle the power supply	Required

Explanation of Set Values

Set value	Description
0	Regeneration load ratio is 100% when the operating rate of the External Regeneration Resistor is 10%.
1	Reserved
2	Reserved
3	Reserved
4	Reserved

7-2 Gain Parameters

Pn100	Position Loop Gain						Position
Setting range	0 to 30,000	Unit	0.1/s	Default setting	480 ^{*1}	Cycle the power supply	–

*1 The default setting is 320 for a Servo Drive with 200 V and 1 kW or more.

- Adjust the position loop response in accordance with the machine rigidity.
- The responsiveness of the servo system is determined by the position loop gain. Servo systems with a high position loop gain have a high responsiveness and fast positioning. To increase the position loop gain, you must improve machine rigidity and increase the specific damping frequency. This should be 500 to 700 (0.1/s) for ordinary machine tools, 300 to 500 (0.1/s) for general-use and assembly machines, and 100 to 300 (0.1/s) for industrial robots. The default position loop gain is 400 (0.1/s), so be sure to lower the set value for machines with low machine rigidity.
- Increasing the position loop gain in systems with low machine rigidity or systems with low specific damping frequencies may cause mechanical resonance, resulting in an overload alarm.
- If the position loop gain is low, you can shorten the positioning time using feed-forward.
- This parameter is automatically changed by the realtime autotuning function. For manual adjustment, set Realtime Autotuning Mode Selection (Pn002) to 0.

Position loop gain is generally expressed as follows:

$$\text{Position loop gain (Kp)} = \frac{\text{Command pulse frequency (pulses/s)}}{\text{No. of error pulses accumulated in error counter}} \quad (0.1/s)$$

Response for Position Loop Gain Changes

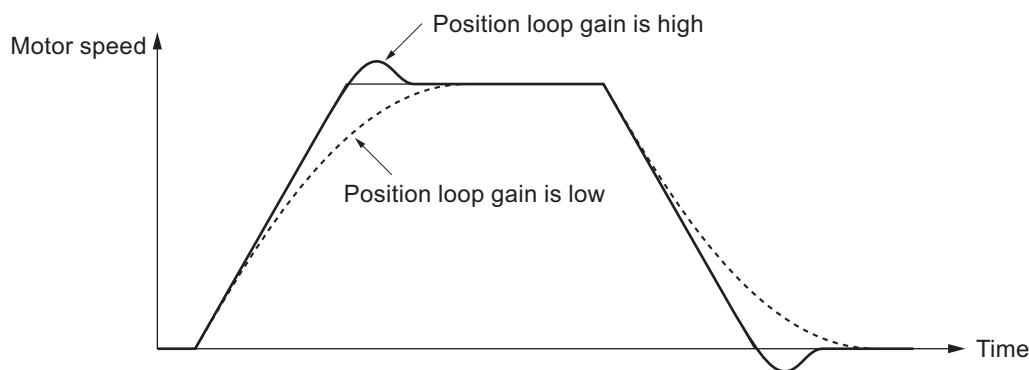

- If the speed loop gain and position loop gain are optimally set, the motor operation delays $2/Kp$ for acceleration and $3/Kp$ for deceleration in response to command input.

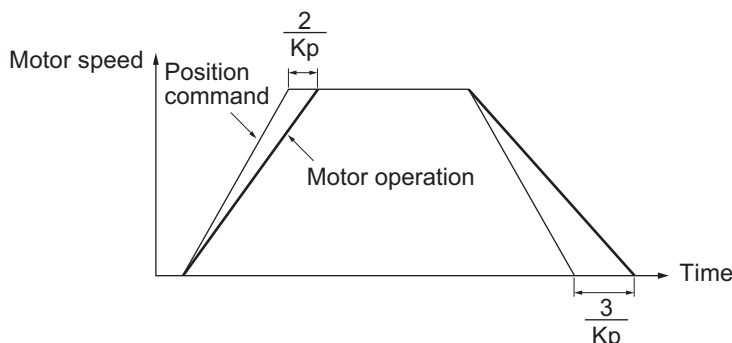

Pn101	Speed Loop Gain						All
Setting range	1 to 32,767	Unit	0.1 Hz	Default setting	270 ^{*1}	Cycle the power supply	–

*1 The default setting is 180 for a Servo Drive with 200 V and 1 kW or more.

- This parameter determines speed loop responsiveness.
- The setting for the speed loop gain must be increased to increase the position loop gain and improve the responsiveness of the entire servo system. Setting it too high, however, may result in vibration.
- The setting unit for Pn101 is Hz when Inertia Ratio 1 (Pn004) is set correctly.

Response for Speed Loop Gain Changes

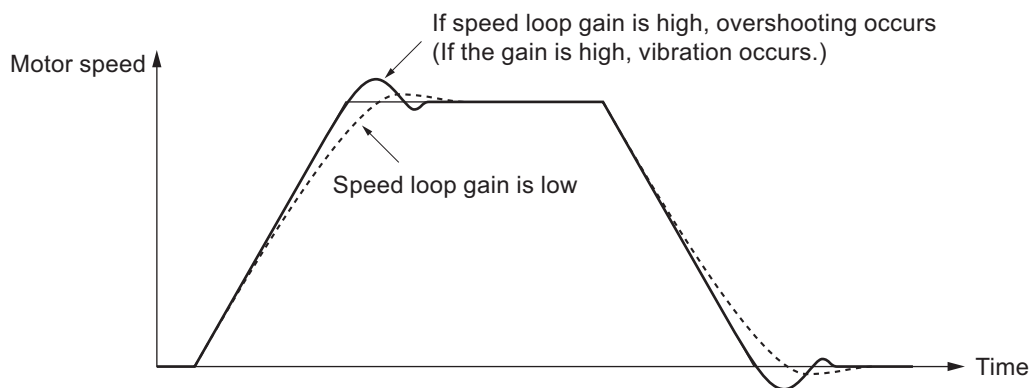

Pn102	Speed Loop Integral Time Constant						All
Setting range	1 to 10,000	Unit	0.1 ms	Default setting	210 ^{*1}	Cycle the power supply	–

*1 The default setting is 310 for a Servo Drive with 200 V and 1 kW or more.

- Set the speed loop integral time constant.
- The smaller the set value, the faster the error approaches 0 when stopping. When set to 9,999, the effect of integration will be held. However, it will be lost when set to 10,000.

Response for Speed Loop Integral Time Constant

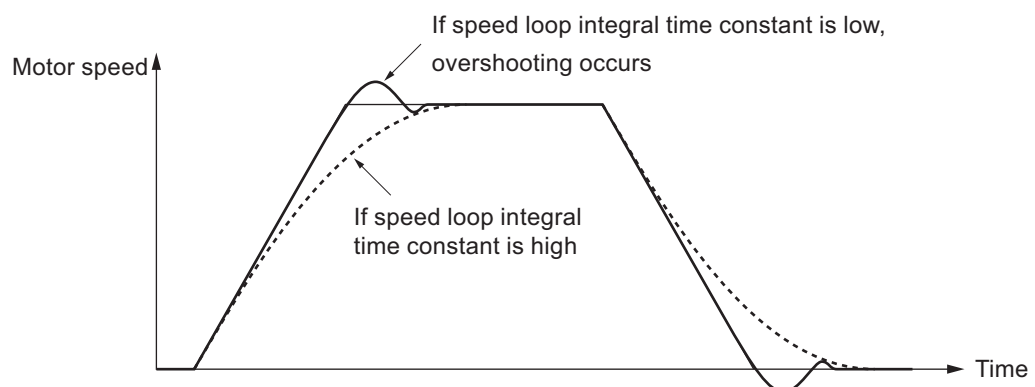

Pn103	Speed Feedback Filter Time Constant						All
Setting range	0 to 5	Unit	–	Default setting	0	Cycle the power supply	–

- Set the time constant for the low pass filter (LPF) after speed detection in six levels (0 to 5).
- Increasing the set value increases the time constant and decreases the noise generated by the Servomotor. Responsiveness, however, also decreases.
- Normally, use the default set value.

Pn104	Torque Command Filter Time Constant						All
Setting range	0 to 2,500	Unit	0.01 ms	Default setting	84 ^{*1}	Cycle the power supply	–

- *1 The default setting is 126 for a Servo Drive with 200 V and 1 kW or more.
- Set the time constant for the first-order lag filter inserted into the torque command.
- This parameter may be effective in suppressing vibration due to torsion resonance.

Pn105	Position Loop Gain 2						Position
Setting range	0 to 30,000	Unit	0.1/s	Default setting	570 ^{*1}	Cycle the power supply	–

- *1 The default setting is 380 for a Servo Drive with 200 V and 1 kW or more.
- Set the responsiveness of the position control system for the second position loop.

Pn106	Speed Loop Gain 2						All
Setting range	1 to 32,767	Unit	0.1 Hz	Default setting	270 ^{*1}	Cycle the power supply	–

- *1 The default setting is 180 for a Servo Drive with 200 V and 1 kW or more.
- Set the responsiveness of the second speed loop.

Pn107	Speed Loop Integral Time Constant 2						All
Setting range	1 to 10,000	Unit	0.1 ms	Default setting	10,000	Cycle the power supply	–

- Set the second speed loop integral time constant.

Pn108	Speed Feedback Filter Time Constant 2						All
Setting range	0 to 5	Unit	–	Default setting	0	Cycle the power supply	–

- Set the second speed feedback filter.

Pn109	Torque Command Filter Time Constant 2						All
Setting range	0 to 2,500	Unit	0.01 ms	Default setting	84 ^{*1}	Cycle the power supply	–

- *1 The default setting is 126 for a Servo Drive with 200 V and 1 kW or more.
- Set the second torque filter time constant.
- The parameters from Pn105 to Pn109 are the gain and time constants to be selected when Gain Switching Input Operating Mode Selection (Pn114) is enabled.
- The gain is switched according to the condition set in the Switching Mode parameters (Pn115 and Pn120).
- If the mechanical system inertia changes greatly or if you want to change the responsiveness depending on whether the Servomotor is rotating or stopped, you can have appropriate control by setting the gains and time constants beforehand for each of these conditions, and switching them according to the condition.
- This parameter is automatically changed by the realtime autotuning function. For manual adjustment, set Realtime Autotuning Mode Selection (Pn002) to 0.

Pn110	Speed Feed-forward Amount						Position
Setting range	0 to 1,000	Unit	0.1%	Default setting	300	Cycle the power supply	–

- Set the feed-forward amount. Increasing the set value decreases the position error and increases the responsiveness. Overshooting, however, will occur more easily.

Pn111	Speed Feed-forward Command Filter						Position
Setting range	0 to 6,400	Unit	0.01 ms	Default setting	50	Cycle the power supply	–

- Set the time constant for the first-order lag filter inserted into the feed-forward section.
- When the feed-forward value is set high to cause overshooting of speed or a large noise during operation, setting this filter may provide improvements.

Pn112	Torque Feed-forward Amount						Position	Speed
Setting range	0 to 1,000	Unit	0.1%	Default setting	0	Cycle the power supply	–	

- Set the feed-forward gain in torque control. Increasing the set value decreases the position error and increases the responsiveness. Overshooting, however, will occur more easily.

Pn113	Torque Feed-forward Command Filter						Position	Speed
Setting range	0 to 6,400	Unit	0.01 ms	Default setting	0	Cycle the power supply	–	

- Set the time constant for the first-order lag filter inserted into the feed-forward section.
- When the feed-forward value is set high to cause overshooting of speed or a large noise during operation, setting this filter may provide improvements.

Pn114	Gain Switching Input Operating Mode Selection						All
Setting range	0 to 1	Unit	–	Default setting	1	Cycle the power supply	–

Explanation of Set Values

Set value	Description
0	Gain 1 (PI/P switching enabled)
1	Gain 1/Gain 2 switching enabled

- Select either PI/P operation switching or Gain 1/Gain 2 switching.
- The PI/P operation switching is performed with the Gain Switching (GSEL: CN1 pin 27). However, this setting is fixed to PI when Torque Limit Selection (Pn521) is set to 3.

Gain input	Speed loop operation
COM and open	PI operation
Connection with COM	P operation

- Refer to 6-7 *Gain Switching Function* on page 6-23 for the Gain 1/Gain 2 switching.

Pn115	Switching Mode in Position Control						Position
Setting range	0 to 10	Unit	–	Default setting	0	Cycle the power supply	–

Explanation of Settings

(√: Enabled, –: Disabled)

Set value	Description			
	Gain switching conditions	Gain Switching Delay Time in Position Control (Pn116) ^{*1}	Gain Switching Level in Position Control (Pn117)	Gain Switching Hysteresis in Position Control (Pn118) ^{*2}
0	Always Gain 1 (Pn100 to Pn104).	–	–	–
1	Always Gain 2 (Pn105 to Pn109).	–	–	–
2	Switching using gain switching input (GSEL) for CN1 pin 27	–	–	–
3	Amount of change in torque command (Refer to Figure A.)	√	√ ^{*3} (0.05%)	√ ^{*3} (0.05%)
4	Always Gain 1 (Pn100 to Pn104).	–	–	–
5	Command speed (Refer to Figure B.)	√	√ [r/min]	√ [r/min]
6	Amount of position error (Refer to Figure C.)	√	√ ^{*4} [Pulse]	√ ^{*4} [Pulse]
7	Command pulse input (Refer to Figure D.)	√	–	–
8	Positioning completion output (INP1) OFF (Refer to Figure E.)	√	–	–
9	Actual motor speed (Refer to Figure B.)	√	√ [r/min]	√ [r/min]
10	Combination of command pulse input and motor speed (Refer to Figure F.)	√	√ ^{*5} [r/min]	√ ^{*5} [r/min]

- Select the conditions for switching between Gain 1 and Gain 2 when Gain Switching Input Operating Mode Selection (Pn114) is set to 1.
- This setting is fixed to Gain 1 regardless of the gain input, when Switching Mode in Position Control (Pn115) is set to 1 and Torque Limit Selection (Pn521) is set to 3 or 6.

*1 Gain Switching Delay Time in Position Control (Pn116) becomes effective when the gain is switched from 2 to 1.

*2 The definition of Gain Switching Hysteresis in Position Control (Pn118) is shown in the drawing below.

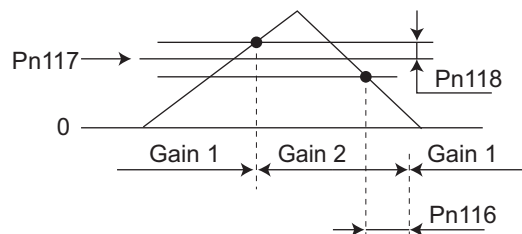

*3 This represents the amount of change during the period of 1 ms.

Example: To switch the gain if the torque variation during 1 ms is 10%, set these parameters to 200.

*4 This represents the encoder resolution.

*5 When the set value is 10, the meanings of Gain Switching Delay Time in Position Control, Gain Switching Level in Position Control, and Gain Switching Hysteresis in Position Control differ from the normal case. (Refer to Figure F.)

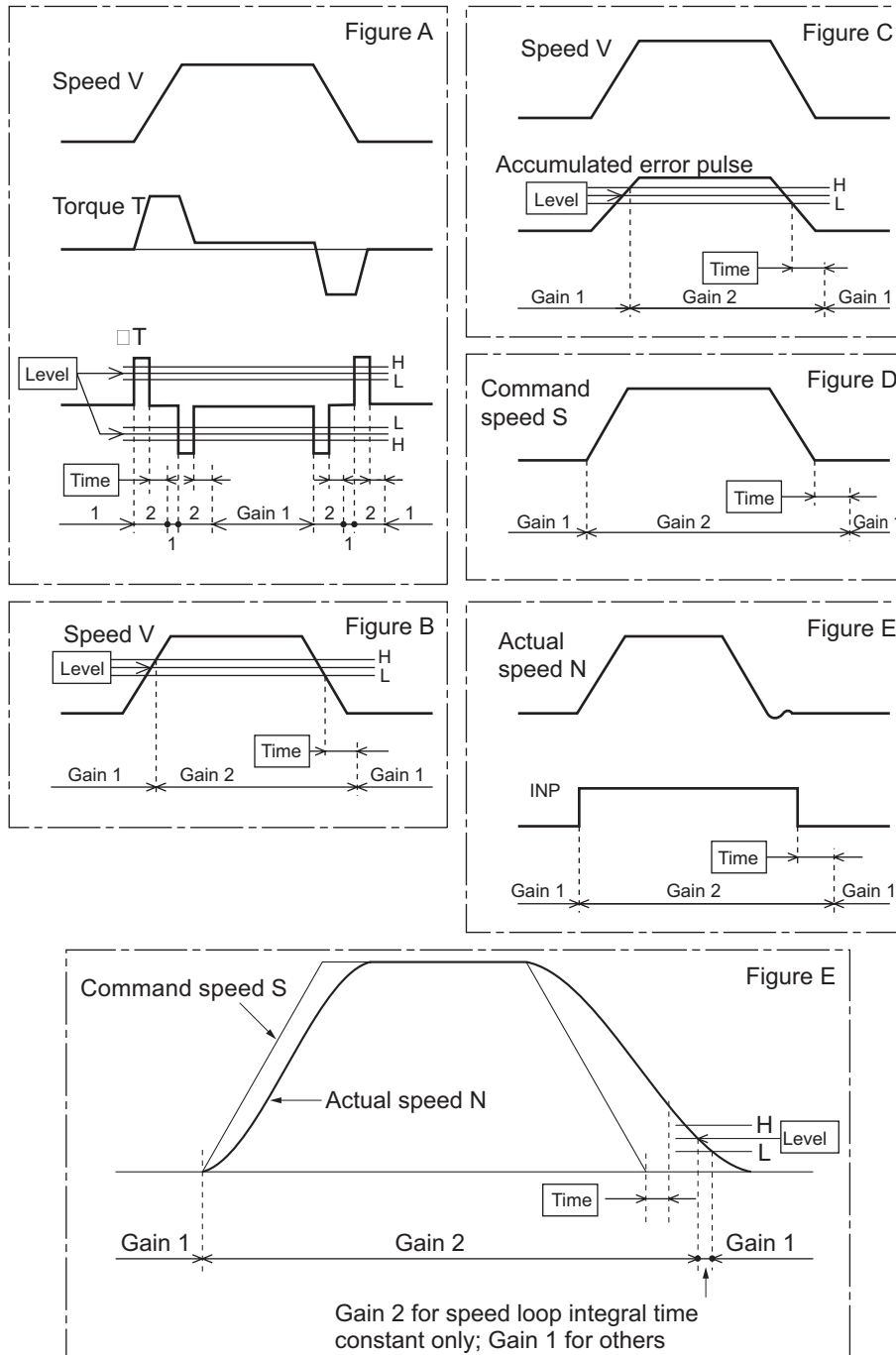

Pn116	Gain Switching Delay Time in Position Control					Position	
Setting range	0 to 10,000	Unit	0.1 ms	Default setting	50	Cycle the power supply	-

- Set the delay time when returning from Gain 2 to Gain 1 if Switching Mode in Position Control (Pn115) is set to 3 or 5 to 10.

Pn117	Gain Switching Level in Position Control						Position
Setting range	0 to 20,000	Unit	–	Default setting	50	Cycle the power supply	–

- This parameter is enabled when Switching Mode in Position Control (Pn115) is 3, 5, 6, 9 or 10. It sets the judgment level for switching between Gain 1 and Gain 2. The unit depends on the setting of Switching Mode in Position Control (Pn115).

Pn118	Gain Switching Hysteresis in Position Control						Position
Setting range	0 to 20,000	Unit	–	Default setting	33	Cycle the power supply	–

- Set the hysteresis width above and below the judgment level set in Gain Switching Level in Position Control (Pn117). The unit depends on the setting of Switching Mode in Position Control (Pn115). The definitions of Gain Switching Delay Time in Position Control (Pn116), Gain Switching Level in Position Control (Pn117), and Gain Switching Hysteresis in Position Control (Pn118) are shown in the drawing below.

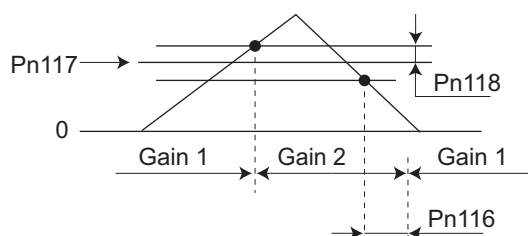

- The settings for Gain Switching Level in Position Control (Pn117) and Gain Switching Hysteresis in Position Control (Pn118) are enabled as absolute values (forward/reverse).

Pn119	Position Gain Switching Time						Position
Setting range	0 to 10,000	Unit	0.1 ms	Default setting	33	Cycle the power supply	–

When using the position control, setting Gain Switching Time helps prevent the rapid increase of the position loop gain if the values set in Position Loop Gain (Pn100) and Position Loop Gain 2 (Pn105) differ significantly. The position loop gain increases as the set time expires.

Position Gain Switching Time

Position Gain Switching Time (Pn119) can be set to mitigate the torque fluctuations and vibration due to a sudden change in the position loop gain when gain is switched. This enables a gradual change in the gain during switching, where the position loop gain gets large, resulting in reduced vibration.



Precautions for Correct Use

- When the position loop gain is switched to a smaller value, gain switching occurs immediately regardless of this parameter setting.
Example: When Position Loop Gain (Pn100) is greater than Position Loop Gain 2 (Pn105)

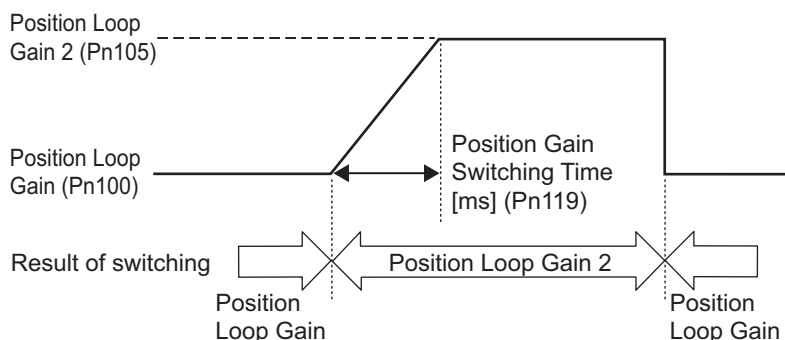

Pn120	Switching Mode in Speed Control						Speed
Setting range	0 to 5	Unit	–	Default setting	0	Cycle the power supply	–

Explanation of Settings

(√: Enabled, –: Disabled)

Set value	Description			
	Gain switching conditions	Gain Switching Delay Time in Speed Control (Pn121) ^{*1}	Gain Switching Level in Speed Control (Pn122)	Gain Switching Hysteresis in Speed Control (Pn123) ^{*2}
0	Always Gain 1 (Pn100 to Pn104).	–	–	–
1	Always Gain 2 (Pn105 to Pn109).	–	–	–
2	Switching using gain switching input (GSEL) (CN1 pin 27)	–	–	–
3	Amount of change in torque command (Refer to Figure A.)	√	√ ^{*3} (0.05%)	√ ^{*3} (0.05%)
4	Amount of change in speed command (Refer to Figure B.)	√	√ ^{*4} [10 r/min/s]	√ ^{*4} [10 r/min/s]
5	Speed command (Refer to Figure C.)	√	√ [r/min]	√ [r/min]

- Select the conditions for switching between Gain 1 and Gain 2 when Gain Switching Input Operating Mode Selection (Pn114) is set to 1.
- This setting is fixed to Gain 1 regardless of the gain input, when Switching Mode in Speed Control (Pn120) is set to 1 and Torque Limit Selection (Pn521) is set to 3 or 6.

*1 Gain Switching Delay Time in Speed Control (Pn121) becomes effective when the gain is switched from 2 to 1.

*2 The definition of Gain Switching Hysteresis in Speed Control (Pn123) is shown in the drawing below.

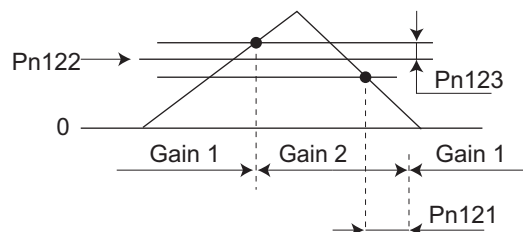

- *3 This represents the amount of change during the period of 1 ms.
Example: To switch the gain if the torque variation during 1 ms is 10%, set these parameters to 200.
- *4 When the set value is 10, the meanings of Gain Switching Delay Time in Speed Control (Pn121), Gain Switching Level in Speed Control (Pn122), and Gain Switching Hysteresis in Speed Control (Pn123) differ from the normal case. (Refer to Figure D.)

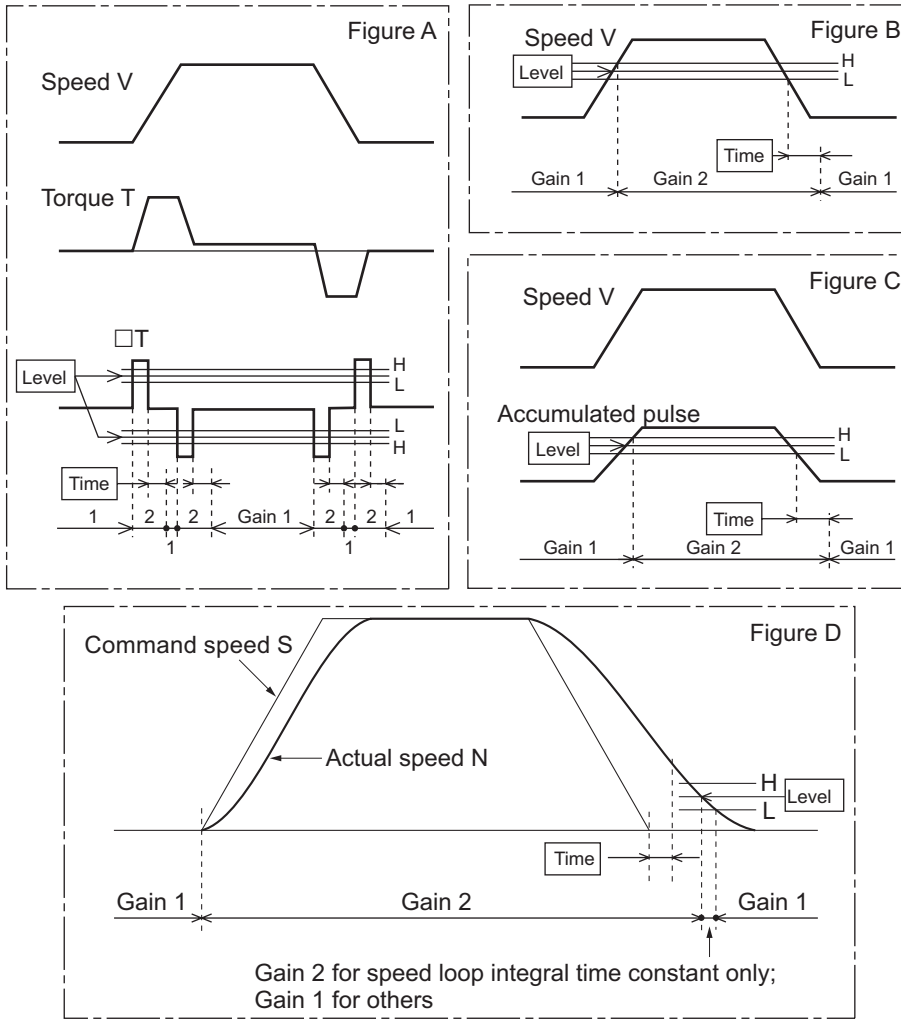

Pn121	Gain Switching Delay Time in Speed Control						Speed
Setting range	0 to 10,000	Unit	0.1 ms	Default setting	0	Cycle the power supply	-

- Set the delay time when returning from Gain 2 to Gain 1 if Switching Mode in Speed Control (Pn120) is set to 3 to 5.

Pn122	Gain Switching Level in Speed Control						Speed
Setting range	0 to 20,000	Unit	-	Default setting	0	Cycle the power supply	-

- This parameter is enabled in the speed control mode when Switching Mode in Speed Control (Pn120) is 3 to 5. It sets the judgment level for switching between Gain 1 and Gain 2. The unit depends on the setting of Switching Mode in Speed Control (Pn120).

Pn123	Gain Switching Hysteresis in Speed Control						Speed
Setting range	0 to 20,000	Unit	–	Default setting	0	Cycle the power supply	–

- Set the hysteresis width above and below the judgment level set in Gain Switching Level in Speed Control (Pn122). The unit depends on the setting of Switching Mode in Speed Control (Pn120). The definitions of Gain Switching Delay Time in Speed Control (Pn121), Gain Switching Level in Speed Control (Pn122), and Gain Switching Hysteresis in Speed Control (Pn123) are shown in the drawing below.

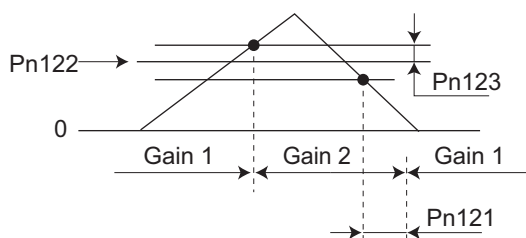

- The settings for Gain Switching Level in Speed Control (Pn122) and Gain Switching Hysteresis in Speed Control (Pn123) are enabled as absolute values (forward/reverse).

Pn124	Reserved						
Setting range	0	Unit	–	Default setting	0	Cycle the power supply	–

- Do not set.

Pn125	Reserved						
Setting range	0	Unit	–	Default setting	0	Cycle the power supply	–

- Do not set.

Pn126	Reserved						
Setting range	0	Unit	–	Default setting	0	Cycle the power supply	–

- Do not set.

Pn127	Reserved						
Setting range	0	Unit	–	Default setting	0	Cycle the power supply	–

- Do not set.

7-3 Vibration Suppression Parameters

Pn200	Adaptive Filter Selection						<input type="text" value="Position"/>	<input type="text" value="Speed"/>
Setting range	0 to 4	Unit	–	Default setting	0	Cycle the power supply	–	

Explanation of Set Values

Set value	Description
0	Disabled. The parameters related to notch filters 3 and 4 hold the current values.
1	One filter enabled. The parameters related to notch filter 3 are updated according to the adaptive result.
2	Two filters enabled. The parameters related to notch filters 3 and 4 are updated according to the adaptive result.
3	Resonance frequency measured. The measurement result can be checked in CX-Drive. The parameters related to notch filters 3 and 4 hold the current values.
4	Adaptive result cleared. The parameters related to notch filters 3 and 4 are disabled and the adaptive result is cleared.

- Set the operation of the adaptive filter.

Pn201	Notch 1 Frequency Setting						<input type="text" value="All"/>
Setting range	50 to 5,000	Unit	Hz	Default setting	5,000	Cycle the power supply	–

- Set the frequency of the first resonance suppression notch filter.
- When set to 5,000, the notch filter function is disabled.

Pn202	Notch 1 Width Setting						<input type="text" value="All"/>
Setting range	0 to 20	Unit	–	Default setting	2	Cycle the power supply	–

- Set the width of the first resonance suppression notch filter in 20 levels.
- Increasing the setting value widens the notch width. Normally, use the default set value.

Pn203	Notch 1 Depth Setting						<input type="text" value="All"/>
Setting range	0 to 99	Unit	–	Default setting	0	Cycle the power supply	–

- Set the notch depth of the first resonance suppression notch filter.
- Increasing the setting value shortens the notch depth and the phase lag.

Pn204	Notch 2 Frequency Setting						<input type="text" value="All"/>
Setting range	50 to 5,000	Unit	Hz	Default setting	5,000	Cycle the power supply	–

- Set the notch frequency of the second resonance suppression notch filter.
- When set to 5,000, the notch filter function is disabled.

Pn205	Notch 2 Width Setting						<input type="button" value="All"/>
Setting range	0 to 20	Unit	–	Default setting	2	Cycle the power supply	–

- Select the notch width of the second resonance suppression notch filter.
- Increasing the setting value widens the notch width. Normally, use the default set value.

Pn206	Notch 2 Depth Setting						<input type="button" value="All"/>
Setting range	0 to 99	Unit	–	Default setting	0	Cycle the power supply	–

- Set the notch depth of the second resonance suppression notch filter.
- Increasing the setting value shortens the notch depth and the phase lag.

Pn207	Notch 3 Frequency Setting						<input type="button" value="All"/>
Setting range	50 to 5,000	Unit	Hz	Default setting	5,000	Cycle the power supply	–

- Set the notch frequency of the third resonance suppression notch filter.
- When set to 5,000, the notch filter function is disabled.

Pn208	Notch 3 Width Setting						<input type="button" value="All"/>
Setting range	0 to 20	Unit	–	Default setting	2	Cycle the power supply	–

- Select the notch width of the third resonance suppression notch filter.
- Increasing the setting value widens the notch width. Normally, use the default set value.

Pn209	Notch 3 Depth Setting						<input type="button" value="All"/>
Setting range	0 to 99	Unit	–	Default setting	0	Cycle the power supply	–

- Set the notch depth of the third resonance suppression notch filter.
- Increasing the setting value shortens the notch depth and the phase lag.

Pn210	Notch 4 Frequency Setting						<input type="button" value="All"/>
Setting range	50 to 5,000	Unit	Hz	Default setting	5,000	Cycle the power supply	–

- Set the notch frequency of the fourth resonance suppression notch filter.
- When set to 5,000, the notch filter function is disabled.

Pn211	Notch 4 Width Setting						<input type="button" value="All"/>
Setting range	0 to 20	Unit	–	Default setting	2	Cycle the power supply	–

- Select the notch width of the fourth resonance suppression notch filter.
- Increasing the setting value widens the notch width. Normally, use the default set value.

Pn212	Notch 4 Depth Setting						<input type="button" value="All"/>
Setting range	0 to 99	Unit	–	Default setting	0	Cycle the power supply	–

- Set the notch depth of the fourth resonance suppression notch filter.
- Increasing the setting value shortens the notch depth and the phase lag.

Pn213	Damping Filter Selection						Position
Setting range	0 to 3	Unit	–	Default setting	0	Cycle the power supply	–

Explanation of Set Values

Set value	Description
0	Damping filters 1 and 2 enabled
1	Either damping filters 1 and 3 or 2 and 4 can be selected via the external input (DFSEL1). <ul style="list-style-type: none"> • When open: Damping filters 1 and 3 enabled • When shorted: Damping filters 2 and 4 enabled
2	Damping filters 1 to 4 can be selected via the external inputs (DFSEL1 and DFSEL2). <ul style="list-style-type: none"> • When DFSEL1 and DFSEL2 are open: Damping filter 1 enabled • When DFSEL1 is shorted and DFSEL2 is open: Damping filter 2 enabled • When DFSEL1 is open and DFSEL2 is shorted: Damping filter 3 enabled • When DFSEL1 and DFSEL2 are shorted: Damping filter 4 enabled
3	The damping filters are switched with position command direction. <ul style="list-style-type: none"> • During forward rotation: Damping filters 1 and 3 enabled • During reverse rotation: Damping filters 2 and 4 enabled

Pn214	Damping Frequency 1						Position
Setting range	0 to 2,000	Unit	0.1 Hz	Default setting	0	Cycle the power supply	–

- Set Damping Frequency 1 to suppress vibration at the end of the load in damping control.
- Measure the frequency of vibration at the end of the load and make the setting in units of 0.1 Hz.
- The range of setting frequency is 1.0 to 200.0 Hz. The function is disabled if the setting is 0 to 0.9 Hz.
- For the setting method, refer also to 6-1 *Damping Control* on page 6-3.

Pn215	Damping Filter 1 Setting						Position
Setting range	0 to 1,000	Unit	0.1 Hz	Default setting	0	Cycle the power supply	–

- When Damping Frequency 1 (Pn214) is set, reduce this value if torque saturation occurs or increase this value to improve the operation speed. Normally, use a setting of 0.
- The value that can be set is limited as follows.
Upper limit: Corresponding damping frequency
Lower limit: Damping frequency + Damping filter setting ≥ 100
- For the setting method, refer also to 6-1 *Damping Control* on page 6-3

Pn216	Damping Frequency 2						Position
Setting range	0 to 2,000	Unit	0.1 Hz	Default setting	0	Cycle the power supply	–

- Set Damping Frequency 2 to suppress vibration at the end of the load in damping control.
- Measure the frequency of vibration at the end of the load and make the setting in units of 0.1 Hz.
- The range of setting frequency is 1.0 to 200.0 Hz. The function is disabled if the setting is 0 to 0.9 Hz.
- For the setting method, refer also to 6-1 *Damping Control* on page 6-3.

Pn217	Damping Filter 2 Setting						Position
Setting range	0 to 1,000	Unit	0.1 Hz	Default setting	0	Cycle the power supply	–

- When Damping Frequency 2 (Pn216) is set, reduce this value if torque saturation occurs or increase this value to improve the operation speed. Normally, use a setting of 0.
- The value that can be set is limited as follows.
Upper limit: Corresponding damping frequency
Lower limit: Damping frequency + Damping filter setting ≥ 100
- For the setting method, refer also to 6-1 *Damping Control* on page 6-3.

Pn218	Damping Frequency 3						Position
Setting range	0 to 2,000	Unit	0.1 Hz	Default setting	0	Cycle the power supply	–

- Set Damping Frequency 3 to suppress vibration at the end of the load in damping control.
- Measure the frequency of vibration at the end of the load and make the setting in units of 0.1 Hz.
- The range of setting frequency is 1.0 to 200.0 Hz. The function is disabled if the setting is 0 to 0.9 Hz.
- For the setting method, refer also to 6-1 *Damping Control* on page 6-3.

Pn219	Damping Filter 3 Setting						Position
Setting range	0 to 1,000	Unit	0.1 Hz	Default setting	0	Cycle the power supply	–

- When Damping Frequency 3 (Pn218) is set, reduce this value if torque saturation occurs or increase this value to improve the operation speed. Normally, use a setting of 0.
- The value that can be set is limited as follows.
Upper limit: Corresponding damping frequency
Lower limit: Damping frequency + Damping filter setting ≥ 100
- For the setting method, refer also to 6-1 *Damping Control* on page 6-3.

Pn220	Damping Frequency 4						Position
Setting range	0 to 2,000	Unit	0.1 Hz	Default setting	0	Cycle the power supply	–

- Set Damping Frequency 4 to suppress vibration at the end of the load in damping control.
- Measure the frequency of vibration at the end of the load and make the setting in units of 0.1 Hz.
- The range of setting frequency is 1.0 to 200.0 Hz. The function is disabled if the setting is 0 to 0.9 Hz.
- For the setting method, refer also to 6-1 *Damping Control* on page 6-3.

Pn221	Damping Filter 4 Setting						Position
Setting range	0 to 1,000	Unit	0.1 Hz	Default setting	0	Cycle the power supply	–

- When Damping Frequency 4 (Pn220) is set, reduce this value if torque saturation occurs or increase this value to improve the operation speed. Normally, use a setting of 0.
- The value that can be set is limited as follows.
Upper limit: Corresponding damping frequency
Lower limit: Damping frequency + Damping filter setting ≥ 100
- For the setting method, refer also to 6-1 *Damping Control* on page 6-3.

Pn222	Position Command Filter Time Constant						Position
Setting range	0 to 10,000	Unit	0.1 ms	Default setting	0	Cycle the power supply	-

- Position Command Filter Time Constant is the first-order lag filter that is inserted after the electronic gear ratio for the command pulse input.
- Purposes of Position Command Filter Time Constant:
 - This parameter is used basically for reducing the stepwise movement of the Servomotor with sparse command pulse input
 - Specifically, sparse command pulse input may occur in the following cases:
The electronic gear ratio is set to a large value (10 or higher).
The command pulse frequency is low.

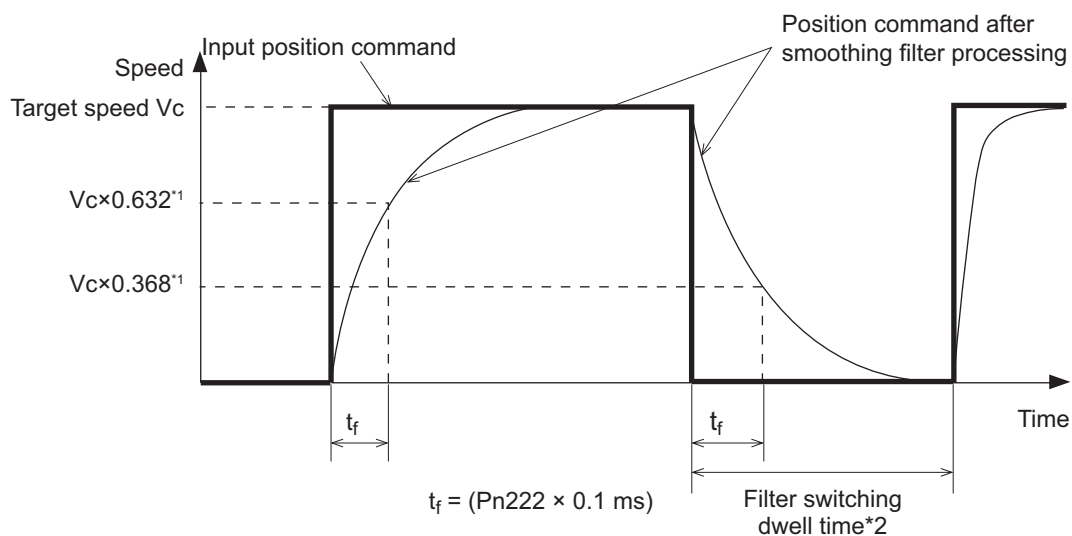

*1 The actual processing speed is subject to calculation error.
 *2 The Servomotor may operate at a higher speed than the original command speed immediately after filter switching operation, if accumulated pulses remain in the filter after a change in the filter value.

Pn223	Smoothing Filter Time Constant					Position	
Setting range	0 to 10,000	Unit	0.1 ms	Default setting	0	Cycle the power supply	–

- Set the time constant for the FIR filter applied to the command pulses. (FIR: Finite Impulse Response)
- Setting a larger value improves the smoothness of the command pulse input.

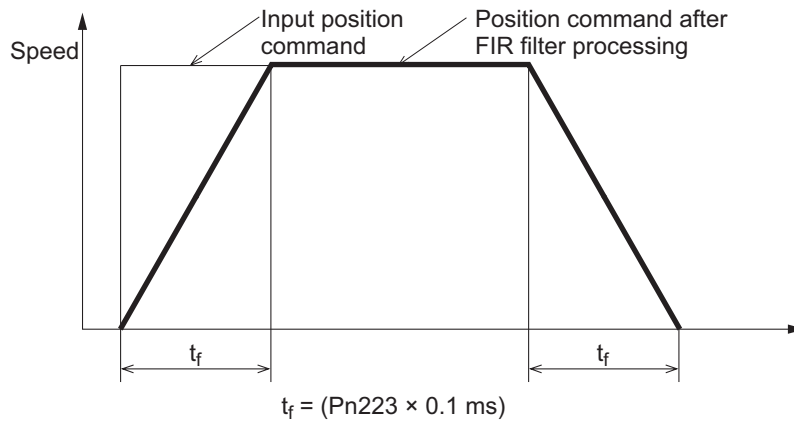

7-4 Analog Control Parameters

Pn300	Command Speed Selection						Speed
Setting range	1 to 3	Unit	–	Default setting	1	Cycle the power supply	–

Explanation of Set Values

Set value	Description
0	Reserved (Do not set.)
1	No. 1 Internally Set Speed to No. 4 Internally Set Speed (Pn304 to Pn307)
2	Reserved (Do not set.)
3	No. 1 Internally Set Speed to No. 8 Internally Set Speed (Pn304 to Pn311)

- Select the speed command in the speed control mode. The Servo Drive has the internally set speed function that enables simplified speed control via contact inputs.

Pn301	Speed Command Direction Selection						Speed
Setting range	0 to 1	Unit	–	Default setting	0	Cycle the power supply	–

Explanation of Set Values

Set value	Description
0	Use the sign of the speed command (+: Forward, -: Reverse)
1	Use Speed Command Sign Input (VSIGN) (OFF: Forward, ON: Reverse)

- This parameter reverses the polarity of the internally set speed command. It is used to change the motor rotation direction with the polarity of the command signal from the host system intact.
- The default setting for this parameter is 0. By rotating to the reverse direction with the +command keeps the compatibility with all OMNUC W-Series Servo Drives.
- If you configure a servo drive system which comprises a Servo Drive set to the speed control mode and an external Position Control Unit, be sure that the polarity of the speed command signal from the Position Control Unit matches the polarity set in this parameter. Otherwise, the Servomotor may operate abnormally.

Speed Command Direction Selection (Pn301)	Internally set speed	Speed Command Sign Input (VSIGN)	Servomotor rotation direction
0	0 to 20,000	No effect	Forward direction
	–20,000 to 0	No effect	Reverse direction
1	0 to 20,000	OFF	Forward direction
	–2,000 to 0		
	0 to 20,000	ON	Reverse direction
	–20,000 to 0		

Pn302	Reserved						
Setting range	500	Unit	–	Default setting	500	Cycle the power supply	–

- Do not set.

Pn303	Reserved						
Setting range	1	Unit	–	Default setting	1	Cycle the power supply	–

- Do not set.

Pn304	No. 1 Internally Set Speed						Speed
Setting range	–20,000 to 20,000	Unit	r/min	Default setting	0	Cycle the power supply	–

Pn305	No. 2 Internally Set Speed						Speed
Setting range	–20,000 to 20,000	Unit	r/min	Default setting	0	Cycle the power supply	–

Pn306	No. 3 Internally Set Speed						Speed
Setting range	–20,000 to 20,000	Unit	r/min	Default setting	0	Cycle the power supply	–

Pn307	No. 4 Internally Set Speed						Speed
Setting range	–20,000 to 20,000	Unit	r/min	Default setting	0	Cycle the power supply	–

Pn308	No. 5 Internally Set Speed						Speed
Setting range	–20,000 to 20,000	Unit	r/min	Default setting	0	Cycle the power supply	–

Pn309	No. 6 Internally Set Speed						Speed
Setting range	–20,000 to 20,000	Unit	r/min	Default setting	0	Cycle the power supply	–

Pn310	No. 7 Internally Set Speed						Speed
Setting range	–20,000 to 20,000	Unit	r/min	Default setting	0	Cycle the power supply	–

Pn311	No. 8 Internally Set Speed						Speed
Setting range	-20,000 to 20,000	Unit	r/min	Default setting	0	Cycle the power supply	-

- If you enabled a range of Internally Set Speed settings in Command Speed Selection (Pn300), set in units of r/min the first to fourth internally set speeds in Pn304 to Pn307 or the fifth to eighth internally set speeds in Pn308 to Pn311.
- The +/- sign prefixed to the set value indicates the polarity of the internally set speed command.

+	Forward when viewed from shaft end
-	Reverse when viewed from shaft end

- The absolute value of this parameter setting is limited by the value set in Overspeed Detection Level Setting (Pn513).

Pn312	Soft Start Acceleration Time						Speed
Setting range	0 to 10,000	Unit	ms/(1,000 r/min)	Default setting	0	Cycle the power supply	-

Pn313	Soft Start Deceleration Time						Speed
Setting range	0 to 10,000	Unit	ms/(1,000 r/min)	Default setting	0	Cycle the power supply	-

- Set the acceleration/deceleration speed applied inside the Servo Drive to control the motor speed.
- The soft start function can be used with stepwise speed command input or internal speed settings.
- If the Servo Drive is used in combination with an external position loop, do not set these acceleration and deceleration time parameters. (Set both Pn312 and Pn313 to 0.)

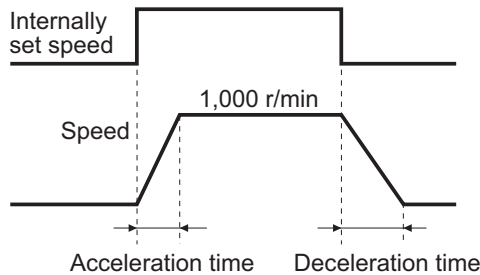

Pn314	S-curve Acceleration/Deceleration Time Setting						Speed
Setting range	0 to 1,000	Unit	ms	Default setting	0	Cycle the power supply	-

- Set the pseudo S-curve acceleration/deceleration value to add to the speed command to enable smooth operation. This is useful for applications where impact may occur due to a large change in acceleration or deceleration when the Servomotor starts or stops with linear acceleration or deceleration.

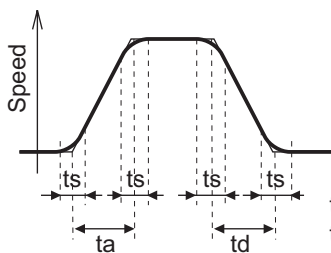

1. Set the acceleration time and the deceleration time for the basic straight-line portion in Pn312 and Pn313.
2. Set the acceleration/deceleration time (in units of 2 ms) for the S-curve portion in Pn314 as the duration centered at the inflection point of the linear acceleration/deceleration.

ta: Pn312
td: Pn313
ts: Pn314

Use the following settings.

$$\frac{td}{2} > ts, \text{ and } \frac{ta}{2} > ts.$$

Pn315	Zero Speed Designation Selection						Speed
Setting range	0 to 3	Unit	–	Default setting	0	Cycle the power supply	–

Explanation of Set Values

Set value	Description
0	The Zero Speed Designation Input function is disabled.
1	The speed command is 0 when Zero Speed Designation is input. (Refer to Figure A.)
2	The speed command is 0 when Zero Speed Designation is input. The Servomotor falls in a servo lock state in the position control if the actual speed reaches the setting value or less in Position Lock Level Setting (Pn316). (Refer to Figure B.)
3	When the Zero Speed Designation is input, the Servomotor falls in a servo lock state in the position control if the actual speed reaches the setting value or less in Position Lock Level Setting (Pn316). (Refer to Figure C.)

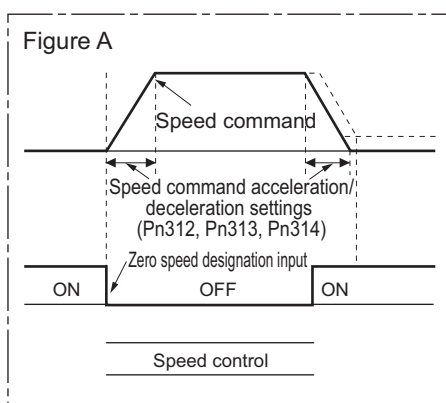

- When the zero speed designation input is ON, the speed command is forcibly set to 0.
- Set the acceleration and deceleration time settings for the speed command in Soft Start Acceleration Time (Pn312), Soft Start Deceleration Time (Pn313), and S-curve Acceleration/Deceleration Time Setting (Pn314).

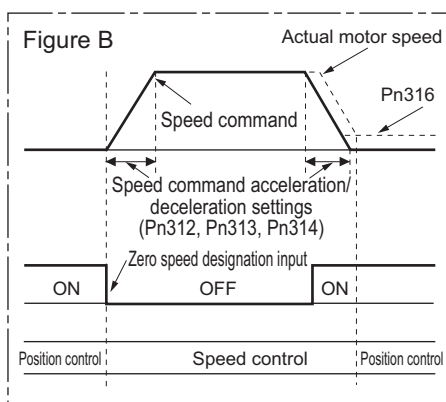

- When the zero speed designation input is turned ON, if the speed command is equal to or less than the Position Lock Level Setting (Pn316) minus 10 r/min, the control mode switches to position control and the servo is locked. If the speed command becomes equal to or greater than the Position Lock Level Setting (Pn316) plus 10 r/min, the control mode switches from position to speed control and the motor rotates at the command speed.
- In the position control mode, the position command is forcibly set to 0. Be sure to set the position loop gain, alarm detection, and other function settings appropriately.
- Use this parameter when Control Mode Selection (Pn001) is set to 1 (speed control). It may not function properly when Control Mode Selection (Pn001) is set to 3 (position/speed control).

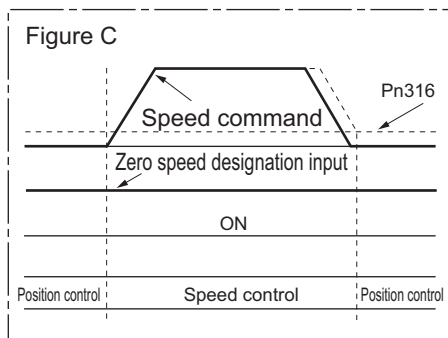

- When the zero speed designation input is turned ON, if the speed command is equal to or less than the Position Lock Level Setting (Pn316), the control mode switches to position control and the servo is locked.
- When the zero speed designation input is ON, the speed command must be changed because it is never 0.
- In the position control mode, the position command provides normal position control. Be sure to set the position loop gain, alarm detection, and other function settings appropriately.
- Use this parameter when Control Mode Selection (Pn001) is set to 1 (speed control). It may not function properly when Control Mode Selection (Pn001) is set to 3 (position/speed control).

Pn316	Position Lock Level Setting						Speed
Setting range	10 to 20,000	Unit	r/min	Default setting	30	Cycle the power supply	–

- The Servomotor falls in a servo lock state in the position control mode if the actual motor speed reaches the value set in this parameter or less.
- The set value of this parameter is valid in both forward and reverse directions, regardless of the actual motor rotation direction.

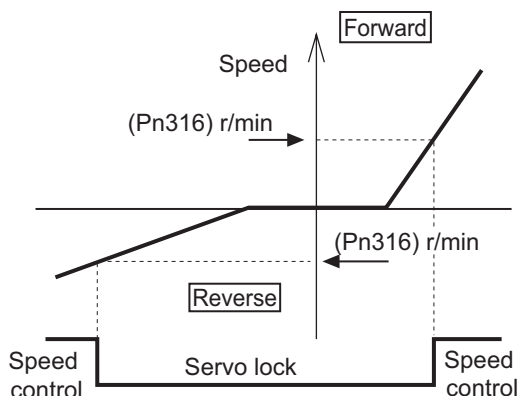

Pn317	Reserved						
Setting range	0	Unit	–	Default setting	0	Cycle the power supply	–

- Do not set.

Pn318	Reserved						
Setting range	0	Unit	–	Default setting	0	Cycle the power supply	–

- Do not set.

Pn319	Reserved						
Setting range	30	Unit	–	Default setting	30	Cycle the power supply	–

- Do not set.

Pn320	Reserved						
Setting range	0	Unit	–	Default setting	0	Cycle the power supply	–

- Do not set.

Pn321	Reserved						
Setting range	0	Unit	–	Default setting	0	Cycle the power supply	–

- Do not set.

Pn322	Reserved						
Setting range	0	Unit	–	Default setting	0	Cycle the power supply	–

- Do not set.

Pn323	Reserved						
Setting range	0	Unit	–	Default setting	0	Cycle the power supply	–

- Do not set.

Pn324	Reserved						
Setting range	0	Unit	–	Default setting	0	Cycle the power supply	–

- Do not set.

Pn325	Reserved						
Setting range	10,000	Unit	–	Default setting	10,000	Cycle the power supply	–

- Do not set.

Pn326	Reserved						
Setting range	0	Unit	–	Default setting	0	Cycle the power supply	–

- Do not set.

Pn327	Reserved						
Setting range	0	Unit	–	Default setting	0	Cycle the power supply	–

- Do not set.

Pn328	Reserved						
Setting range	16,000	Unit	–	Default setting	16,000	Cycle the power supply	–

- Do not set.

Pn329	Reserved						
Setting range	0	Unit	–	Default setting	0	Cycle the power supply	–

- Do not set.

7-5 Interface Monitor Setting Parameters

Pn400	Input Signal Selection 1						All
Setting range	0 to 00FFFFFF hex	Unit	–	Default setting	8,553,090	Cycle the power supply	Required
Pn401	Input Signal Selection 2						All
Setting range	0 to 00FFFFFF hex	Unit	–	Default setting	8,487,297	Cycle the power supply	Required
Pn402	Input Signal Selection 3						All
Setting range	0 to 00FFFFFF hex	Unit	–	Default setting	9,539,850	Cycle the power supply	Required
Pn403	Input Signal Selection 4						All
Setting range	0 to 00FFFFFF hex	Unit	–	Default setting	394,758	Cycle the power supply	Required
Pn404	Input Signal Selection 5						All
Setting range	0 to 00FFFFFF hex	Unit	–	Default setting	4,108	Cycle the power supply	Required
Pn405	Input Signal Selection 6						All
Setting range	0 to 00FFFFFF hex	Unit	–	Default setting	197,379	Cycle the power supply	Required
Pn406	Input Signal Selection 7						All
Setting range	0 to 00FFFFFF hex	Unit	–	Default setting	3,847	Cycle the power supply	Required
Pn407	Input Signal Selection 8						All
Setting range	0 to 00FFFFFF hex	Unit	–	Default setting	263,172	Cycle the power supply	Required
Pn408	Input Signal Selection 9						All
Setting range	0 to 00FFFFFF hex	Unit	–	Default setting	328,965	Cycle the power supply	Required
Pn409	Input Signal Selection 10						All
Setting range	0 to 00FFFFFF hex	Unit	–	Default setting	3,720	Cycle the power supply	Required
Pn410	Output Signal Selection 1						All
Setting range	0 to 00FFFFFF hex	Unit	–	Default setting	197,379	Cycle the power supply	Required

Pn411	Output Signal Selection 2						All
Setting range	0 to 00FFFFFF hex	Unit	–	Default setting	131,586	Cycle the power supply	Required

Pn412	Not used						All
Setting range	–	Unit	–	Default setting	–	Cycle the power supply	–

Pn413	Output Signal Selection 4						All
Setting range	0 to 00FFFFFF hex	Unit	–	Default setting	328,964	Cycle the power supply	Required

- For the setting method, refer also to 6-9 *Sequence I/O Signals* on page 6-33.

Pn416	Analog Monitor 1 Selection						All
Setting range	0 to 21	Unit	–	Default setting	0	Cycle the power supply	–

Explanation of Set Values

Set value	Description		
	Monitor type	Unit	Output gain when Pn417 = 0
0	Motor speed	r/min	500
1	Position command speed ^{*2}	r/min	500
2	Internal position command speed ^{*2}	r/min	500
3	Speed control command	r/min	500
4	Torque command	% (Rated torque ratio)	33
5	Position command error ^{*3}	–	3,000
6	Encoder position error ^{*3}	Pulses (encoder units)	3,000
7	Reserved (Do not set.)	–	3,000
8	Reserved (Do not set.)	–	3,000
9	P-N voltage	V	80
10	Regeneration load ratio	%	33
11	Overload load ratio	%	33
12	Forward direction torque limit	% (Rated torque ratio)	33
13	Reverse direction torque limit	% (Rated torque ratio)	33
14	Speed limit value	r/min	500
15	Inertia ratio	%	500
16	Reserved (Do not set.)	–	1
17	Reserved (Do not set.)	–	1
18	Reserved (Do not set.)	–	1

Set value	Description		
	Monitor type	Unit	Output gain when Pn417 = 0
19	Encoder temperature	–	–
20	Drive temperature	°C	10
21	Encoder 1-rotation data*1	Pulses (encoder units)	110,000

- *1 The forward or reverse direction in monitor data depends on the direction set in Pn000. For an incremental encoder, the normal value after the initial phase-Z input will be output.
- *2 The motor speed applied before and after the command pulse input passes through the command filter (Position Command Filter Time Constant or Smoothing Filter Time Constant) is referred to as “command pulse speed” or “internal command speed.”
- *3 The position command error is a deviation from the command pulse input, while the encoder position error is a deviation at the input of the Position Control Unit.

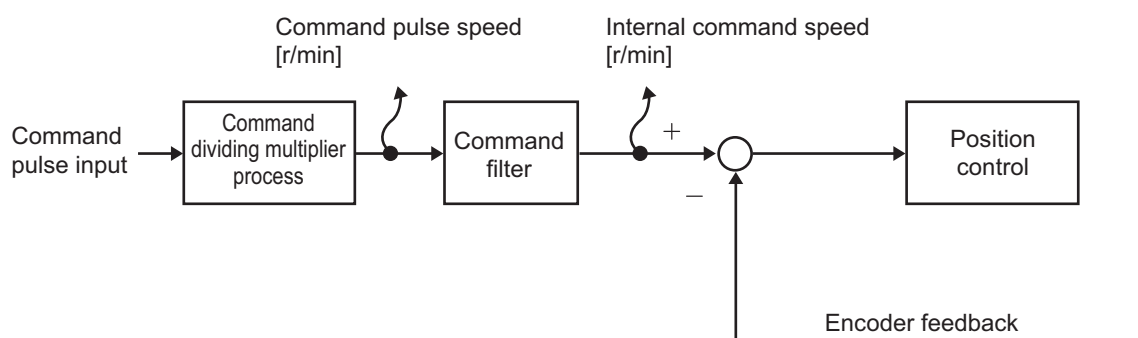

- *4 The position error/feedback pulse error can be set in either encoder units or command units. It represents a deviation from the command pulse input when expressed in encoder units and a deviation from the command pulse input when expressed in command units, respectively.

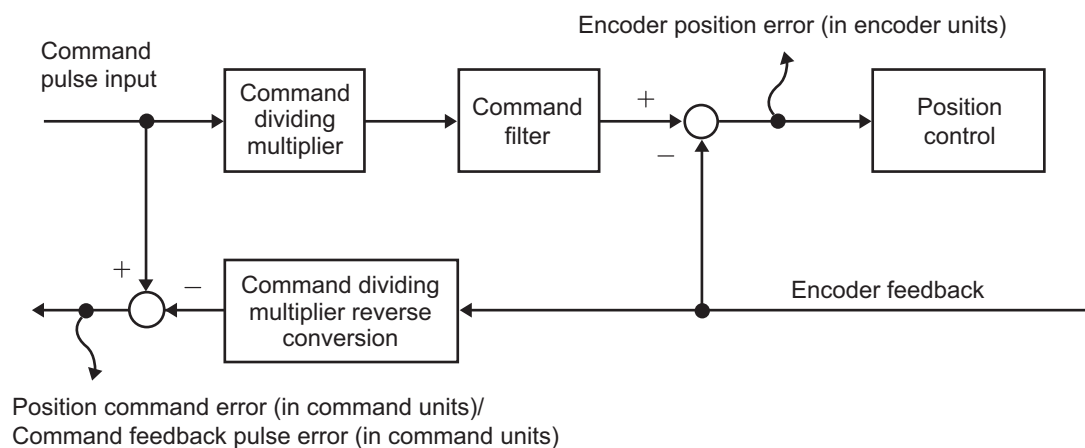

Pn417	Analog Monitor 1 Scale Setting						All
Setting range	0 to 214,748,364	Unit	Pn416 monitor unit/V	Default setting	0	Cycle the power supply	–

- Set the output gain of the analog monitor 1.

Pn418	Analog Monitor 2 Selection						All
Setting range	0 to 21	Unit	–	Default setting	4	Cycle the power supply	–

- Select the type of analog monitor 2.
- The set values for this parameter are the same as those of Analog Monitor 1 Selection (Pn416).

Pn419	Analog Monitor 2 Scale Setting						All
Setting range	0 to 214,748,364	Unit	Pn418 monitor unit/V	Default setting	0	Cycle the power supply	–

- Set the output gain of the analog monitor 2.

Pn421	Analog Monitor Output Setting						All
Setting range	0 to 2	Unit	–	Default setting	0	Cycle the power supply	–

- Select the analog monitor output voltage direction.

Set value	Output range	Data output
0	–10 to 10 V	
1	0 to 10 V	
2	0 to 10 V	

- An example when the monitor type is Motor speed and the conversion gain is 500 (1 V = 500 r/min)

Pn422	Reserved						All
Setting range	0	Unit	–	Default setting	0	Cycle the power supply	–

- Do not set.

Pn423	Reserved						All
Setting range	0	Unit	–	Default setting	0	Cycle the power supply	–

- Do not set.

Pn424	Reserved						
Setting range	0	Unit	–	Default setting	0	Cycle the power supply	–

- Do not set.

Pn425	Reserved						
Setting range	0	Unit	–	Default setting	0	Cycle the power supply	–

- Do not set.

Pn426	Reserved						
Setting range	0	Unit	–	Default setting	0	Cycle the power supply	–

- Do not set.

Pn427	Reserved						
Setting range	0	Unit	–	Default setting	0	Cycle the power supply	–

- Do not set.

Pn428	Reserved						
Setting range	0	Unit	–	Default setting	0	Cycle the power supply	–

- Do not set.

Pn429	Reserved						
Setting range	0	Unit	–	Default setting	0	Cycle the power supply	–

- Do not set.

Pn430	Reserved						
Setting range	0	Unit	–	Default setting	0	Cycle the power supply	–

- Do not set.

Pn431	Positioning Completion Range 1						Position
Setting range	0 to 262,144	Unit	Command units	Default setting	10	Cycle the power supply	–

- Use this parameter in combination with Positioning Completion Condition Selection (Pn432) to set the output timing of the positioning completion output. The positioning completion output (INP) will be output if, after command pulse input, the Servomotor (workpiece) completes its movement and the number of pulses in the error counter falls within the range defined as “±(set value).”
- Although the setting unit is command units, you can change it to encoder units in Position Setting Unit Selection (Pn520). However, note that the unit for error counter overflow level is changed as well.
- If the parameter value is set too small, the time until the INP signal is output may increase or chattering may appear in the output signal. Positioning Completion Range settings do not affect on the final positioning accuracy.

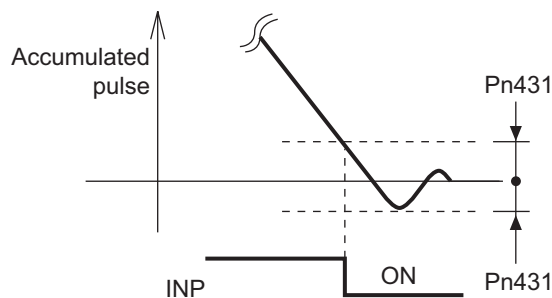

Pn432	Positioning Completion Condition Selection						Position
Setting range	0 to 3	Unit	–	Default setting	0	Cycle the power supply	–

Explanation of Set Values

Set value	Description
0	The positioning completion output turns ON when the position error is equal to or less than Positioning Completion Range 1 (Pn431).
1	The positioning completion output turns ON when there is no position command and the position error is equal to or less than Positioning Completion Range 1 (Pn431).
2	The positioning completion output turns ON when there is no position command, the zero speed detection signal is ON, and the position error is equal to or less than Positioning Completion Range 1 (Pn431).
3	The positioning completion output turns ON when there is no position command and the position error is equal to or less than Positioning Completion Range 1 (Pn431). Then, the ON status is held until the time set in Positioning Completion Hold Time (Pn433) expires and, after that, the ON/OFF status is determined according to the position error status.

- Use this parameter in combination with Positioning Completion Range 1 (Pn431) to set the behavior of the positioning completion output (INP: CN1 pin 39).

Pn433	Positioning Completion Hold Time						Position
Setting range	0 to 30,000	Unit	1 ms	Default setting	0	Cycle the power supply	–

- The positioning completion hold time is infinite when Pn433 is set to 0 and the ON status will be held until the next position command is input.

Pn434	Zero Speed Detection						All
Setting range	10 to 20,000	Unit	r/min	Default setting	50	Cycle the power supply	-

- Set the general-purpose output timing as rotation speed [r/min].
- The general-purpose output 1 (ZSP) turns ON when the motor speed is lower than the set value of this parameter.
- The set value of this parameter is valid in both forward and reverse directions, regardless of the actual motor rotation direction. This setting has a hysteresis of 10 r/min.

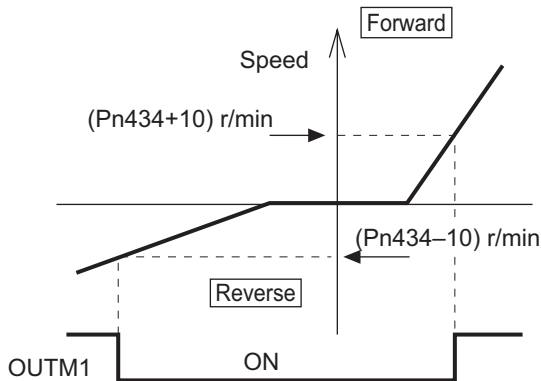

Pn435	Speed Conformity Detection Range						Speed
Setting range	10 to 20,000	Unit	r/min	Default setting	50	Cycle the power supply	-

- The Speed Conformity Output signal will output if the speed command value matches the motor speed.
- This setting has a hysteresis of 10 r/min for detection.

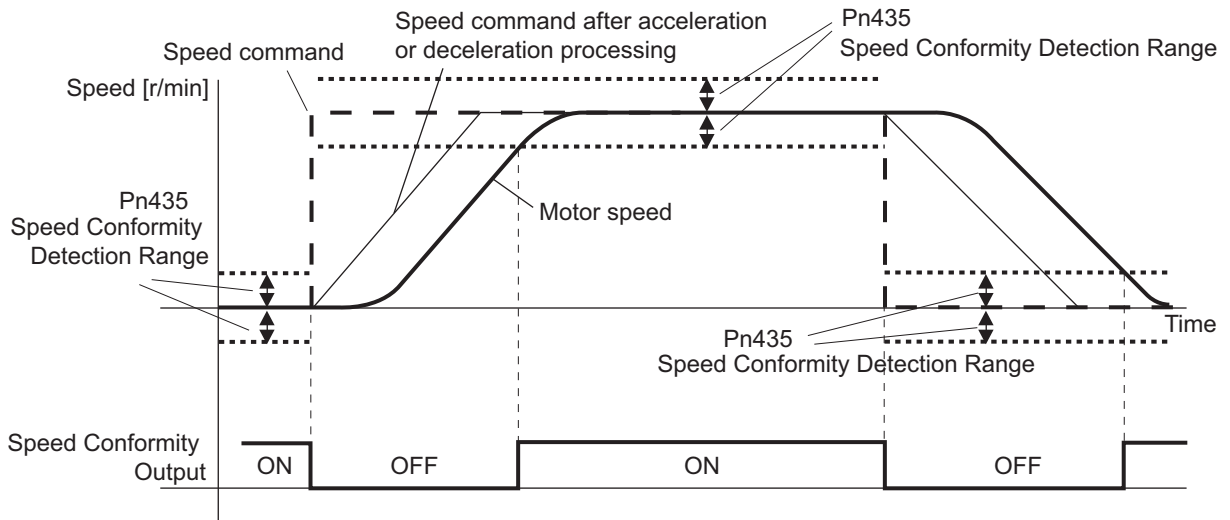

Pn436	Rotation Speed for Motor Rotation Detection						Speed
Setting range	10 to 20,000	Unit	r/min	Default setting	1,000	Cycle the power supply	-

- Motor rotation speed detection output signal is output when the motor speed reaches the speed set as the achieved speed.
- This setting has a hysteresis of 10 r/min for detection.

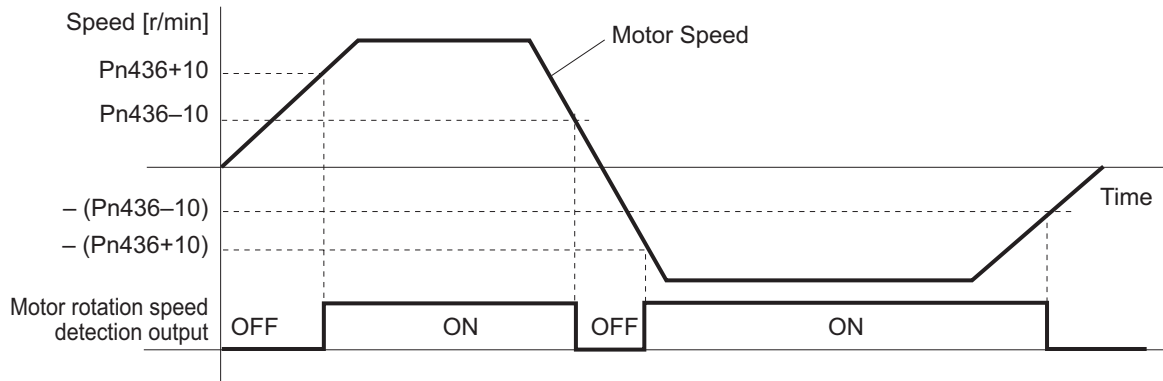

Pn437	Brake Timing when Stopped						Speed
Setting range	0 to 10,000	Unit	1 ms	Default setting	0	Cycle the power supply	-

- Set the time required for the Servomotor to be de-energized (servo free) after the Brake Interlock Output (BKIR: CN1 pin 10) turns OFF (i.e., brake held), when servo OFF status is entered while the Servomotor is stopped.
- When the Operation Command (RUN) turns OFF while the Servomotor is stopped, the Brake Interlock Output (BKIR) turns OFF, and the Servomotor is de-energized after waiting for the set time (set value x ms).

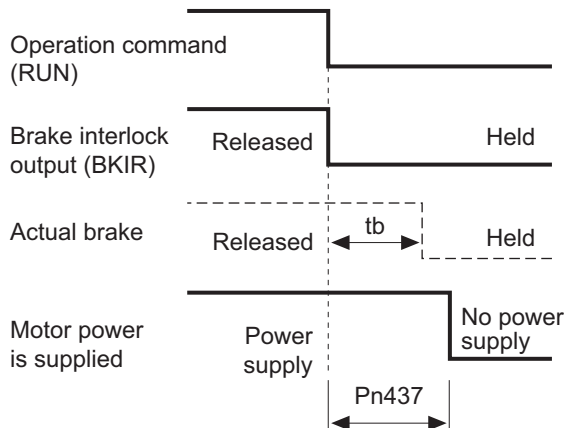

Make the setting as follows to prevent the machine (workpiece) from moving or falling due to the delay time in the brake operation (tb).

$$\text{Brake Timing when Stopped (set value} \times 1 \text{ ms)} \geq tb$$

- For details, refer to 6-6 Brake Interlock on page 6-18.

Pn438	Brake Timing during Operation						All
Setting range	0 to 10,000	Unit	1 ms	Default setting	0	Cycle the power supply	-

- Set the time required for the Brake Interlock Output (BKIR: CN1 pin 10) to turn OFF after the Operation Command (RUN: CN1 pin 29) is detected to be OFF, when servo OFF status is entered while the Servomotor is operating.
When the Operation Command (RUN) turns OFF while the Servomotor is operating, the motor decelerates to reduce rotation speed, and the Brake Interlock Output (BKIR) turns ON after the set time (set value x 1 ms) elapsed.

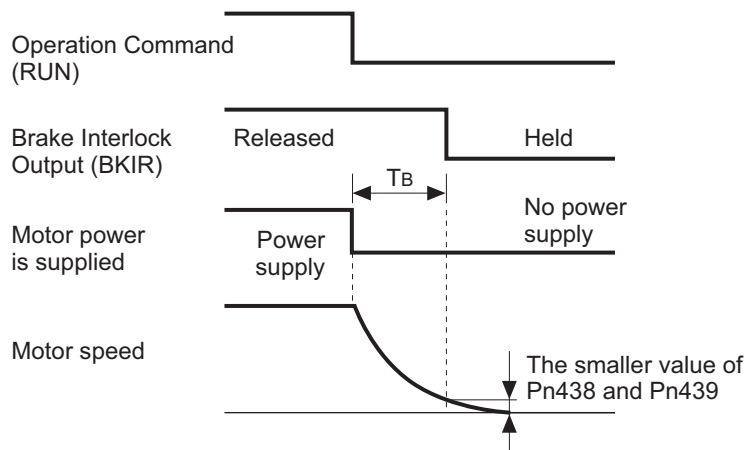

“TB” in the above figure is the setting time in Brake Timing During Operation (Pn438) (set value x 1 ms) or the time until the motor rotation speed falls to the setting speed or lower in Brake Release Speed Setting (Pn439), whichever is shorter.

- For details, refer to 6-6 Brake Interlock on page 6-18.

Pn439	Brake Release Speed Setting						All
Setting range	30 to 3,000	Unit	r/min	Default setting	30	Cycle the power supply	-

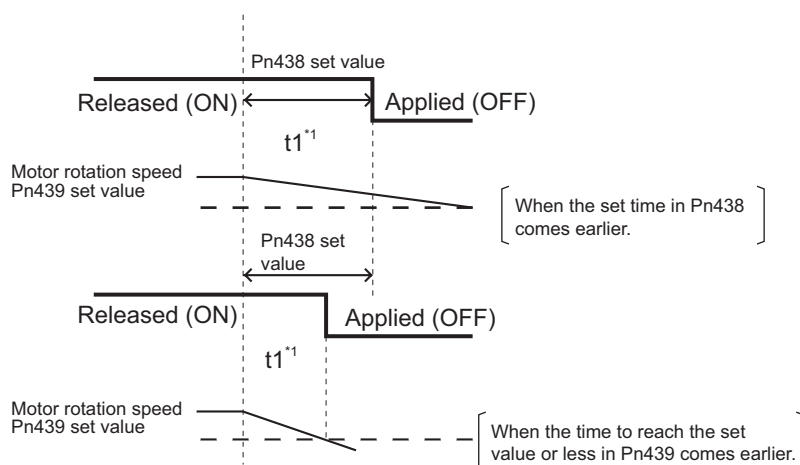

Pn440	Warning Output Selection 1						All
Setting range	0 to 10	Unit	-	Default setting	0	Cycle the power supply	-

Explanation of Set Values

Set value	Description
0	OR output for all types of warnings
1	Overload warning
2	Excessive regeneration warning
3	Battery warning
4	Fan warning
5	Encoder communications warning
6	Encoder overheating warning
7	Vibration detection warning
8	Service life detection warning
9	Reserved (Do not set.)
10	Reserved (Do not set.)

- For the setting method, refer also to 10-2 Warning List on page 10-5.

Pn441	Warning Output Selection 2						All
Setting range	0 to 10	Unit	-	Default setting	0	Cycle the power supply	-

- For this parameter, set the same value as for Warning Output Selection 1 (Pn440).

Pn442	Positioning Completion Range 2						Position
Setting range	0 to 262,144	Unit	Command units	Default setting	10	Cycle the power supply	-

- Set the positioning completion range.
- For this parameter, set the same value as for Positioning Completion Range 1 (Pn431).

7-6 Extended Parameters

Pn500	Electronic Gear Ratio Numerator 2						Position
Setting range	0 to 2 ³⁰	Unit	–	Default setting	0	Cycle the power supply	–
Pn501	Electronic Gear Ratio Numerator 3						Position
Setting range	0 to 2 ³⁰	Unit	–	Default setting	0	Cycle the power supply	–
Pn502	Electronic Gear Ratio Numerator 4						Position
Setting range	0 to 2 ³⁰	Unit	–	Default setting	0	Cycle the power supply	–
Pn503	Encoder Dividing Denominator						All
Setting range	0 to 262,144	Unit	–	Default setting	0	Cycle the power supply	Required

- Encoder pulses are divided based on the following formula if Encoder Dividing Denominator is not 0.

$$\text{Encoder feedback pulse} \rightarrow \frac{\text{Pn011}}{\text{Pn503}} \rightarrow \text{Output pulse}$$

Therefore, if the host system generated a pulse count in the quadruple process, the resolution of pulse output per rotation can be calculated using the following formula.

$$\text{Resolution of pulse output per rotation} = \frac{\text{Pn011}}{\text{Pn503}} \times \text{Encoder resolution}$$

- The resolution of pulse output per rotation is not more than the encoder resolution. (With the above settings, the resolution of pulse output per rotation is equal to the encoder resolution.)
- For the phase-Z signal, one pulse will be output per motor rotation.
- The phase-Z signal will be output in sync with the phase-A signal when the resolution of pulse output per rotation calculated using the above formula is a multiple of 4. In other cases, however, the phase-Z signal will not be synchronized with the phase-A signal because it is output at the encoder resolution and its width is narrower than the phase-A signal.

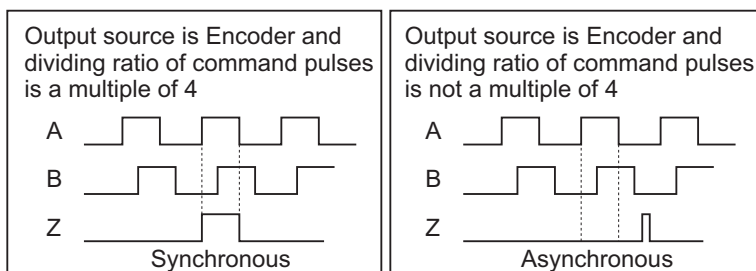

Pn504	Drive Prohibition Input Selection						All
Setting range	0 to 2	Unit	–	Default setting	1	Cycle the power supply	Required

Explanation of Set Values

Set value	Description
0	Forward/Reverse Drive Prohibition Input enabled
1	Forward/Reverse Drive Prohibition Input disabled
2	Forward/Reverse Drive Prohibition Input enabled

- Install a limit switch at each end of the motor shaft to prohibit the Servomotor from being driven in the direction corresponding to the switch that has been activated, thus preventing damage to the machine due to a workpiece overrun.
- The function operates as follows when this parameter is set to 0:
 - When Forward Drive Prohibition Input (POT: CN1 pin 9) and COM are connected: Normal state in which the forward limit switch is not operating
 - When Forward Drive Prohibition Input (POT: CN1 pin 9) and COM are open: Forward rotation prohibited and reverse rotation permitted
 - When Reverse Drive Prohibition Input (NOT: CN1 pin 8) and COM are connected: Normal state in which the reverse limit switch is not operating
 - When Reverse Drive Prohibition Input (NOT: CN1 pin 8) and COM are open: Reverse rotation prohibited and forward rotation permitted
- When set to 0, the Servomotor decelerates and stops according to the sequence set in Stop Selection for Drive Prohibition Input (Pn505). For details, refer to explanation for Stop Selection for Drive Prohibition Input (Pn505).
- When set to 0 and if both the Forward and Reverse Prohibition Input signals are open, a Drive Prohibition Input Error (Alarm No. 38) will occur.
- When set to 2, a Drive Prohibition Input Error (Alarm No. 38) will occur when the connection between either Forward or Reverse Prohibition Input and COM is open.
- If a limit switch above the workpiece is turned OFF when using a vertical axis, the upward torque decreases, and there may be repeated vertical movement of the workpiece. If this occurs, set Stop Selection for Drive Prohibition Input (Pn505) to 2, or limit the operation using the host controller instead of using this function.

Pn505	Stop Selection for Drive Prohibition Input						All
Setting range	0 to 2	Unit	–	Default setting	0	Cycle the power supply	Required

Explanation of Set Values

Set value	Description
0	During deceleration: Dynamic brake operation After stopping: Torque command = 0 for drive prohibition direction Error counter: Hold
1	During deceleration: Torque command = 0 for drive prohibition direction After stopping: Torque command = 0 for drive prohibition direction Error counter: Hold
2	During deceleration: Immediate stop After stopping: Torque command = 0 for drive prohibition direction Error counter: Clear before and after deceleration

- Set the drive conditions during deceleration and after stopping, when the Forward Prohibition Input (POT: CN1 pin 9) or Reverse Drive Prohibition Input (NOT: CN1 pin 8) is enabled.
- When set to 2, the torque limit during deceleration is limited by the value set in Immediate Stop Torque (Pn511).
- The dynamic brake is designed only for immediate stop. Configure the system to stop for about three minutes after the dynamic brake operates.

Pn506	Stop Selection with Servo OFF						All
Setting range	0 to 9	Unit	–	Default setting	0	Cycle the power supply	–

Explanation of Set Values

Set value	Description		
	During deceleration ^{*3}	After stopping	Error counter
0	Dynamic brake operation	Dynamic brake operation	Clear ^{*4}
1	Free-run	Dynamic brake operation	Clear ^{*4}
2	Dynamic brake operation	Servo-free	Clear ^{*4}
3	Free-run	Servo-free	Clear ^{*4}
4	Dynamic brake operation	Dynamic brake operation	Hold ^{*2}
5	Free-run	Dynamic brake operation	Hold ^{*2}
6	Dynamic brake operation	Servo-free	Hold ^{*2}
7	Free-run	Servo-free	Hold ^{*2}
8	Immediate stop ^{*1}	Dynamic brake operation	Clear ^{*4}
9	Immediate stop ^{*1}	Servo-free	Clear ^{*4}

- If an alarm occurs with the servo OFF, the Servomotor will operate according to the value set in Stop Selection for Alarm Detection (Pn510). If the main power supply is turned OFF with the servo OFF, the Servomotor will operate according to the value set in Stop Selection with Main Power Supply OFF (Pn507).
- The dynamic brake is designed only for immediate stop. Configure the system to stop for about three minutes after the dynamic brake operates.

*1 “Immediate stop” means stopping the Servomotor immediately by using control with the servo ON. The torque command value at this time is limited by the value set in Immediate Stop Torque (Pn511).

*2 If the position command is supplied continuously or if the Servomotor rotates continuously with the servo OFF, a Error Counter Overflow (Alarm No. 24.0) may occur due to the accumulation of position errors. In addition, if the servo turns ON with a large position error, the Servomotor may start moving suddenly because the control attempts to zero the error. Take extra care when using the Servo Drive with this parameter set to hold the position error counter content.

*3 “During deceleration” means the period until the motor decreases its speed to 30 r/min or less from the normal operation. Once the Servomotor decelerates to 30 r/min or lower and falls in an After stopping state, it follows the operation described under “After stopping,” independent of the actual motor speed.

*4 The position error is always cleared to zero.

Pn507	Stop Selection with Main Power Supply OFF						All
Setting range	0 to 9	Unit	–	Default setting	0	Cycle the power supply	–

Explanation of Set Values

Set value	Description		
	During deceleration ^{*3}	After stopping	Error counter
0	Dynamic brake operation	Dynamic brake operation	Clear ^{*4}
1	Free-run	Dynamic brake operation	Clear ^{*4}
2	Dynamic brake operation	Servo-free	Clear ^{*4}
3	Free-run	Servo-free	Clear ^{*4}
4	Dynamic brake operation	Dynamic brake operation	Hold ^{*2}
5	Free-run	Dynamic brake operation	Hold ^{*2}
6	Dynamic brake operation	Servo-free	Hold ^{*2}
7	Free-run	Servo-free	Hold ^{*2}
8	Immediate stop ^{*1}	Dynamic brake operation	Clear ^{*4}
9	Immediate stop ^{*1}	Servo-free	Clear ^{*4}

- If an alarm occurs with the main power supply OFF, the Servomotor will operate according to the value set in Stop Selection for Alarm Detection (Pn510). If the main power supply is turned OFF with the servo ON and Undervoltage Alarm Selection (Pn508) is set to 1, the Servomotor will operate according to the value set in Stop Selection for Alarm Detection (Pn510) because a Main Power Supply Undervoltage (AC cut-off detection) alarm (Alarm No. 13.1) occurs.
- The dynamic brake is designed only for immediate stop. Configure the system to stop for about three minutes after the dynamic brake operates.

*1 “Immediate stop” means stopping the Servomotor immediately by using control with the servo ON. The torque command value at this time is limited by the value set in Immediate Stop Torque (Pn511).

*2 If the position command is supplied continuously or if the Servomotor rotates continuously with the main power supply OFF, a Error Counter Overflow (Alarm No. 24.0) may occur due to the accumulation of position errors. In addition, if the servo turns ON with a large position error, the Servomotor may start moving suddenly because the control attempts to zero the error. Take extra care when using the Servo Drive with this parameter set to hold the position error counter content.

*3 “During deceleration” means the period until the motor decreases its speed to 30 r/min or less from the normal operation. Once the Servomotor decelerates to 30 r/min or lower and falls in an After stopping state, it follows the operation described under “After stopping,” independent of the actual motor speed.

*4 The position error counter content will be always cleared to zero with these settings.

Pn508	Undervoltage Alarm Selection						All
Setting range	0 to 1	Unit	–	Default setting	1	Cycle the power supply	–

Explanation of Set Values

Set value	Description
0	The servo is turned OFF based on the value set in Stop Selection with Main Power Supply OFF (Pn507). The servo is then turned back ON when the main power supply is turned ON.
1	A Main Power Supply Undervoltage alarm (Alarm No. 13.1) occurs, causing an alarm trip.

Pn509	Momentary Hold Time						All
Setting range	70 to 2,000	Unit	1 ms	Default setting	70	Cycle the power supply	Required

- Set the Main Power Supply Alarm detection time.
- When set to 2,000, the main power supply OFF detection is disabled.

Pn510	Stop Selection for Alarm Detection						All
Setting range	0 to 7	Unit	–	Default setting	0	Cycle the power supply	–

Explanation of Set Values

Set value	Description		
	During deceleration ^{*3}	After stopping	Error counter
0	Dynamic brake operation	Dynamic brake operation	Clear ^{*1}
1	Free-run	Dynamic brake operation	Clear ^{*1}
2	Dynamic brake operation	Servo-free	Clear ^{*1}
3	Free-run	Servo-free	Clear ^{*1}
4	Operation A: Immediate stop ^{*2} Operation B: Dynamic brake operation	Dynamic brake operation	Clear ^{*1}
5	Operation A: Immediate stop ^{*2} Operation B: Free-run	Dynamic brake operation	Clear ^{*1}
6	Operation A: Immediate stop ^{*2} Operation B: Dynamic brake operation	Servo-free	Clear ^{*1}
7	Operation A: Immediate stop ^{*2} Operation B: Free-run	Servo-free	Clear ^{*1}

- Set the operation after stopping or during deceleration of the Servomotor when any protective function of the drive operates for an alarm detection.
- The dynamic brake is designed only for immediate stop. Configure the system to stop for about three minutes after the dynamic brake operates.

*1 The error counter is cleared when the alarm is reset.

*2 Operation A and B indicate whether immediate stop is executed when an alarm occurs. If an immediate stop alarm occurs, immediate stop in operation A is executed. If an alarm that does not support immediate stop occurs, stop in operation B is executed.

*3 "During deceleration" means the period from the motor is running until the motor speed reaches 30 r/min or lower. Once the motor reaches 30 r/min or lower and changes to the after stopping status, following operation is based on the after stopping status regardless of the motor speed.

● Immediate Stop Operation when an Alarm that Supports Immediate Stop Occurred

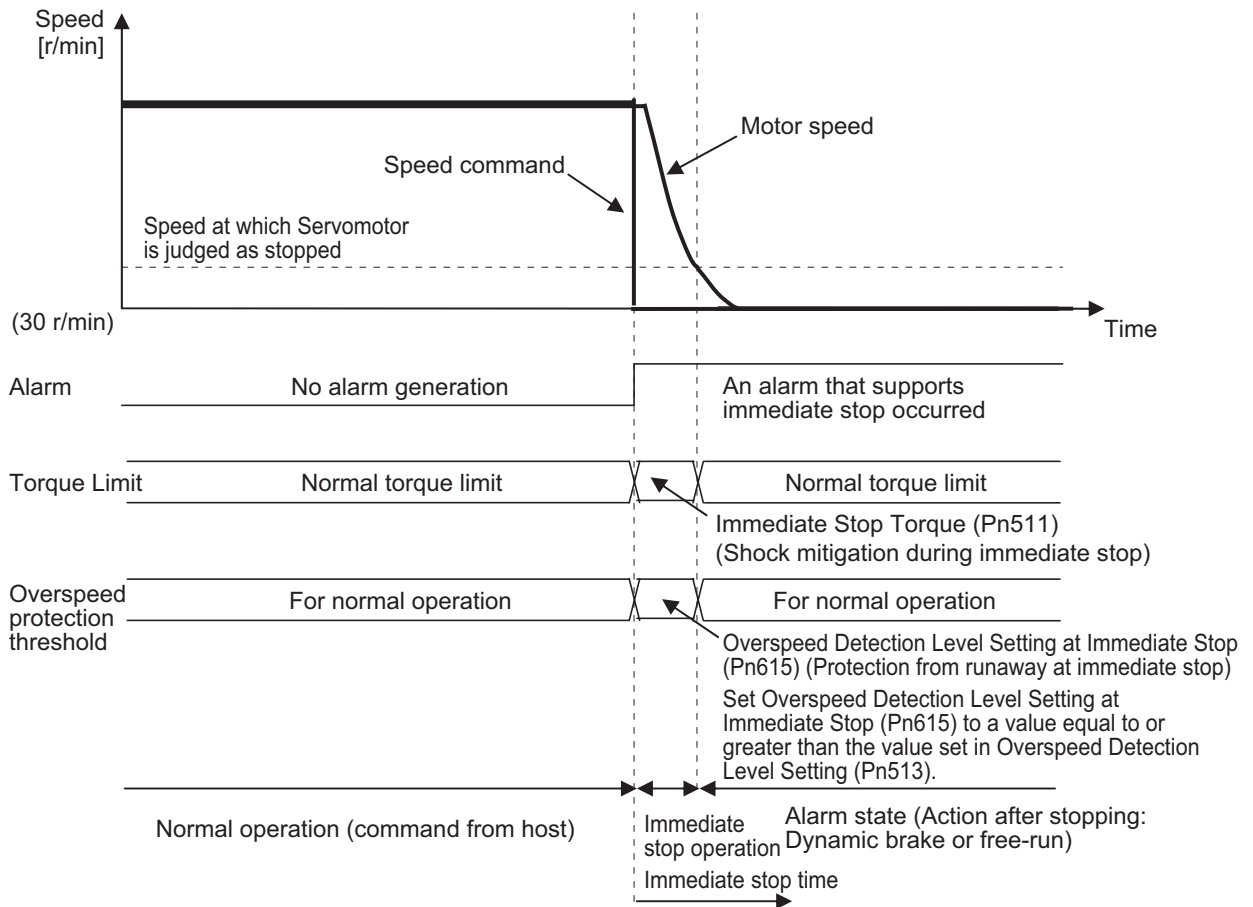

- If the actual rotation speed is not lower than 30 r/min even when the time set in Alarm Detection Allowable Time Setting (Pn614) has elapsed, an alarm state will occur immediately. In addition, if an alarm that does not support the immediate stop function occurs in the Servo Drive during an immediate stop, an alarm state will occur immediately.
- To prevent the Servomotor from running out of control during an immediate stop, set an allowable overspeed level in Overspeed Detection Level Setting at Immediate Stop (Pn615). An Overspeed 2 alarm (Alarm No. 26.1) does not support the immediate stop function and, if it occurs, causes an alarm trip. However, if this allowable level is lower than the value set in Overspeed Detection Level Setting (Pn513), the Servomotor does not stop immediately because the Overspeed 2 alarm (Alarm No. 26.1) occurs before the Overspeed alarm (Alarm No. 26.0). The Servomotor also does not stop immediately if Alarm No. 26.0 and Alarm No. 26.1 are detected simultaneously because, even though Alarm No. 26.0 is indicated, Alarm No. 26.1 is also generated internally.

Pn511	Immediate Stop Torque						All
Setting range	0 to 500	Unit	%	Default setting	0	Cycle the power supply	-

- Set the torque limit for the following cases.
 - During deceleration with Stop Selection for Drive Prohibition Input (Pn505) set to 2
 - During deceleration with Stop Selection with Main Power Supply OFF (Pn507) set to 8 or 9
 - During deceleration with Stop Selection with Servo OFF (Pn506) set to 8 or 9
- The normal torque limit is used if this parameter is set to 0.
- The unit is 0.1% of the rated torque.

Pn512	Overload Detection Level Setting						All
Setting range	0 to 500	Unit	%	Default setting	0	Cycle the power supply	–

- Set the overload detection level.
- The value is regarded as 115% if set to 0.
- The value is regarded as 115% also if set to more than 115.
- The unit is a percentage (%) of the rated torque.

Pn513	Overspeed Detection Level Setting						All
Setting range	0 to 20,000	Unit	r/min	Default setting	0	Cycle the power supply	–

- Set the overspeed detection level.
- The overspeed detection level is 1.2 times the maximum rotation speed of the Servomotor if set to 0.
- This parameter should normally be set to 0. The setting should be changed only when it is necessary to lower the overspeed detection level.
- The set value of this parameter is limited to 1.2 times the maximum rotation speed of the Servomotor.
- The detection margin of error for the set value is ± 36 r/min for a 5-core incremental encoder.

Pn514	Overrun Limit Setting						Position
Setting range	0 to 1,000	Unit	0.1 rotation	Default setting	10	Cycle the power supply	–

- Set the allowable operating range for the position command input range.
- If the set value is exceeded, an Overrun Limit Error will occur.

Without position command input

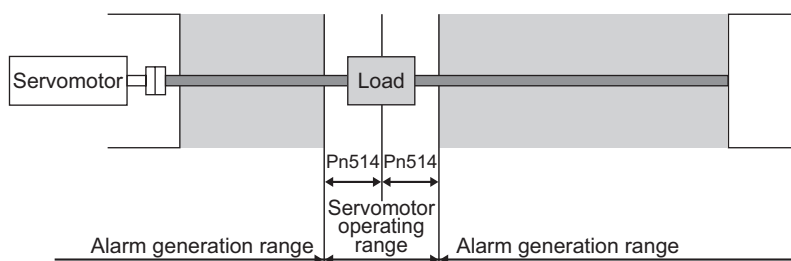

With position command input

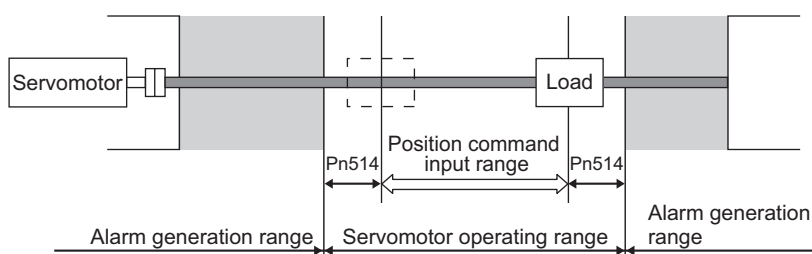

Pn515	Control Input Signal Read Setting						All
Setting range	0 to 3	Unit	–	Default setting	0	Cycle the power supply	Required

Explanation of Set Values

Set value	Description
0	0.166 ms
1	0.333 ms
2	1 ms
3	1.666 ms

- Select the signal read cycle for control signals.

Pn516	Alarm Reset Condition Setting						All
Setting range	0 to 1	Unit	–	Default setting	0	Cycle the power supply	Required

Explanation of Set Values

Set value	Description
0	120 ms
1	Follow the setting of Control Input Signal Read Setting (Pn515).

- Select the time during which the RESET signal must last to be recognized as an Alarm Reset Input signal.

Pn517	Error Counter Reset Condition Selection						Position
Setting range	0 to 4	Unit	–	Default setting	3	Cycle the power supply	–

Explanation of Set Values

Set value	Description
0	Disabled
1	Clear the error counter at level when the signal is shorted for 500 μ s or longer.
2	Clear the error counter at level when the signal is shorted for 1 ms or longer.
3	Clear the error counter at edge when the signal changes from open to shorted for 100 μ s or longer.
4	Clear the error counter at edge when the signal changes from open to shorted for 1 ms or longer.

- The minimum duration of the RESET input signal when the parameter is set to 1 or 2 is as follows.

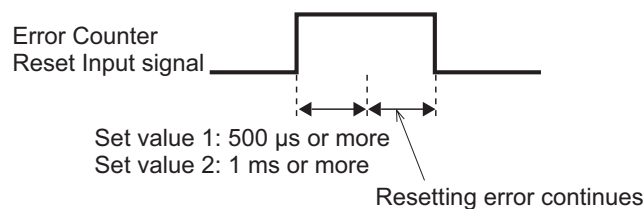

- The minimum duration of the RESET input signal when the parameter is set to 3 or 4 is as follows.

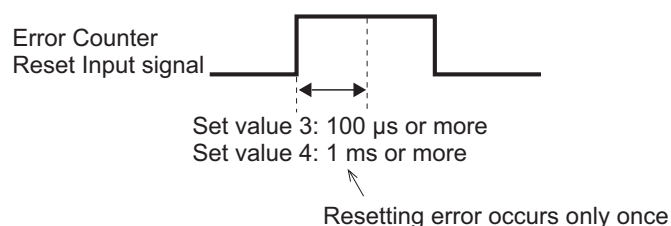

Pn518	Command Pulse Prohibition Input Setting						Position
Setting range	0 to 1	Unit	–	Default setting	1	Cycle the power supply	–

Explanation of Set Values

Set value	Description
0	Enabled
1	Disabled

- Select whether to enable or disable the Pulse Prohibition Input (IPG). The command pulse input counting process will be force-stopped when the Command Pulse Prohibition input is enabled.

Pn519	Command Pulse Prohibition Input Read Setting						Position
Setting range	0 to 4	Unit	–	Default setting	0	Cycle the power supply	Required

Explanation of Set Values

Set value	Description
0	0.166 ms
1	0.333 ms
2	1 ms
3	1.666 ms
4	0.166 ms (No judgment of multiple matches)

- Select the signal read cycle for the Pulse Prohibition Input (IPG).
- The signal status is updated when the signal status in each signal read cycle that has been set matches multiple times.
- The possibility of malfunction due to noise can be reduced by lengthening the signal read cycle. However, the responsiveness to signal input will be degraded.

Pn520	Position Setting Unit Selection						Position
Setting range	0 to 1	Unit	–	Default setting	0	Cycle the power supply	Required

Explanation of Set Values

Set value	Description
0	Command unit
1	Encoder unit

- Select the setting unit of Positioning Completion Range 1 and 2 (Pn431 and Pn442) and Error Counter Overflow Level (Pn014).

Pn521	Torque Limit Selection						Position	Speed
Setting range	0 to 6	Unit	–	Default setting	1	Cycle the power supply	–	

Explanation of Set Values

Torque Limit Selection (Pn521)	Torque Limit Switching (TLSEL)	Torque Limit Switching Setting 1/2 (Pn523/Pn524)	Forward direction torque limit	Reverse direction torque limit
0				
1	–	–	Pn013	
2	–	–	Pn013	Pn522
3	OFF	Enabled	Pn013	
	ON	Enabled	Pn522	
4				
5				
6	OFF	–	Pn013	Pn522
	ON	–	Pn525	Pn526

- Set the torque limit method for forward/reverse direction.
- If the parameter is set to 0, the forward and reverse torque limit inputs are limited by No. 1 Torque Limit (Pn013).

Pn522	No. 2 Torque Limit						Position	Speed
Setting range	0 to 500	Unit	%	Default setting	500	Cycle the power supply	–	

- Set the second output torque limit of the Servomotor (Pn013: No. 1 Torque Limit and Pn522: No. 2 Torque Limit).
- For torque limit selection, refer to Torque Limit Selection (Pn521).
- Make the setting as a percentage of the rated torque.
Example: When the maximum torque is limited to 150%

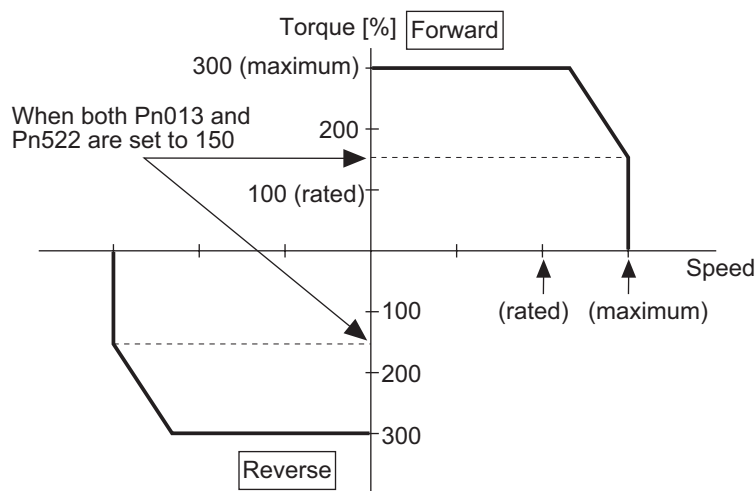

Pn523	Torque Limit Switching Setting 1						Position	Speed
Setting range	0 to 4,000	Unit	ms/100%	Default setting	0	Cycle the power supply	–	

- Set the rate of change when switching from No.1 Torque Limit to No.2 Torque Limit.
- When set to 0, switching takes place immediately.

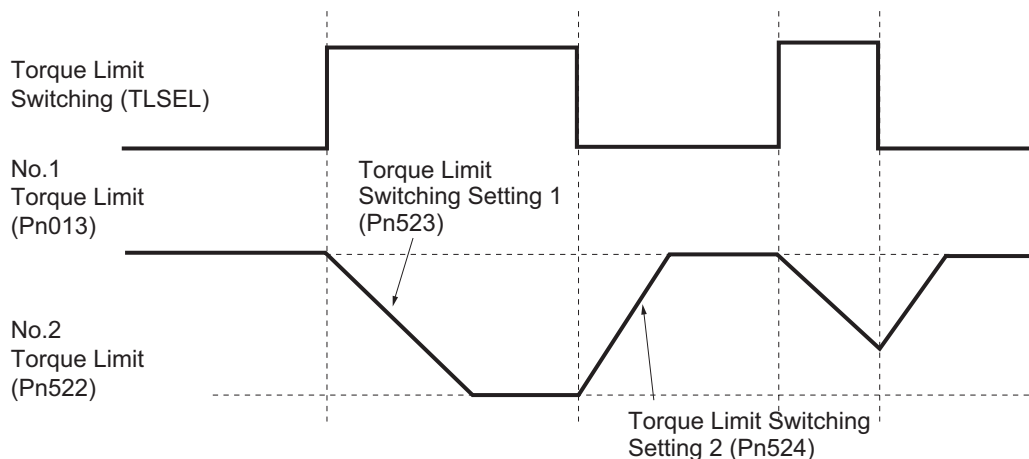

Pn524	Torque Limit Switching Setting 2						Position	Speed
Setting range	0 to 4,000	Unit	ms/100%	Default setting	0	Cycle the power supply	–	

- For this parameter, set the same value as for Torque Limit Switching Setting 1 (Pn523).

Pn525	Forward External Torque Limit						Position	Speed
Setting range	0 to 500	Unit	%	Default setting	500	Cycle the power supply	–	

- Set the forward external torque limit for the torque limit switching input.
- The unit is 0.1% of the rated torque.

Pn526	Reverse External Torque Limit						Position	Speed
Setting range	0 to 500	Unit	%	Default setting	500	Cycle the power supply	–	

- Set the reverse external torque limit for the torque limit switching input.
- The unit is 0.1% of the rated torque.

Pn527	Reserved						Position	Speed
Setting range	30	Unit	–	Default setting	30	Cycle the power supply	–	

- Do not set.

Pn528	Default Display						All
Setting range	0 to 35	Unit	–	Default setting	1	Cycle the power supply	Required

Explanation of Set Values

Set value	Description
0	Position command error
1	Motor speed
2	Position command speed
3	Speed control command
4	Torque command
5	Total encoder pulses
6	Total command pulses
8	Reserved (Do not set.)
9	Control mode
10	I/O signal status
11	Reserved (Do not set.)
12	Alarm factor, history
13	Warning number
14	Regeneration resistance load ratio
15	Overload load ratio
16	Inertia ratio
17	Reason for no rotation
18	Display of the number of I/O signal changes
20	Reserved (Do not set.)
21	Reserved (Do not set.)
22	Monitor for the number of encoder communications errors
23	Reserved (Do not set.)
24	Position error (for each encoder)
25	Reserved (Do not set.)
26	Reserved (Do not set.)
27	P-N voltage
28	Software version
29	Drive serial number
30	Motor serial number
31	Accumulative operation time
32	Automatic motor recognition function
33	Temperature information
35	Reserved (Do not set.)

- Select the type of data to be displayed by default on the 7-segment front panel display when the power supply is powered on.

- For details about the display, refer to *8-4 Mode Setting* on page 8-6.

Pn531	Reserved						
Setting range	1	Unit	–	Default setting	1	Cycle the power supply	–

- Do not set.

Pn532	Command Pulse Input Maximum Setting						<input type="text" value="Position"/>
Setting range	250 to 4,000	Unit	Kpps	Default setting	4,000	Cycle the power supply	Required

- Set the maximum command pulse input value. A Command Pulse Frequency Error (Alarm No. 27.0) occurs if the command pulse input frequency exceeds this value x 1.2.
- The Servo Drive detects the Command Pulse Frequency Error for pulses it has accepted. Therefore, it may not detect the error if the number of input pulses is much larger than the value set in this parameter. In addition, setting the value to 1,000 or less enables the use of the digital filter for the command pulse input as shown in the table below.

Pn532 set value	Digital filter
250 to 499	200 ns x 2 readings
500 to 999	100 ns x 2 readings
1,000 to 4,000	None (through)

Pn533	Pulse Regeneration Output Limit Setting						<input type="text" value="All"/>
Setting range	0 to 1	Unit	–	Default setting	0	Cycle the power supply	Required

Explanation of Set Values

Set value	Description
0	Error detection disabled
1	Error detection enabled

- Set whether to enable or disable the detection of the Pulse Regeneration Error (Alarm No. 28.0).

Pn535	Front Key Protection Setting						<input type="text" value="All"/>
Setting range	0 to 1	Unit	–	Default setting	0	Cycle the power supply	Required

Explanation of Set Values

Set value	Description
0	Front panel operation not restricted
1	Front panel operation restricted

- Set whether or not to restrict operations on the front panel.
- The restricted operation varies depending on the mode as shown in the table below.

Mode	Operations restricted
Monitor Mode	All monitor data can be viewed.
Parameter Setting Mode	Parameters cannot be changed. However, set parameter values can be viewed.
EEPROM Write Mode	Unavailable (Not displayed)
Ancillary Function Mode	Operations other than disabling the front key protection setting are unavailable (not displayed).

7-7 Special Parameters

Pn600	Reserved						
Setting range	0	Unit	–	Default setting	0	Cycle the power supply	–

- Do not set.

Pn602	Excessive Speed Error Setting						<input type="text" value="All"/>
Setting range	0 to 20,000	Unit	r/min	Default setting	0	Cycle the power supply	–

- Set the detection level for Excessive Speed Error (Alarm No. 24.1).
- When set to 0, the detection of Excessive Speed Error is disabled.

Pn604	Jog Speed						<input type="text" value="All"/>
Setting range	0 to 500	Unit	r/min	Default setting	300	Cycle the power supply	–

- Set the command speed for trial JOG operation (speed control).

Pn605	Gain 3 Effective Time						<input type="text" value="Position"/>
Setting range	0 to 10,000	Unit	0.1 ms	Default setting	0	Cycle the power supply	–

- Set effective time of Gain 3 for 3-step gain switching.

Pn606	Gain 3 Ratio Setting						<input type="text" value="Position"/>
Setting range	50 to 1,000	Unit	%	Default setting	100	Cycle the power supply	–

- Set Gain 3 as a multiple of Gain 1.

Pn607	Torque Command Value Offset						<input type="text" value="All"/>
Setting range	–100 to 100	Unit	%	Default setting	0	Cycle the power supply	–

- Set the offset torque to add to torque commands.
- The unit is a percentage (%) of the rated torque.

Pn608	Forward Direction Torque Offset						<input type="text" value="All"/>
Setting range	–100 to 100	Unit	%	Default setting	0	Cycle the power supply	–

- Set the value to be added to torque commands for operation in the forward direction.
- The unit is a percentage (%) of the rated torque.

Pn609	Reverse Direction Torque Offset						<input type="text" value="All"/>
Setting range	–100 to 100	Unit	%	Default setting	0	Cycle the power supply	–

- Set the value to add to torque commands for operation in the reverse direction.
- The unit is a percentage (%) of the rated torque.

Pn610	Function Expansion Setting						<input type="text" value="Position"/>
Setting range	0 to 63	Unit	–	Default setting	0	Cycle the power supply	–

- Enable or disable the extended function allocated to each bit.

Bit	Function	Set value	
		0	1
bit 0	Instantaneous speed observer function	Disabled	Enabled
bit 1	Disturbance observer function	Disabled	Enabled
bit 2	Disturbance observer operation setting	Always enabled	Only when Gain 1 is selected
bit 3	Inertia ratio switching function	Disabled	Enabled
bit 4	Electric current response improvement function	Disabled	Enabled
bit 5	Disabled	–	–

Set the decimal value that is converted from the bit values.

[Example]

Instantaneous speed observer function: Enabled

Disturbance observer function: Enabled

Disturbance observer operation setting: Always enabled

Inertia ratio switching function: Disabled

Electric current response improvement function: Enabled

With the above settings, the value in each bit is expressed as 10011, which is 19 in decimal. Therefore, set the parameter to 19.

Pn611	Electric Current Response Setting						<input type="text" value="All"/>
Setting range	50 to 100	Unit	%	Default setting	100	Cycle the power supply	–

- Make fine adjustment to electric current response. The default setting is 100%.

Pn613	Inertia Ratio 2						<input type="text" value="All"/>
Setting range	0 to 10,000	Unit	–	Default setting	250	Cycle the power supply	–

- Set the second load inertia as a percentage of the motor rotor inertia.

Pn614	Alarm Detection Allowable Time Setting						All
Setting range	0 to 1,000	Unit	ms	Default setting	200	Cycle the power supply	–

- Set the time required for the Brake Interlock Output (BKIR: CN1 pin 10) to turn OFF after the Operation Command (RUN: CN1 pin 29) is detected to be OFF, when servo OFF status is entered while the Servomotor is operating. When the Operation Command (RUN) turns OFF while the Servomotor is operating, the motor decelerates to reduce rotation speed, and the Brake Interlock Output (BKIR) turns ON after the set time elapsed.

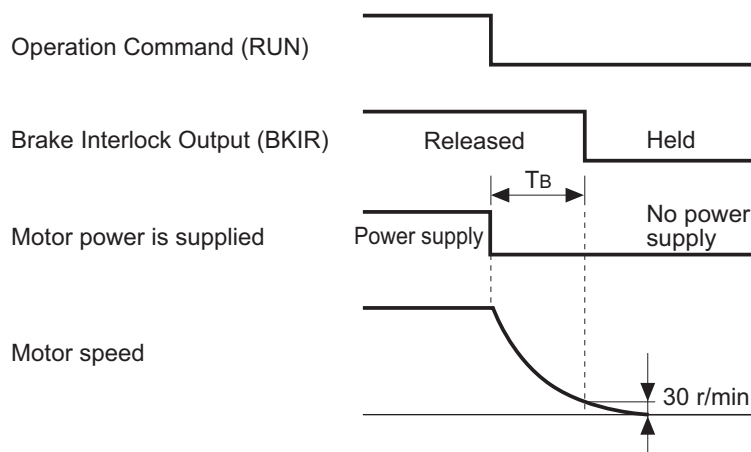

“ T_B ” in the above figure is the setting time in Brake Timing During Operation or the time until the motor rotation speed falls to 30 r/min or lower, whichever is shorter.

- For details, refer to 6-6 *Brake Interlock* on page 6-18.

Pn615	Overspeed Detection Level Setting at Immediate Stop						All
Setting range	0 to 20,000	Unit	r/min	Default setting	0	Cycle the power supply	–

- Set the overspeed detection level in the event of an immediate stop alarm.
- The overspeed detection level is 1.2 times the maximum rotation speed of the Servomotor if this parameter is set to 0.
- This parameter should normally be set to 0. The setting should be changed only when it is necessary to lower the overspeed detection level.
- The set value of this parameter is limited to 1.2 times the maximum rotation speed of the Servomotor.

Pn616	Reserved						All
Setting range	1	Unit	–	Default setting	1	Cycle the power supply	–

- Do not set.

Pn617	Front Panel Parameter Write Selection						All
Setting range	0 to 1	Unit	–	Default setting	0	Cycle the power supply	Required

Explanation of Set Values

Set value	Description
0	Writing to the EEPROM is not performed simultaneously with parameter changes.
1	Writing to the EEPROM is performed simultaneously with parameter changes.

- Select whether to write to the EEPROM when a parameter is changed from the front panel.

Pn618	Power Supply ON Initialization Time						All
Setting range	0 to 100	Unit	0.1 s	Default setting	0	Cycle the power supply	Required

- Set the initialization time after turning ON the power supply to the standard 1.5 seconds plus the specified value.

Pn619	Encoder Phase-Z Setting						All
Setting range	0 to 32,767	Unit	Pulses	Default setting	0	Cycle the power supply	Required

- Make fine adjustment to the encoder phase-Z width if the number of pulses per motor rotation after pulse output dividing is not an integer.

Pn620	Reserved						
Setting range	0	Unit	–	Default setting	0	Cycle the power supply	–

- Do not set.

Pn621	Reserved						
Setting range	0	Unit	–	Default setting	0	Cycle the power supply	–

- Do not set.

Pn622	Reserved						
Setting range	0	Unit	–	Default setting	0	Cycle the power supply	–

- Do not set.

Pn623	Disturbance Torque Compensation Gain						Position
Setting range	–100 to 100	Unit	%	Default setting	0	Cycle the power supply	–

- Set the compensation gain for the disturbance torque.

Pn624	Disturbance Observer Filter Setting						Position
Setting range	10 to 2,500	Unit	0.01 ms	Default setting	53	Cycle the power supply	–

- Set the filter time constant for disturbance torque compensation.

Pn627	Warning Latch Hold Time Selection						All
Setting range	0 to 10	Unit	–	Default setting	5	Cycle the power supply	Required

Explanation of Set Values

Set value	Description
0	Latch time infinite
1 to 10	Latch time 1 to 10 seconds

Pn628	Not used						All
Setting range	–	Unit	–	Default setting	–	Cycle the power supply	–

Pn631	Realtime Autotuning Estimated Speed Selection						All
Setting range	0 to 3	Unit	–	Default setting	1	Cycle the power supply	–

Explanation of Set Values

Set value	Description
0	Fix the estimated result when load estimation is stabilized.
1	Estimate every minute from the load characteristic changes.
2	Estimate every second from the load characteristic changes.
3	Estimate the optimum from the load characteristic changes.

Pn632	Realtime Autotuning Customization Mode Setting						All
Setting range	–32,768 to 32,767	Unit	–	Default setting	0	Cycle the power supply	–

- Set the details of the autotuning function when Realtime Autotuning Mode Selection (Pn002) is set to 6.
- For realtime autotuning, refer to 9-2 *Realtime Autotuning* on page 9-4.

Explanation of Set Values

Bit	Name	Description
0 to 1	Load characteristic estimation ^{*1}	Select to enable or disable load characteristic estimation. 0: Disabled 1: Enabled
2 to 3	Inertia ratio updating	Select whether to update the value set in Inertia Ratio 1 (Pn004) with the load characteristic estimation result. 0: Uses the present set value. 1: Updates with the estimation result.

Bit	Name	Description
4 to 6	Torque compensation	Select whether to update the values set in Torque Command Value Offset (Pn607), Forward Direction Torque Offset (Pn608), and Reverse Direction Torque Offset (Pn609) with the load characteristic estimation result. 0: Use the present set value. 1: Disable torque compensation. Clear the above parameters to zero. 2: Vertical mode. Update Pn607 and clear Pn608 and Pn609 to zero. 3: Friction compensation (small). Update Pn607 and set small compensation values in Pn608 and Pn609. 4: Friction compensation (intermediate). Update Pn607 and set intermediate compensation values in Pn608 and Pn609. 5: Friction compensation (large). Update Pn607 and set large compensation values in Pn608 and Pn609.
7	Rigidity setting	Select to enable or disable the basic gain setting by Realtime Autotuning Machine Rigidity Setting (Pn003). 0: Disabled 1: Enabled
8	Fixed parameter setting	Select whether to allow changes to fixed parameters that normally are set to fixed values. 0: Use the present values. 1: Set to fixed values.
9 to 10	Gain switch setting	Select the method to set parameters that relate to gain switching while realtime autotuning is enabled. 0: Use the present settings. 1: Disable gain switching. 2: Enable gain switching.

*1 When load characteristic estimation is disabled, setting to update the inertia ratio with the estimation result does not cause the present value to change. Also, setting to update the torque compensation value with the estimation result causes load characteristic estimation to be disabled.



Precautions for Safe Use

This parameter must be set in units of bits. Unexpected operation may occur if the bits are not set correctly. Set this parameter with care.



Additional Information

How to Set the Parameter Bits

Follow these steps to calculate the set value, when you make any setting other than 0.

(1) Confirm the least significant bit (LSB) in each set value.

E.g. LSB of Torque compensation function: 4

(2) Multiply the set value by 2 raised to the power of the bit number of the LSB.

E.g. To set torque compensation to "Friction compensation (small)":

$$2^4 \times 3 = 48$$

(3) Repeat Step (1) and (2) for each bit setting. Set the sum of all bit values in Pn632.

E.g. The calculation formula is as shown below for the following settings:

Load characteristic estimation = Enabled, Inertia ratio updating = Enabled,
Torque compensation = Friction compensation (small), Rigidity setting = Enabled,
Fixed parameter setting = Set to fixed values, and Gain switch setting = Enabled

$$2^0 \times 1 + 2^2 \times 1 + 2^4 \times 3 + 2^7 \times 1 + 2^8 \times 1 + 2^9 \times 2 = 1461$$

Pn633	Reserved						
Setting range	1,000	Unit	–	Default setting	1,000	Cycle the power supply	–

- Do not set.

Pn634	Reserved						
Setting range	0	Unit	–	Default setting	0	Cycle the power supply	–

- Do not set.

Pn635	Reserved						
Setting range	10	Unit	–	Default setting	10	Cycle the power supply	–

- Do not set.

Pn637	Vibration Detection Threshold						All
Setting range	0 to 1,000	Unit	0.1%	Default setting	0	Cycle the power supply	–

- Set the vibration detection threshold.
- If torque vibration that exceeds this setting is detected, a vibration detection warning occurs.
- The unit is 0.1% of the rated torque.

Pn638	Warning Mask Setting						All
Setting range	–32,768 to 32,767	Unit	–	Default setting	4	Cycle the power supply	Required

- Set a mask for warning detection.
- If you set the corresponding bit to 1, the corresponding warning detection is disabled.
- For the setting method, refer to *10-2 Warning List* on page 10-5.



Precautions for Correct Use

Pn700 to Pn799 and Pn800 to Pn899 are not used. Do not change the settings.



Operation

This section gives the operational procedure and explains how to operate in each mode.

8-1	Operational Procedure	8-2
8-2	Preparing for Operation	8-3
8-2-1	Items to Check Before Turning ON the Power Supply	8-3
8-2-2	Turning ON the Power Supply	8-4
8-2-3	Checking the Display	8-4
8-3	Using the Front Panel Display	8-5
8-4	Mode Setting	8-6
8-4-1	Changing the Mode	8-6
8-4-2	Monitor Mode	8-7
8-4-3	Parameter Setting Mode	8-19
8-4-4	Parameter Write Mode	8-21
8-4-5	Auxiliary Function Mode	8-22
8-5	Trial Operation	8-28
8-5-1	Preparations for Trial Operation	8-28
8-5-2	Trial Operation in Position Control Mode	8-29

8-1 Operational Procedure

Turn ON the power supply after correct installation and wiring and check the operation of the Servomotor and Servo Drive individually.

Then make the function settings as required according to the use of the Servomotor and Servo Drive.

If user parameters are set incorrectly, there is a risk of unexpected motor operation, which can be dangerous. Set user parameters accurately according to the setting methods in this User's Manual.

Item	Description	Reference
Mounting and installation	Install the Servomotor and Servo Drive according to the installation conditions. (Do not connect the Servomotor to mechanical systems before checking the operation with no-load.)	Section 4, 4-1
↓		
Wiring and connections	Connect the Servomotor and Servo Drive to the power supply and peripheral equipment. Specified installation and wiring conditions must be satisfied, particularly for models conforming to the EC Directives.	Section 4, 4-2
↓		
Preparing for operation	Check the necessary items and then turn ON the commercial power supply. Check on the display to see whether there are any internal errors in the Servo Drive.	Section 8, 8-2
↓		
Function settings	Set the user parameters related to the functions required for application conditions.	Section 7
↓		
Trial operation	First, check motor operation with no-load. Then turn the power supply OFF and connect the Servomotor to mechanical systems. Turn ON the power supply again, and check to see whether protective functions, such as the immediate stop and operational limits, are functioning properly. Check operation at both low speed and high speed using the system without a workpiece, or with dummy workpieces.	Section 8, 8-5
↓		
Adjustment	Manually adjust the gain if necessary. Further adjust the various functions to improve the control performance.	Section 9
↓		
Operation	Operation can now be started. When any problems occur, refer to <i>Section 10 Troubleshooting and Maintenance</i> .	Section 10

8-2 Preparing for Operation

This section explains the procedure to prepare the Servomotor and Servo Drive for operation on completion of installation and wiring. It explains items to check both before and after turning ON the power supply.

8-2-1 Items to Check Before Turning ON the Power Supply

Checking Power Supply Voltage

- Check to be sure that the power supply voltage is within the ranges shown below.

R88D-KP01H/02H/04H/08H/10H/15H (Single-phase or single-phase/3-phase 200 VAC input)

Main circuit power supply: Single-phase or single-phase/3-phase 200 to 240 VAC (170 to 264 VAC) 50/60 Hz

Control circuit power supply: Single-phase 200 to 240 VAC (170 to 264 VAC) 50/60 Hz

R88D-KP20H/30H/50H (3-phase 200 VAC input)

Main circuit power supply: 3-phase 200 to 230 VAC (170 to 253 VAC) 50/60 Hz

Control circuit power supply: Single-phase 200 to 230 VAC (170 to 253 VAC) 50/60 Hz

Checking Terminal Block Wiring

- The main circuit power supply inputs (L1/L3 or L1/L2/L3) must be properly connected to the terminal block.
- The control circuit power supply inputs (L1C/L2C) must be properly connected to the terminal block.
- The Servomotor's red (U), white (V), and blue (W) power lines and the green/yellow (\oplus) must be properly connected to the terminal block.

Checking the Servomotor

- There should be no load on the Servomotor. (Do not connect the mechanical system.)
- The Servomotor side power lines and the power cables must be securely connected.

Checking the Encoder Wiring

- The encoder cable must be securely connected to the encoder connector (CN2) of the Servo Drive.
- The encoder cable must be securely connected to the encoder connector of the Servomotor.

Checking the Control I/O Connector

- The control cable must be securely connected to the control I/O connector (CN1).
- The Operation Command (RUN) signal is OFF.

8-2-2 Turning ON the Power Supply

- Turn ON the control circuit power after you conduct the pre-power-ON checking. You can turn ON the main circuit power, but it is not a requirement.
- It will take approximately 2 seconds until the Alarm Output (/ALM) turns ON after the power supply is turned ON. Configure the host controller so that it does not detect any alarm during this period (if the power supply is powered ON with the host controller connected).

8-2-3 Checking the Display

Display on the Servo Drive

- The display on the Servo Drive changes as follows when the power supply is turned ON.

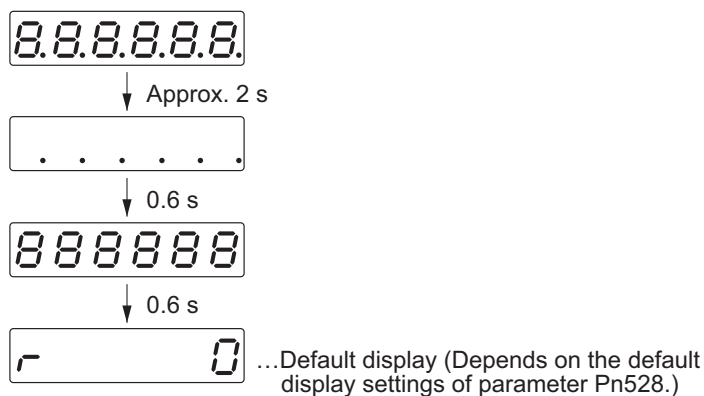

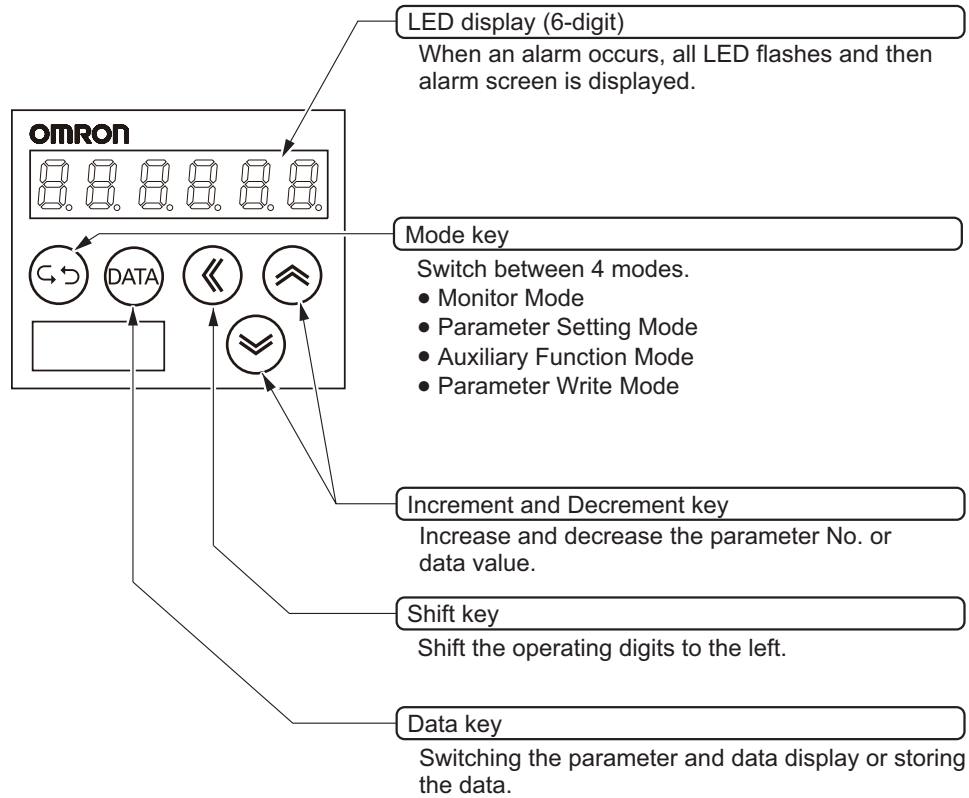

8-3 Using the Front Panel Display

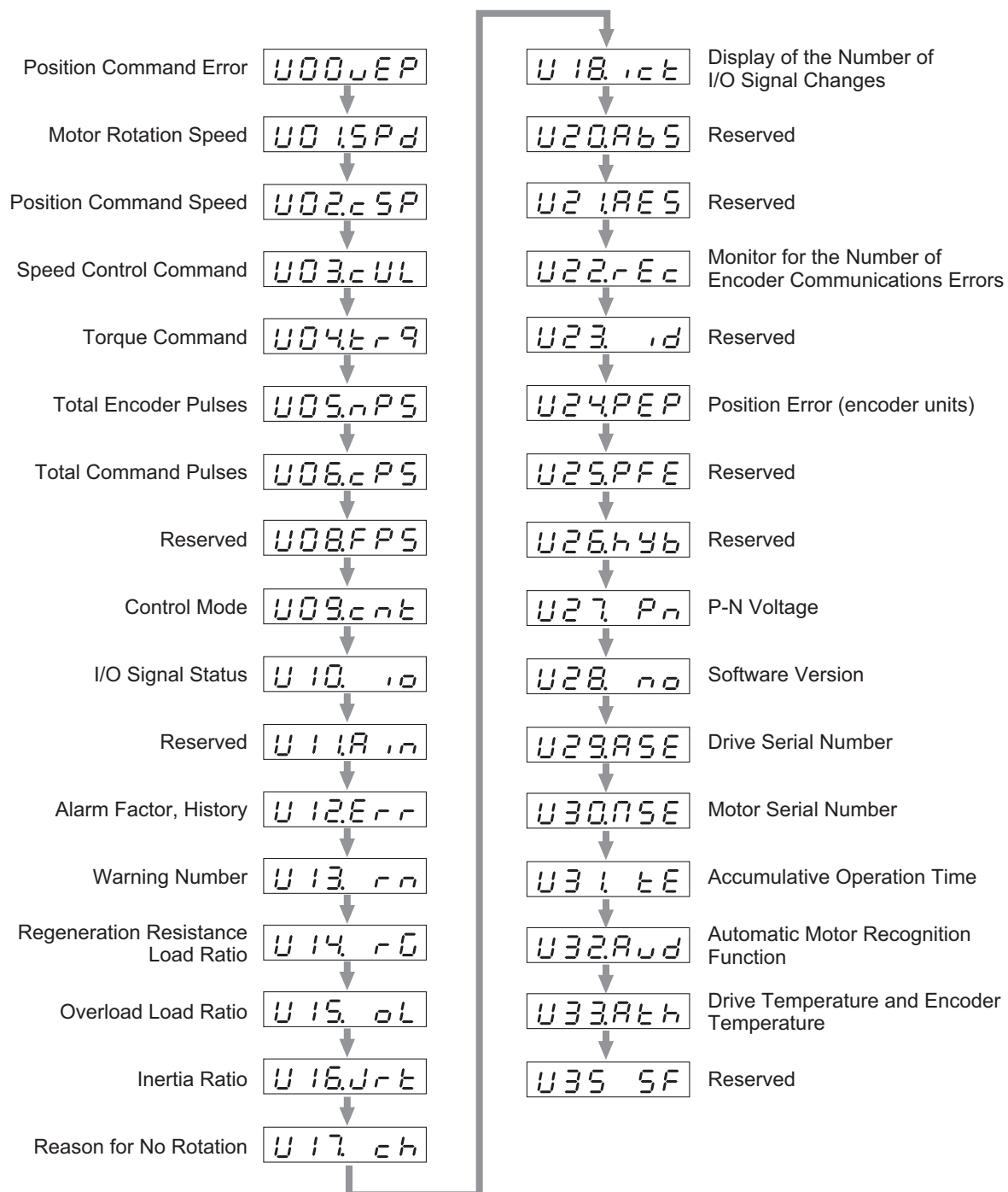

8-4-2 Monitor Mode



Press  to move in the direction of the arrow.
And press  to move in the opposite direction.

- The display shows the motor rotation speed when the power supply is turned ON for the first time after purchase. To change the display that appears when the power supply is turned ON, change the value set in Default Display (Pn528). For details, refer to Pn528 *Default Display* on page 7-53.

Position Command Error U00JEP

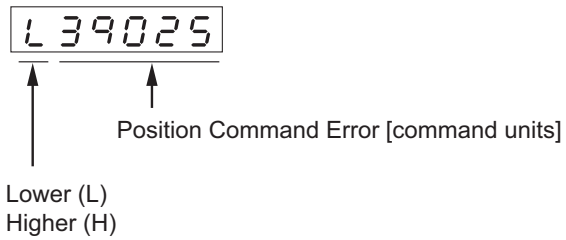

Press to switch Lower (L) and Higher (H).

L 39025 H 103

Motor Rotation Speed U01SPd

r 1000

- This indicates the motor rotation speed (unit: r/min).
- The minus (-) sign means that the Servomotor is operates in the reverse rotation.

Position Command Speed U02.cSP

r 1000

- This indicates the position command speed (unit: r/min).

Position Control Command U03.cVL

r 1000

- This indicates the speed control command (unit: r/min).

Torque Command U04.tF9

t 100.0

- This indicates the torque command value (%) of the Servo Drive.
- "100%" is displayed when the output from the Servo Drive is at rated torque.
- The minus (-) sign means the torque output when the Servomotor operates in the reverse rotation.

Total Encoder Pulses U05.nPS

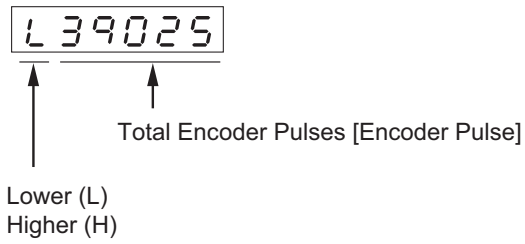

Press to switch Lower (L) and Higher (H).



Total Command Pulses U06.cPS



Press to switch Lower (L) and Higher (H).



Reserved U08.FPS

Do not set.

Control Mode U09.cent

- Po5cent Position control mode
- SPdcent Speed control mode
- tr9cent Reserved (Do not set any value.)
- FcLcent Reserved (Do not set any value.)

This indicates which control mode is in use: position control or speed control.

I/O Signal Status U10. 10

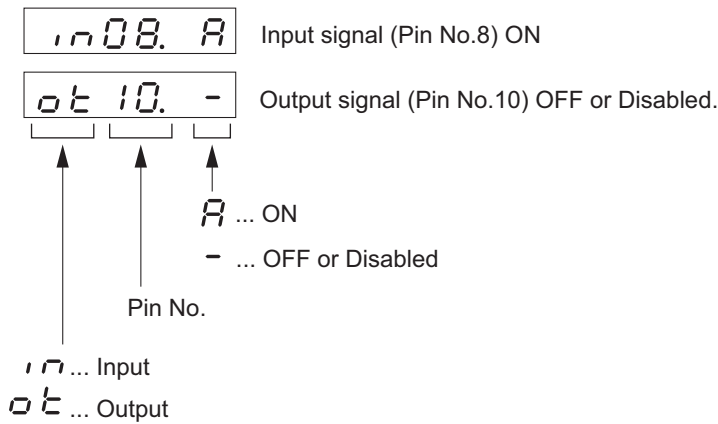

This indicates the status of the control input and output signals connected to CN1 pin.

● Switching between Input and Output Signals

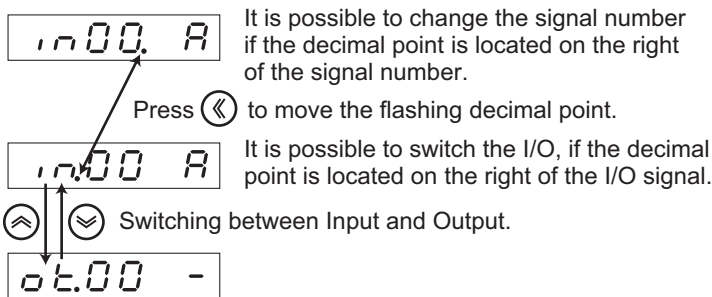

Press ⬆ ⬇ to select the signal No. that you want to monitor.

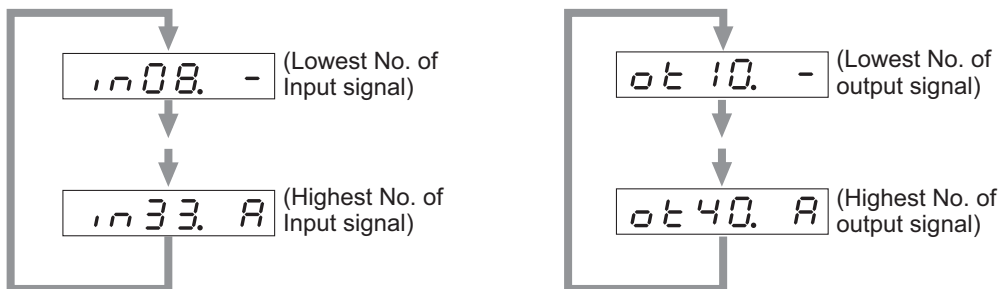

Reserved `U 11.A In`

Do not set.

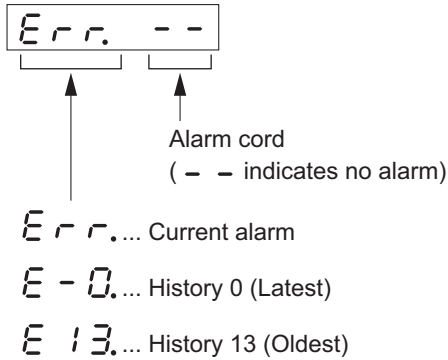
Alarm Factor, History `U 12.Err`

- The alarm history function enables you to trace the history of up to 14 most recent alarms including the current alarm.
- The display will flash if an alarm occurs.
- If an alarm that is recorded in the history occurs, the alarm code for the current alarm and for history 0 will be the same.
- "st" will flash on the display if Safety Input Error (Alarm No. 30.0) occurs.

● Alarm Codes and Description

Alarm code	Description	Alarm code	Description
11	Control Power Supply Undervoltage	26	Overspeed
12	Overvoltage	27	Electronic Gear Setting Error
13	Main Power Supply Undervoltage	34	Overrun Limit Error
14	Overcurrent	36	Parameter Error
15	Servo Drive Overheat	37	Parameter Destruction
16	Overload	38	Drive Prohibition Input Error
18	Regeneration Overload	44	Encoder 1-rotation Counter Error
21	Encoder Communications Error	45	Multi-rotation Counter Error
23	Encoder Communications Data Error	48	Encoder Phase-Z Error
24	Error Counter Overflow	49	Encoder CS Signal Error

Note The following alarms are not recorded in the history.

11: Control Power Supply Undervoltage

13: Main Power Supply Undervoltage

36: Parameter Error

37: Parameter Destruction

38: Drive Prohibition Input Error

95: Motor Non-conformity

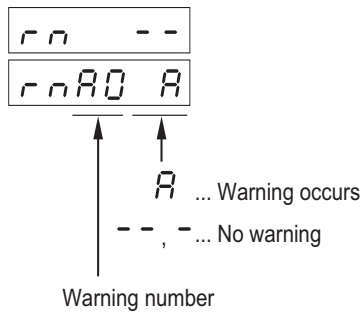
Warning Number U13. rn

Press to display the occurrence status of each warning.

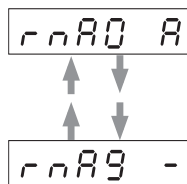
**Regeneration Load Ratio** U14. rG
rG 80.0

- This indicates the regeneration resistance load ratio as a percentage when the detection level for the regeneration overload is 100%.

Overload Load Ratio U15. oL
oL 1000

- This indicates the overload ratio as a percentage when the rated load is 100%.

Inertia Ratio U16. Jrt
J 100 The inertia ratio (%) is displayed.

Reasons for No Rotation U17 ch

A number is displayed to indicate the cause why the motor does not rotate.

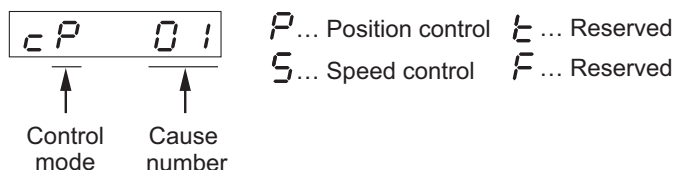

No.	Item	Related control mode	Description
Flashing	An alarm or warning occurred	All	An alarm or warning occurred.
0	No cause	All	No cause was detected. Normally, the Servomotor is rotating.
1	Main power cut off	All	The main power supply to the Servo Drive is not turned ON.
2	RUN input signal not turned ON	All	The Operation Command (RUN) signal is not connected to COM.
3	Drive prohibition input not enabled	All	When Pn504 is 0 (drive prohibition input enabled): <ul style="list-style-type: none"> • The forward drive prohibition input (POT) is open and the speed command is in the forward direction. • The reverse drive prohibition input (NOT) is open and the speed command is in the reverse direction.
4	Torque limit value too small	All	The torque limit value set in No. 1 Torque Limit (Pn013) or No. 2 Torque Limit (Pn522), whichever is enabled, is set to 5% or less of the rated torque.
6	IPG input enabled	P	IPG is open with Command Pulse Prohibition Input Setting (Pn518) set to 0 (enabled).
7	Command pulse input frequency too low	P	<ul style="list-style-type: none"> • Command pulse input is not correct. • Connection with the input selected in Pn005 is not correct. • The input pattern settings selected in Pn006 and Pn007 do not match, etc. Due to these causes, the number of command pulses per command cycle is decreased to 1 pulse or less.
8	ECRST input enabled	P	Error Counter Reset Input (ECRST) is connected to COM with Error Counter Reset Condition Selection (Pn517) set to 0.
9	VZERO input enabled	S, T	Zero Speed Designation (VZERO) is open with Zero Speed Designation Selection (Pn315) set to 1 (enabled).
11	Internal command speed zero	S	The selected internal command speed is 30 r/min or less.
14	Other causes	All	Although none of the above causes 1 to 13 is applicable, the Servomotor is rotating at 20 r/min or less. (Possible causes are a small command value, a heavy load, lock, or collision, a Servo Drive/Servomotor fault, etc.)

Note The Servomotor may rotate even when the displayed cause number is other than 0.

Display of the Number of I/O Signal Changes U18.ct

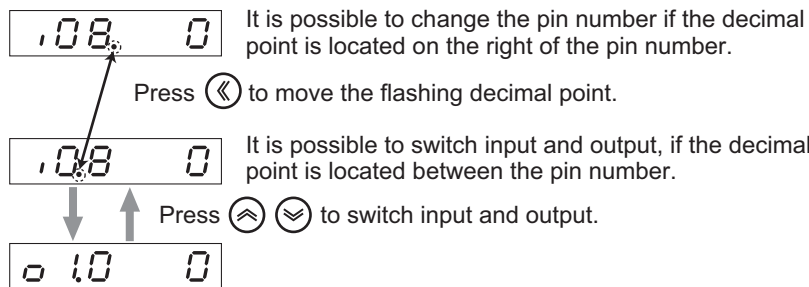
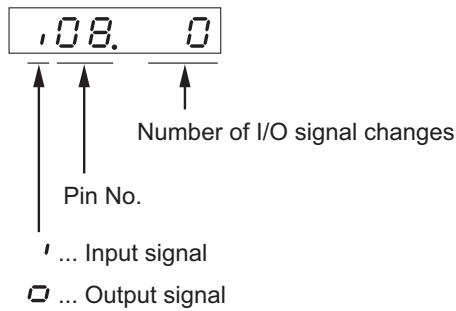

Reserved U20.Ab5

Do not set.

Reserved U21.AE5

Do not set.

Monitor for the Number of Encoder Communications Errors U22.rEc

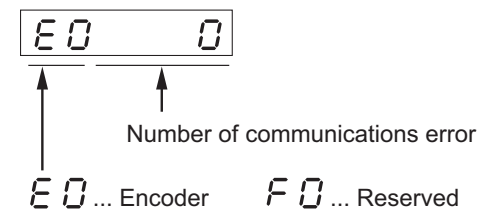

Press \uparrow \downarrow to switch "Encoder" or "Reserved".

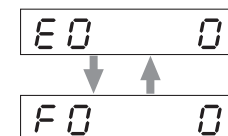

Reserved `U23. id`

Do not set.

Encoder Position Error `U24.PEP``L39025`

↑ Encoder position error [encoder units]

Lower (L)
Higher (H)

Press  to switch Lower (L) and Higher (H).`L39025` ↔ `H 103`**Reserved** `U25.PFE`

Do not set.

Reserved `U26.hyb`

Do not set.

P-N Voltage `U27. Pn``Pn 280`

↑
P-N Voltage [V] is displayed.

Software Version `U28. no``A-1.23`

- This indicates the software version of the Servo Drive. (Display example: Ver. 1.23)

Drive Serial Number U29.A5E



AL0001



Amplifier Serial Number

AL ... Amplifier Serial Number
Lower (L)

AH ... Amplifier Serial Number
Higher (H)

Press   to switch Lower (L) and Higher (H).

Display example: For serial number 09040001

AL0001



AH0904

Motor Serial Number U30.N5E



ML0001



Motor Serial Number

ML ... Motor Serial Number
Lower (L)

MH ... Motor Serial Number
Higher (H)

Press   to switch Lower (L) and Higher (H).

Display example: For serial number 09040001

ML0001



MH0904

Accumulative Operation Time U31 tE

L 2.5

↑ ↑
Accumulative Operation Time [h] is displayed.
Lower (L)
Higher (H)

Press  to switch Lower (L) and Higher (H).

L 2.5 ↔ H

Automatic Motor Recognition Function U32Aud

Aud on Automatic Recognition Enabled

Aud off Automatic Recognition Disabled

Drive Temperature and Encoder Temperature U33Ath

th 28

↑
The temperature [°C] is displayed.

Press   to switch the desired monitor.

Ath 28

↓ ↑
Eth 28

Note The encoder temperature value appears only when an incremental encoder is used.

Reserved U35 SF

Do not set.

8-4-3 Parameter Setting Mode

1 Change to the parameter mode display.

Key operation	Display example	Description
		The display is based on Default Display (Pn528) setting.
		Press key to change to the monitor mode display.
		Press key to change to the parameter setting mode display.

2 Set the parameter number.

Key operation	Display example	Description
 		Use , , and keys to select the desired parameter number. <ul style="list-style-type: none"> Use to move "." to the left and change the digit to set. Use to increase the value of the digit with ".". Use to decrease the value of the digit with ".".



3 Display the parameter setting.

Key operation	Display example	Description
		Use key to display the set value.

4 Change the parameter value.

Key operation	Display example	Description
 		Use , , and keys to change the value. <ul style="list-style-type: none"> Use to move "." to the left and change the digit to set. Use to increase the value of the digit with ".". Use to decrease the value of the digit with ".".
		Press key to save the new set value. <ul style="list-style-type: none"> To cancel the change, press , instead of , to return to the display shown in Step 2.

5 Return to the parameter setting mode display.

Key operation	Display example	Description
		Press  key to return to the parameter setting mode display.











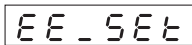

Precautions for Correct Use

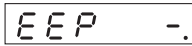
- Some parameters will be displayed with an “r” before the number when the display returns to the parameter setting mode. To enable the set values that are changed for these parameters, you must turn the power supply OFF and ON after saving the parameters to the EEPROM.
- If the Front Panel Parameter Write Selection (Pn617) is set to 1, the parameter set value is automatically written to EEPROM when changed.
- When the set value for a parameter is saved, the new setting will be used for control. Make gradual changes instead of changing the large numbers at once, when changing values for parameters that greatly affect motor operation (speed loop gain, position loop gain, etc. in particular).
- For details about parameters, refer to *Section 7 Parameter Details*.

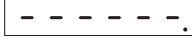

8-4-4 Parameter Write Mode

The following operation must be performed so that set values changed in Parameter Setting Mode are saved to EEPROM.

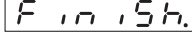
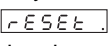
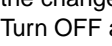
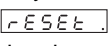
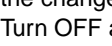
1 Save the changed setting to memory.

Key operation	Display example	Description
		Press  key to switch to the parameter write mode display.
		Press  key to switch to the parameter write mode display.
	  	Press and hold  key for 5 seconds or more (until  appears). The number of dashes on the display increases. The parameter write process starts. (This display appears only momentarily.)
		This indicates a normal completion. Other than this, the following displays may be shown  and  .  also indicates a normal completion, but it means that some of the changed parameters are enabled only after the system is restarted. Turn OFF and then ON the power supply again.  indicates a write alarm. Write the data again.

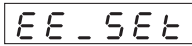
2 Return to the parameter write mode display.

Key operation	Display example	Description
		Press  key to return to the parameter write mode display.



Precautions for Correct Use

- Write the data again if a write alarm occurs. If a write alarm persists, the Servo Drive may be faulty.
- Do not turn OFF the power supply while the Servo Drive is writing to the EEPROM. If the power supply is cut off, incorrect data may be written. In case that this happens, set all the parameters again and retry writing the data.

8-4-5 Auxiliary Function Mode

The auxiliary function mode provides the alarm clear, jog operation, parameter initialization, and front panel lock/unlock functions.

● Change to the auxiliary function mode display.

Key operation	Display example	Description
		The display is based on Default Display (Pn528) setting.
		Press key to change to the monitor mode display.
		Press key three times to change to the auxiliary function mode display.

Alarm Clear

The alarm that occurred can be reset by following the steps below.

Some alarms cannot be reset using this method. For details, refer to *10-3 Alarm List* on page 10-6.

1 Execute the alarm clear function.

Key operation	Display example	Description
		Press key to switch to the alarm clear mode display.
	 	Press and hold key for 5 seconds or more (until appears). The number of dashes on the display increases. The alarm clear process starts.
		This indicates a normal completion. If is displayed, the alarm clear process is not completed. Turn OFF and then ON the power supply again to reset the alarm.

2 Return to the auxiliary function mode display.

Key operation	Display example	Description
		Press key to return to the auxiliary function mode display.









Reserved `Fn_of1` `Fn_of2` `Fn_of3`

Do not set.





Jog Operation

Trial operation can be performed with no-load, i.e., without connecting the control I/O connector (CN1) to the Servomotor.



1 Preparations for jog operation

Key operation	Display example	Description
	<code>Fn_JoG.</code>	From the auxiliary function mode alarm clear display, press the  key to switch to the jog operation mode display.
	<code>JoG -.</code>	Press  key to switch to the jog operation mode display.
	<code>JoG --.</code> <code>-----.</code> <code>rEAdy.</code>	Press and hold  key for 5 seconds or more (until <code>StArT</code> appears). The number of dashes on the display increases. The jog operation is ready. If <code>ErRor</code> is displayed, the servo is not ready.
	<code>rEAdy.</code> <code>r.EAdy</code> <code>SrU_on</code>	Press and hold  key for 5 seconds or more (until <code>StArT</code> appears). The decimal point moves leftward. The servo is turned ON.

2 Perform jog operation.

Key operation	Display example	Description
 	<code>SrU_on</code>	Pressing the  key enables the Servomotor to rotate in the forward direction; pressing the  key enables the Servomotor to rotate in the reverse direction. The Servomotor stops rotating when you release the key. At this time, the rotation speed set in Jog Speed (Pn604) will be used. If <code>ErRor</code> is displayed, the servo is not ready.

3 Return to the auxiliary function mode display.

Key operation	Display example	Description
	<code>Fn_JoG.</code>	Press  key to return to the auxiliary function mode display. The servo is unlocked and in a servo-free state.

**Precautions for Correct Use**

- Before performing jog operation, be sure to disconnect the load from the Servomotor and remove the wires connected to the control I/O connector (CN1).
- To prevent problems such as vibration during jog operation, set the parameter related to gains to correct values. Set Inertia Ratio 1 (Pn004) to 0.
- Job operation is performed in the speed control mode. Configure each setting so that the motor operates correctly in the speed control.
- If the Operation Command (RUN) turns ON during jog operation, the Servo Drive will display `Error` and perform normal operation based on external commands.

Reserved `Fn_EnC`

Do not set.

Parameter Initialization

Use the following procedure to initialize the selected parameter.

1 Initialize the parameter.

Key operation	Display example	Description
	<code>Fn_104</code>	Press key to switch to the parameter initialization mode display.
	<code>101--</code> <code>-----</code> <code>StArt</code>	Press and hold key for 5 seconds or more (until <code>StArt</code> appears). The number of dashes on the display increases. The initialization process for the selected parameter starts.
	<code>FinISH</code>	This indicates a normal completion. If <code>Error</code> is displayed, the parameter is not initialized. Turn OFF the Servo Drive and retry.

2 Return to the auxiliary function mode display.

Key operation	Display example	Description
	<code>AF_EnC</code>	Press key to return to the auxiliary function mode display.





**Precautions for Correct Use**

The parameter cannot be initialized if alarm number 11 (Power Supply Undervoltage), 36 (Parameter Error), or 37 (Parameter Destruction) is displayed.



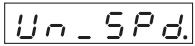





Front Panel Lock

Use the following procedure to lock the front panel.

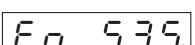

1 Change to the parameter mode display.

Key operation	Display example	Description
		Press  key to change to the monitor mode display.
		Press  key to change to the parameter setting mode display.













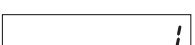

2 Set the parameter number.

Key operation	Display example	Description
  		Use the  ,  , and  keys to select Pn535. <ul style="list-style-type: none"> Use  to move "." to the left and change the digit to set. Use  to increase the value of the digit with ".". Use  to decrease the value of the digit with ".".



3 Display the parameter setting.

Key operation	Display example	Description
		Use  key to display the set value.





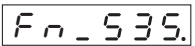





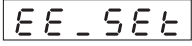

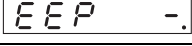

4 Change the parameter value.

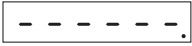
Key operation	Display example	Description
  		Use  ,  , and  keys to change the value. <ul style="list-style-type: none"> Use  to move "." to the left and change the digit to set. Use  to increase the value of the digit with ".". Use  to decrease the value of the digit with ".".
		Press  key to save the new set value. <ul style="list-style-type: none"> To cancel the change, press , instead of , to return to the display shown in Step 2.

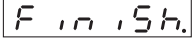

5 Return to the parameter setting mode display.

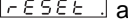
Key operation	Display example	Description
		Press  key to return to the parameter setting mode display.

6 Save the changed setting to memory.

Key operation	Display example	Description
		Press  key to switch to the parameter write mode display.
		Press  key to switch to the parameter write mode display.
	  	Press and hold  key for 5 seconds or more (until  appears). The number of dashes on the display increases. The parameter write process starts. (This display appears only momentarily.)
		This indicates a normal completion. Other than this, the following displays may be shown  and  .  also indicates a normal completion, but it means that some of the changed parameters are enabled only after the system is restarted. Turn OFF and then ON the power supply again.  indicates a write alarm. Write the data again.

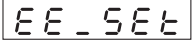
7 Return to the parameter write mode display.

Key operation	Display example	Description
		Press  key to return to the parameter write mode display.

8 Turn OFF and then ON the power supply again.









Precautions for Correct Use

- Items which are limited vary depending on the mode setting.
- If the Front Panel Parameter Write Selection (Pn617) is set to 1, the parameter set value is automatically written to EEPROM when changed.
- For details about the front panel lock function, refer to Front Key Protection Setting (Pn535) in *7-6 Extended Parameters* on page 7-42.



Front Panel Unlock

Use the following procedure to unlock the front panel.

1 Unlock the front panel lock.

Key operation	Display example	Description
	<code>Fn_unL</code>	From the auxiliary function mode alarm reset display, press  key to switch to the front panel lock mode display.
	<code>unL -.</code>	Press  key to switch to the front panel lock mode display.
	<code>unL --.</code> <code>-----.</code> <code>StArt</code>	Press and hold  key for 5 seconds or more (until <code>StArt</code> appears). The number of dashes on the display increases. The front panel has been unlocked.
	<code>Finish.</code>	This indicates a normal completion. If <code>Error</code> is displayed, the front panel is not unlocked. Turn OFF the Servo Drive and retry.

2 Return to the auxiliary function mode display.

Key operation	Display example	Description
	<code>Fn_EnC</code>	Press  key to return to the auxiliary function mode display.

8-5 Trial Operation

When you finished installation, wiring, and switch settings, and confirmed that the status was normal after turning ON the power supply, perform trial operation. The main purpose of trial operation is to confirm that the servo system operates in an electrically correct method.

If an error occurs during trial operation, refer to *Section 10 Troubleshooting and Maintenance* to eliminate the cause. Then check for safety, and retry trial operation.

8-5-1 Preparations for Trial Operation

Inspections before Trial Operation

Check the following items.

- **Wiring**

- Make sure that there are no wiring errors (especially for the power supply input and motor output).
- Make sure that there are no short-circuits. (Check the ground for short circuits as well.)
- Make sure that there are no loose connections.

- **Power Supply Voltage**

- Make sure that the voltage corresponds to the rated voltage.

- **Servomotor Installation**

- Make sure that the Servomotor is securely installed.

- **Disconnection from Mechanical Systems**

- If necessary, make sure that the load is disconnected from mechanical systems.

- **Brake Released**

- Make sure that the brake is released.

8-5-2 Trial Operation in Position Control Mode

- 1** Use the Connector CN1.
- 2** Turn ON the Servo Drive power supply.
- 3** Check the standard parameter values.
- 4** Set Command Pulse Mode Selection (Pn007) to a value that matches the output pattern of the host system.
- 5** Write the parameter data to the EEPROM and turn OFF and then ON the power supply.
- 6** Apply 12 to 24 VDC between the operation command input (RUN: CN1 pin 29) and +24VIN (CN1 pin 7) to turn ON the servo and have the Servomotor excited.
- 7** Input a low-frequency pulse signal from the host device to start low-speed operation.

Check to be sure that the Servomotor rotates at the set speed and stops when the command (pulses) is terminated.

9

Adjustment Functions

This section explains the functions, setting methods, and items to note regarding various gain adjustments.

9-1	Gain Adjustment	9-2
9-1-1	Purpose of the Gain Adjustment	9-2
9-1-2	Gain Adjustment Methods	9-2
9-1-3	Gain Adjustment Procedure	9-3
9-2	Realtime Autotuning	9-4
9-2-1	Setting Realtime Autotuning	9-5
9-2-2	Setting Machine Rigidity	9-5
9-3	Manual Tuning	9-11
9-3-1	Basic Settings	9-11

9-1 Gain Adjustment

OMNUC G5-series (Pulse-train Input Type) Servo Drives provide a realtime autotuning function. With this function, gain adjustments can be made easily even by those who use a servo system for the first time. If you cannot obtain the desired responsiveness with autotuning, use manual tuning.

9-1-1 Purpose of the Gain Adjustment

The Servo Drive must operate the motor in response to commands from the host system with minimal time delay and maximum reliability. The gain is adjusted to bring the actual operation of the motor as close as possible to the operation specified by the commands, and to maximize the performance of the machine.

Example: Ball screw

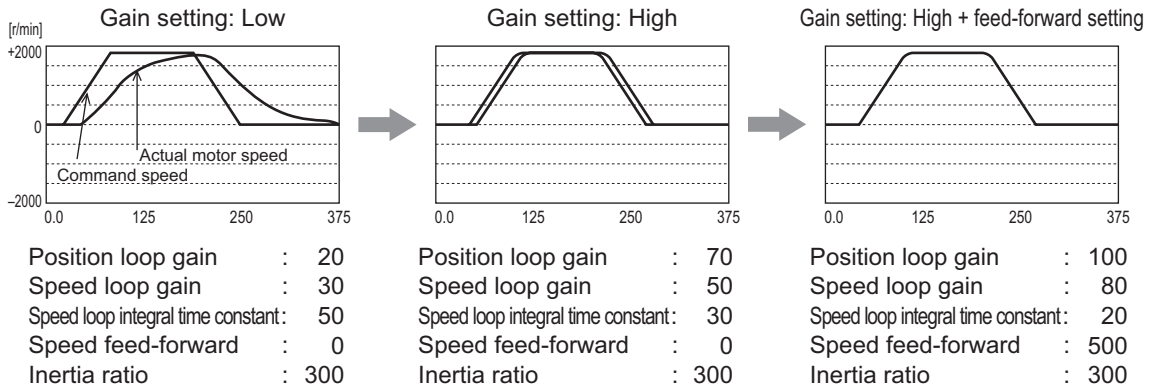

9-1-2 Gain Adjustment Methods

Function		Description	Reference page
Automatic adjustment	Realtime autotuning	Realtime autotuning estimates the load inertia of the machine in realtime and automatically sets the optimal gain according to the estimated load inertia.	P.9-4
Manual adjustment	Manual tuning	Manual adjustment is performed if autotuning cannot be executed due to restrictions on the control mode or load conditions or if ensuring that the maximum responsiveness matching each load is required.	P.9-11
	Basic procedure	Position control mode adjustment	P.9-12
		Internally set speed control mode adjustment	P.9-13

Note 1 Take sufficient measures to ensure safety.

2 If vibration (unusual noise or vibration) occurs, immediately turn OFF the power supply or turn OFF the servo.

9-1-3 Gain Adjustment Procedure

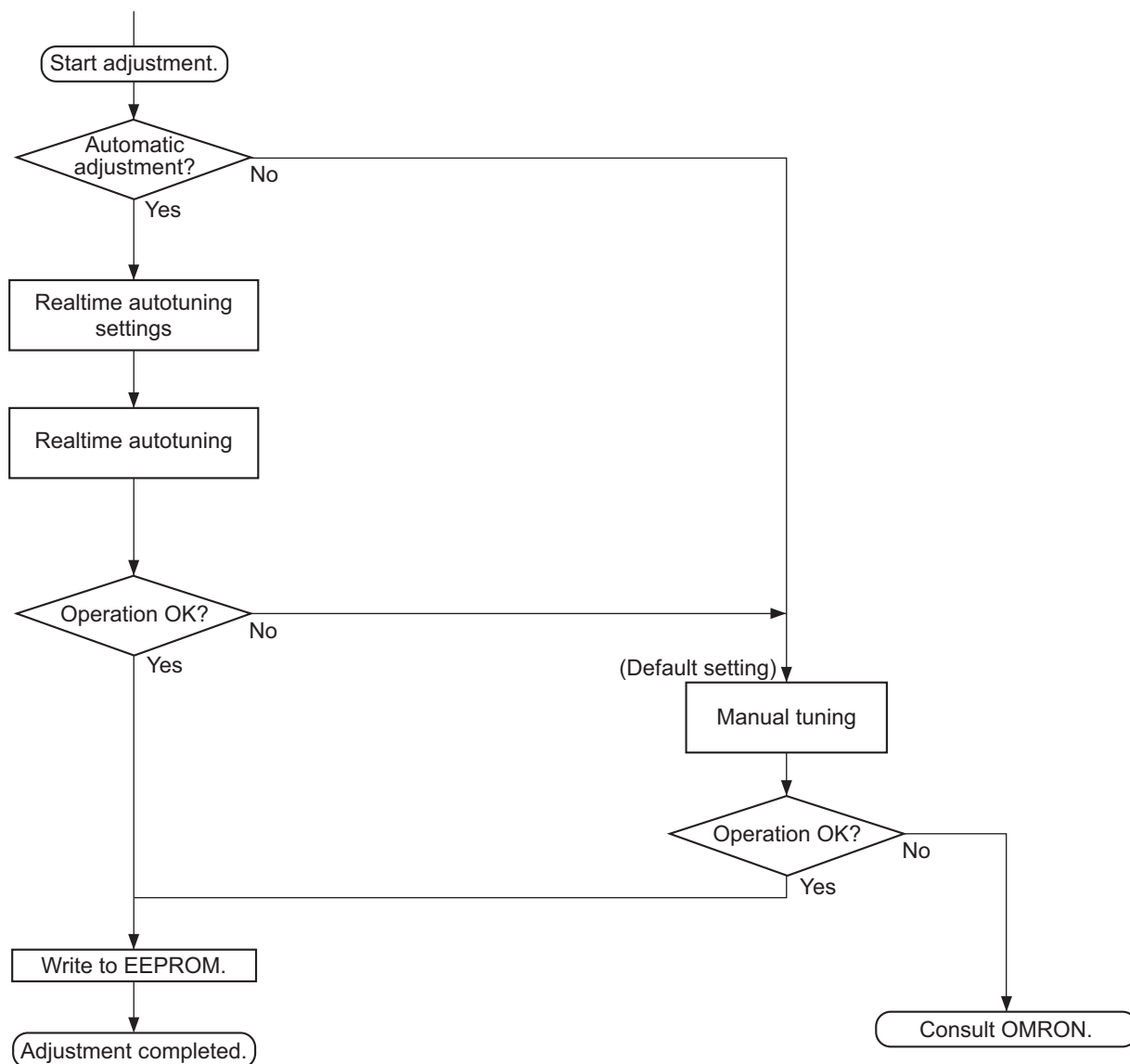

Gain Adjustment and Machine Rigidity

To improve machine rigidity:

- Install the machine on a secure base so that it does not have any play.
- Use couplings that have a high rigidity, and that are designed for servo systems.
- Use a wide timing belt, and use a tension within the range of allowable axial load for the motor or decelerator output.
- Use gears with small backlash.

The specific vibration (resonance frequencies) of mechanical systems has a large impact on the gain adjustment of the servo. The servo system responsiveness cannot be set high for machines with a low resonance frequency (low machine rigidity).

9-2 Realtime Autotuning

Realtime autotuning estimates the load inertia of the machine in realtime, and operates the machine by automatically setting the gain according to the estimated load inertia. At the same time, it can lower the resonance and vibration if the adaptive filter is enabled.

Realtime autotuning is enabled for any control to adjust the speed loop PI control.

Switching to the realtime autotuning is enabled when Switching Mode in Position Control (Pn115) is set to 10 (Combination of command pulse input and motor speed).

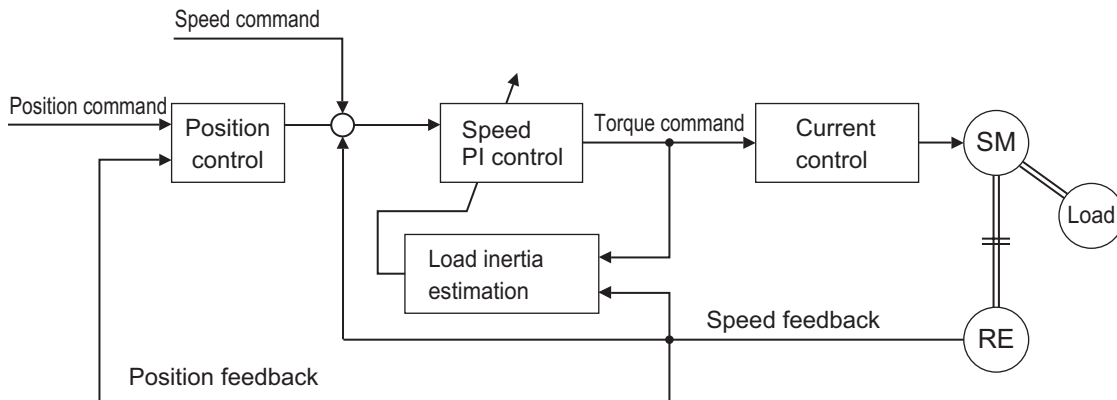

Precautions for Correct Use

- Realtime autotuning may not function properly under the conditions described in the following table. In such cases, use manual tuning.

	Conditions that interfere with the realtime autotuning
Load inertia	<ul style="list-style-type: none"> If the load inertia is too small or too large compared with the rotor inertia (less than 3 times, more than 20 times, or more than the applicable load inertia ratio). If the load inertia changes quickly (in less than 10 s).
Load	<ul style="list-style-type: none"> If the machine rigidity is extremely low. If there is a play, such as a backlash.
Operation pattern	<ul style="list-style-type: none"> If the speed continues at lower than 100 r/min. If the acceleration/deceleration is 2,000 r/min/s or lower. If the acceleration/deceleration torque is too small compared with the unbalanced load and the viscous friction torque. If either a speed of 100 r/min or higher or an acceleration/deceleration of 2,000 r/min/s or higher does not last for 50 ms or more.

- With realtime autotuning, each parameter is fixed to the value in the machine rigidity table at the time the machine rigidity is set. By estimating the load inertia from the operation pattern, the operation coefficient for the speed loop gain and the integral time constant are altered. Doing this for each pattern can cause vibration, so the estimation value is set conservatively.

9-2-1 Setting Realtime Autotuning

1 When setting realtime autotuning, turn the servo OFF.

2 Set Realtime Autotuning Mode Selection (Pn002) depending on the load.

Normally, set this parameter to 1 or 2. Use a setting of 3 or 4 when a vertical axis is used. A setting of 5 is used in combination with a software tool. Do not set the parameter to 5 for normal operation.

Gain switching function is enabled for set values 2 to 6. Setting a value between 2 and 6 sets Switching Mode in Position Control (Pn115) to 10 (Combination of command pulse input and the speed). The gain will be switched according to this switching condition.

For details about setting Switching Mode in Position Control (Pn115), refer to *Gain Switching Setting for Each Control Mode* on page 6-30.

Set value	Realtime autotuning	Description
0	Disabled	Realtime autotuning is disabled.
1	Focus on stability (default setting)	No unbalanced load or friction compensation, nor gain switching.
2	Focus on positioning	Used when there is a small unbalanced load or friction.
3	Vertical axis	Used when unbalanced load is present, i.e., with a vertical axis, etc.
4	Friction compensation and vertical axis	Used when a vertical axis or other unbalanced load is present and when friction is large.
5	Load characteristic estimation	Used only for estimating load characteristics.
6	Customization	Used for customizing the realtime autotuning mode.

9-2-2 Setting Machine Rigidity

1 Set Realtime Autotuning Machine Rigidity Setting (Pn003) according to the table below.

Start from the lower machine rigidity number and check the operation.

Machine configuration and drive method	Realtime Autotuning Machine Rigidity Setting (Pn003)
Ball screw direct coupling	12 to 24
Ball screw and timing belt	8 to 20
Timing belt	4 to 16
Gears, rack and pinion drive	4 to 16
Other machines with low rigidity	1 to 8
Stacker cranes	Perform manual tuning.

2 Turn the servo ON and operate the machine with a normal pattern.

To increase responsiveness, increase the machine rigidity number and check the response. If vibration occurs, enable the adaptive filter and operate the machine. If already enabled, lower the machine rigidity number.

- The adaptive filter can be left enabled when realtime autotuning is disabled after the completion of adjustments.
Even if the adaptive filter is disabled, the set values of notch filters 3 and 4 are held.



Precautions for Correct Use

- After startup, immediately after the first servo ON, or when the value set in Realtime Autotuning Machine Rigidity Setting (Pn003) is increased, unusual noise or vibration may occur until the load inertia is estimated or the adaptive filter stabilizes. This is not an error if it disappears right away. If the unusual noise or vibration, however, continues for three or more reciprocating operations, take the following measures in any order you can.
 - Write the parameters used during normal operation to the EEPROM.
 - Lower the value set in Realtime Autotuning Machine Rigidity Setting (Pn003).
 - Manually set the notch filter.
 - Once unusual noise or vibration occurs, Inertia Ratio 1 (Pn004), Torque Command Value Offset (Pn607), Forward Direction Torque Offset (Pn608), and Reverse Direction Torque Offset (Pn609) may have changed to an extreme value. In this case, also take the measures described above.
 - Out of the results of realtime autotuning, Inertia Ratio 1 (Pn004), Torque Command Value Offset (Pn607), Forward Direction Torque Offset (Pn608), and Reverse Direction Torque Offset (Pn609) are automatically saved to the EEPROM every 30 minutes. Realtime autotuning uses this saved data as the default settings when the power supply is turned ON again.
 - The parameters are automatically set based on Realtime Autotuning Machine Rigidity Setting (Pn003) if realtime autotuning is enabled.
-

● Realtime Autotuning (RTAT) Parameter Table

Parameter No.	Name	Autotuning Machine Rigidity Setting (Pn003)							
		0	1	2	3	4	5	6	7
Pn004	Inertia Ratio 1	Estimated load inertia ratio							
Pn100	Position Loop Gain	20	25	30	40	45	55	75	95
Pn101	Speed Loop Gain	15	20	25	30	35	45	60	75
Pn102	Speed Loop Integral Time Constant	3,700	2,800	2,200	1,900	1,600	1,200	900	700
Pn103	Speed Feedback Filter Time Constant	0	0	0	0	0	0	0	0
Pn104	Torque Command Filter Time Constant	1,500	1,100	900	800	600	500	400	300
Pn105	Position Loop Gain 2	25	30	40	45	55	70	95	120
Pn106	Speed Loop Gain 2	15	20	25	30	35	45	60	75
Pn107	Speed Loop Integral Time Constant 2	10,000	10,000	10,000	10,000	10,000	10,000	10,000	10,000
Pn108	Speed Feedback Filter Time Constant 2	0	0	0	0	0	0	0	0
Pn109	Torque Command Filter Time Constant 2	1,500	1,100	900	800	600	500	400	300
Pn110	Speed Feed-forward Amount	300	300	300	300	300	300	300	300
Pn111	Speed Feed-forward Command Filter	50	50	50	50	50	50	50	50
Pn112	Torque Feed-forward Amount	0	0	0	0	0	0	0	0
Pn113	Torque Feed-forward Command Filter	0	0	0	0	0	0	0	0
Pn114	Gain Switching Input Operating Mode Selection	1	1	1	1	1	1	1	1
Pn115	Switching Mode in Position Control	Gain Switching Enable Mode: 10 Gain Switching Disable Mode: 0							
Pn116	Gain Switching Delay Time in Position Control	30	30	30	30	30	30	30	30
Pn117	Gain Switching Level in Position Control	50	50	50	50	50	50	50	50
Pn118	Gain Switching Hysteresis in Position Control	33	33	33	33	33	33	33	33
Pn119	Position Gain Switching Time	33	33	33	33	33	33	33	33
Pn120	Switching Mode in Speed Control	0	0	0	0	0	0	0	0
Pn121	Gain Switching Delay Time in Speed Control	0	0	0	0	0	0	0	0
Pn122	Gain Switching Level in Speed Control	0	0	0	0	0	0	0	0
Pn123	Gain Switching Hysteresis in Speed Control	0	0	0	0	0	0	0	0
Pn605	Gain 3 Effective Time	0	0	0	0	0	0	0	0
Pn606	Gain 3 Ratio Setting	100	100	100	100	100	100	100	100
Pn607	Torque Command Value Offset	Estimated torque command additional value							
Pn608	Forward Direction Torque Offset	Estimated forward torque compensation value							
Pn609	Reverse Direction Torque Offset	Estimated reverse torque compensation value							
Pn610.0, Pn610.3	Function Expansion Setting	0	0	0	0	0	0	0	0
Pn611	Electric Current Response Setting	100	100	100	100	100	100	100	100
Pn613	Inertia Ratio 2	0	0	0	0	0	0	0	0
Pn623	Disturbance Torque Compensation Gain	0	0	0	0	0	0	0	0
Pn624	Disturbance Observer Filter Setting	0	0	0	0	0	0	0	0

Parameter No.	Name	Autotuning Machine Rigidity Setting (Pn003)							
		8	9	10	11	12	13	14	15
Pn004	Inertia Ratio 1	Estimated load inertia ratio							
Pn100	Position Loop Gain	115	140	175	320	390	480	630	720
Pn101	Speed Loop Gain	90	110	140	180	220	270	350	400
Pn102	Speed Loop Integral Time Constant	600	500	400	310	250	210	160	140
Pn103	Speed Feedback Filter Time Constant	0	0	0	0	0	0	0	0
Pn104	Torque Command Filter Time Constant	300	200	200	126	103	84	65	57
Pn105	Position Loop Gain 2	140	175	220	380	460	570	730	840
Pn106	Speed Loop Gain 2	90	110	140	180	220	270	350	400
Pn107	Speed Loop Integral Time Constant 2	10,000	10,000	10,000	10,000	10,000	10,000	10,000	10,000
Pn108	Speed Feedback Filter Time Constant 2	0	0	0	0	0	0	0	0
Pn109	Torque Command Filter Time Constant 2	300	200	200	126	103	84	65	57
Pn110	Speed Feed-forward Amount	300	300	300	300	300	300	300	300
Pn111	Speed Feed-forward Command Filter	50	50	50	50	50	50	50	50
Pn112	Torque Feed-forward Amount	0	0	0	0	0	0	0	0
Pn113	Torque Feed-forward Command Filter	0	0	0	0	0	0	0	0
Pn114	Gain Switching Input Operating Mode Selection	1	1	1	1	1	1	1	1
Pn115	Switching Mode in Position Control	Gain Switching Enable Mode: 10 Gain Switching Disable Mode: 0							
Pn116	Gain Switching Delay Time in Position Control	30	30	30	30	30	30	30	30
Pn117	Gain Switching Level in Position Control	50	50	50	50	50	50	50	50
Pn118	Gain Switching Hysteresis in Position Control	33	33	33	33	33	33	33	33
Pn119	Position Gain Switching Time	33	33	33	33	33	33	33	33
Pn120	Switching Mode in Speed Control	0	0	0	0	0	0	0	0
Pn121	Gain Switching Delay Time in Speed Control	0	0	0	0	0	0	0	0
Pn122	Gain Switching Level in Speed Control	0	0	0	0	0	0	0	0
Pn123	Gain Switching Hysteresis in Speed Control	0	0	0	0	0	0	0	0
Pn605	Gain 3 Effective Time	0	0	0	0	0	0	0	0
Pn606	Gain 3 Ratio Setting	100	100	100	100	100	100	100	100
Pn607	Torque Command Value Offset	Estimated torque command additional value							
Pn608	Forward Direction Torque Offset	Estimated forward torque compensation value							
Pn609	Reverse Direction Torque Offset	Estimated reverse torque compensation value							
Pn610.0, Pn610.3	Function Expansion Setting	0	0	0	0	0	0	0	0
Pn611	Electric Current Response Setting	100	100	100	100	100	100	100	100
Pn613	Inertia Ratio 2	0	0	0	0	0	0	0	0
Pn623	Disturbance Torque Compensation Gain	0	0	0	0	0	0	0	0
Pn624	Disturbance Observer Filter Setting	0	0	0	0	0	0	0	0

Parameter No..	Name	Autotuning Machine Rigidity Setting (Pn003)							
		16	17	18	19	20	21	22	23
Pn004	Inertia Ratio 1	Estimated load inertia ratio							
Pn100	Position Loop Gain	900	1,080	1,350	1,620	2,060	2,510	3,050	3,770
Pn101	Speed Loop Gain	500	600	750	900	1,150	1,400	1,700	2,100
Pn102	Speed Loop Integral Time Constant	120	110	90	80	70	60	50	40
Pn103	Speed Feedback Filter Time Constant	0	0	0	0	0	0	0	0
Pn104	Torque Command Filter Time Constant	45	38	30	25	20	16	13	11
Pn105	Position Loop Gain 2	1,050	1,260	1,570	1,880	2,410	2,930	3,560	4,400
Pn106	Speed Loop Gain 2	500	600	750	900	1,150	1,400	1,700	2,100
Pn107	Speed Loop Integral Time Constant 2	10,000	10,000	10,000	10,000	10,000	10,000	10,000	10,000
Pn108	Speed Feedback Filter Time Constant 2	0	0	0	0	0	0	0	0
Pn109	Torque Command Filter Time Constant 2	45	38	30	25	20	16	13	11
Pn110	Speed Feed-forward Amount	300	300	300	300	300	300	300	300
Pn111	Speed Feed-forward Command Filter	50	50	50	50	50	50	50	50
Pn112	Torque Feed-forward Amount	0	0	0	0	0	0	0	0
Pn113	Torque Feed-forward Command Filter	0	0	0	0	0	0	0	0
Pn114	Gain Switching Input Operating Mode Selection	1	1	1	1	1	1	1	1
Pn115	Switching Mode in Position Control	Gain Switching Enable Mode: 10 Gain Switching Disable Mode: 0							
Pn116	Gain Switching Delay Time in Position Control	30	30	30	30	30	30	30	30
Pn117	Gain Switching Level in Position Control	50	50	50	50	50	50	50	50
Pn118	Gain Switching Hysteresis in Position Control	33	33	33	33	33	33	33	33
Pn119	Position Gain Switching Time	33	33	33	33	33	33	33	33
Pn120	Switching Mode in Speed Control	0	0	0	0	0	0	0	0
Pn121	Gain Switching Delay Time in Speed Control	0	0	0	0	0	0	0	0
Pn122	Gain Switching Level in Speed Control	0	0	0	0	0	0	0	0
Pn123	Gain Switching Hysteresis in Speed Control	0	0	0	0	0	0	0	0
Pn605	Gain 3 Effective Time	0	0	0	0	0	0	0	0
Pn606	Gain 3 Ratio Setting	100	100	100	100	100	100	100	100
Pn607	Torque Command Value Offset	Estimated torque command additional value							
Pn608	Forward Direction Torque Offset	Estimated forward torque compensation value							
Pn609	Reverse Direction Torque Offset	Estimated reverse torque compensation value							
Pn610.0, Pn610.3	Function Expansion Setting	0	0	0	0	0	0	0	0
Pn611	Electric Current Response Setting	100	100	100	100	100	100	100	100
Pn613	Inertia Ratio 2	0	0	0	0	0	0	0	0
Pn623	Disturbance Torque Compensation Gain	0	0	0	0	0	0	0	0
Pn624	Disturbance Observer Filter Setting	0	0	0	0	0	0	0	0

Parameter No.	Name	Autotuning Machine Rigidity Setting (Pn003)							
		24	25	26	27	28	29	30	31
Pn004	Inertia Ratio 1	Estimated load inertia ratio							
Pn100	Position Loop Gain	4,490	5,000	5,600	6,100	6,600	7,200	8,100	9,000
Pn101	Speed Loop Gain	2,500	2,800	3,100	3,400	3,700	4,000	4,500	5,000
Pn102	Speed Loop Integral Time Constant	40	35	30	30	25	25	20	20
Pn103	Speed Feedback Filter Time Constant	0	0	0	0	0	0	0	0
Pn104	Torque Command Filter Time Constant	9	8	7	7	6	6	5	5
Pn105	Position Loop Gain 2	5,240	5,900	6,500	7,100	7,700	8,400	9,400	10,500
Pn106	Speed Loop Gain 2	2,500	2,800	3,100	3,400	3,700	4,000	4,500	5,000
Pn107	Speed Loop Integral Time Constant 2	10,000	10,000	10,000	10,000	10,000	10,000	10,000	10,000
Pn108	Speed Feedback Filter Time Constant 2	0	0	0	0	0	0	0	0
Pn109	Torque Command Filter Time Constant 2	9	8	7	7	6	6	5	5
Pn110	Speed Feed-forward Amount	300	300	300	300	300	300	300	300
Pn111	Speed Feed-forward Command Filter	50	50	50	50	50	50	50	50
Pn112	Torque Feed-forward Amount	0	0	0	0	0	0	0	0
Pn113	Torque Feed-forward Command Filter	0	0	0	0	0	0	0	0
Pn114	Gain Switching Input Operating Mode Selection	1	1	1	1	1	1	1	1
Pn115	Switching Mode in Position Control	Gain Switching Enable Mode: 10 Gain Switching Disable Mode: 0							
Pn116	Gain Switching Delay Time in Position Control	30	30	30	30	30	30	30	30
Pn117	Gain Switching Level in Position Control	50	50	50	50	50	50	50	50
Pn118	Gain Switching Hysteresis in Position Control	33	33	33	33	33	33	33	33
Pn119	Position Gain Switching Time	33	33	33	33	33	33	33	33
Pn120	Switching Mode in Speed Control	0	0	0	0	0	0	0	0
Pn121	Gain Switching Delay Time in Speed Control	0	0	0	0	0	0	0	0
Pn122	Gain Switching Level in Speed Control	0	0	0	0	0	0	0	0
Pn123	Gain Switching Hysteresis in Speed Control	0	0	0	0	0	0	0	0
Pn605	Gain 3 Effective Time	0	0	0	0	0	0	0	0
Pn606	Gain 3 Ratio Setting	100	100	100	100	100	100	100	100
Pn607	Torque Command Value Offset	Estimated torque command additional value							
Pn608	Forward Direction Torque Offset	Estimated forward torque compensation value							
Pn609	Reverse Direction Torque Offset	Estimated reverse torque compensation value							
Pn610.0, Pn610.3	Function Expansion Setting	0	0	0	0	0	0	0	0
Pn611	Electric Current Response Setting	100	100	100	100	100	100	100	100
Pn613	Inertia Ratio 2	0	0	0	0	0	0	0	0
Pn623	Disturbance Torque Compensation Gain	0	0	0	0	0	0	0	0
Pn624	Disturbance Observer Filter Setting	0	0	0	0	0	0	0	0

- The parameters Pn103, Pn108, Pn110 to Pn123, Pn605, Pn606, Pn610, Pn611, Pn613, Pn623, and Pn624 are set to fixed values.

9-3 Manual Tuning

9-3-1 Basic Settings

As described before, the OMNUC G5-series Servo Drives (Pulse-train Input Type) have a realtime autotuning function. Readjustment, however, is required if realtime autotuning cannot adjust the gain properly for some reasons: there is a restriction by load conditions, or a necessity to ensure optimum responsiveness and stability for each load.

This section describes how to perform manual tuning for each mode and function.

Before Manual Setting

More reliable adjustment can be performed quickly by using waveform monitoring with the data tracing function of CX-Drive or by measuring the analog voltage waveform with the monitor function.

● Analog Monitor Output

The actual motor speed, command speed, torque, and accumulated pulses can be measured in the analog voltage level using an oscilloscope or other device. The type of signal to output and the output voltage level are set in Analog Monitor 1 Selection (Pn416) and Analog Monitor 2 Selection (Pn418). For details, refer to *A-2 Parameter List* on page A-11.

● CX-Drive Data Tracing Function

Commands to the motor and motor operation (speed and position error) can be displayed on a computer as waveforms. Refer to the CX-Drive Operation Manual (Cat. No. W453).

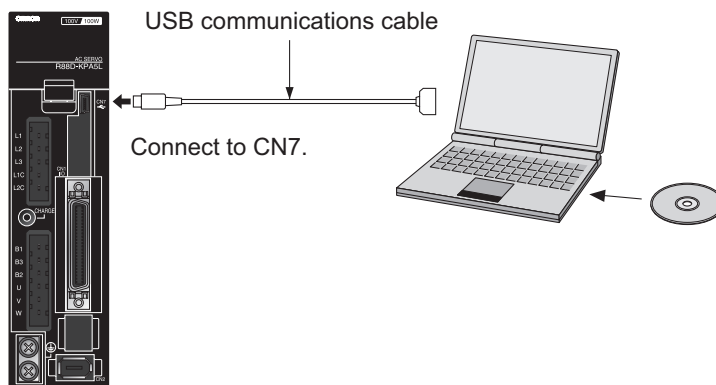

Position Control Mode Adjustment

Use the following procedure to perform the adjustment in position control for the OMNUC G5-series Servo Drive (Pulse-train Input Type).

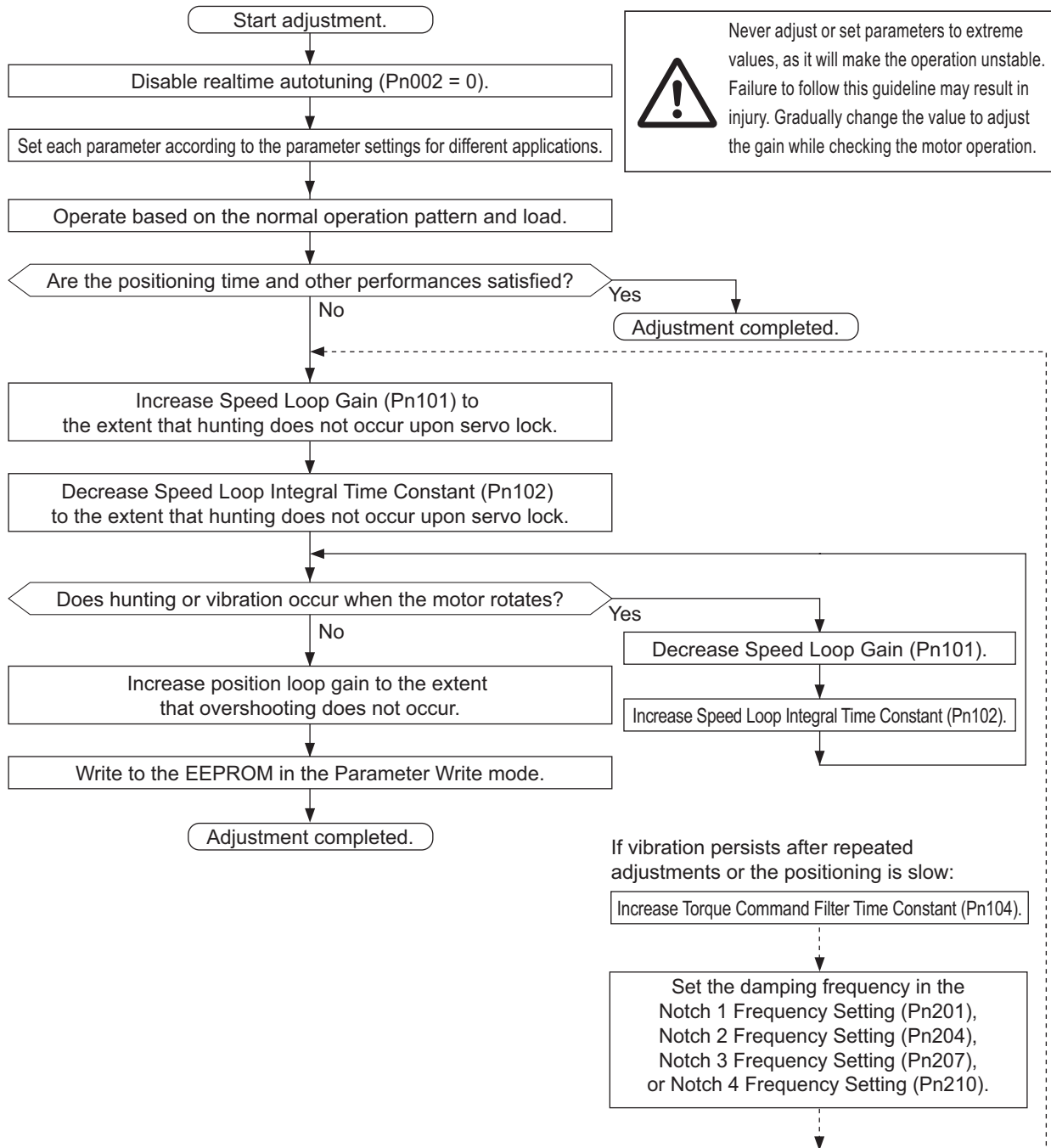

Internally Set Speed Control Mode Adjustment

The speed control adjustment procedure for OMNUC G5-series Servo Drives (Pulse-train Input Type) is similar to the position control mode adjustment procedure. Use the following adjustment procedure.

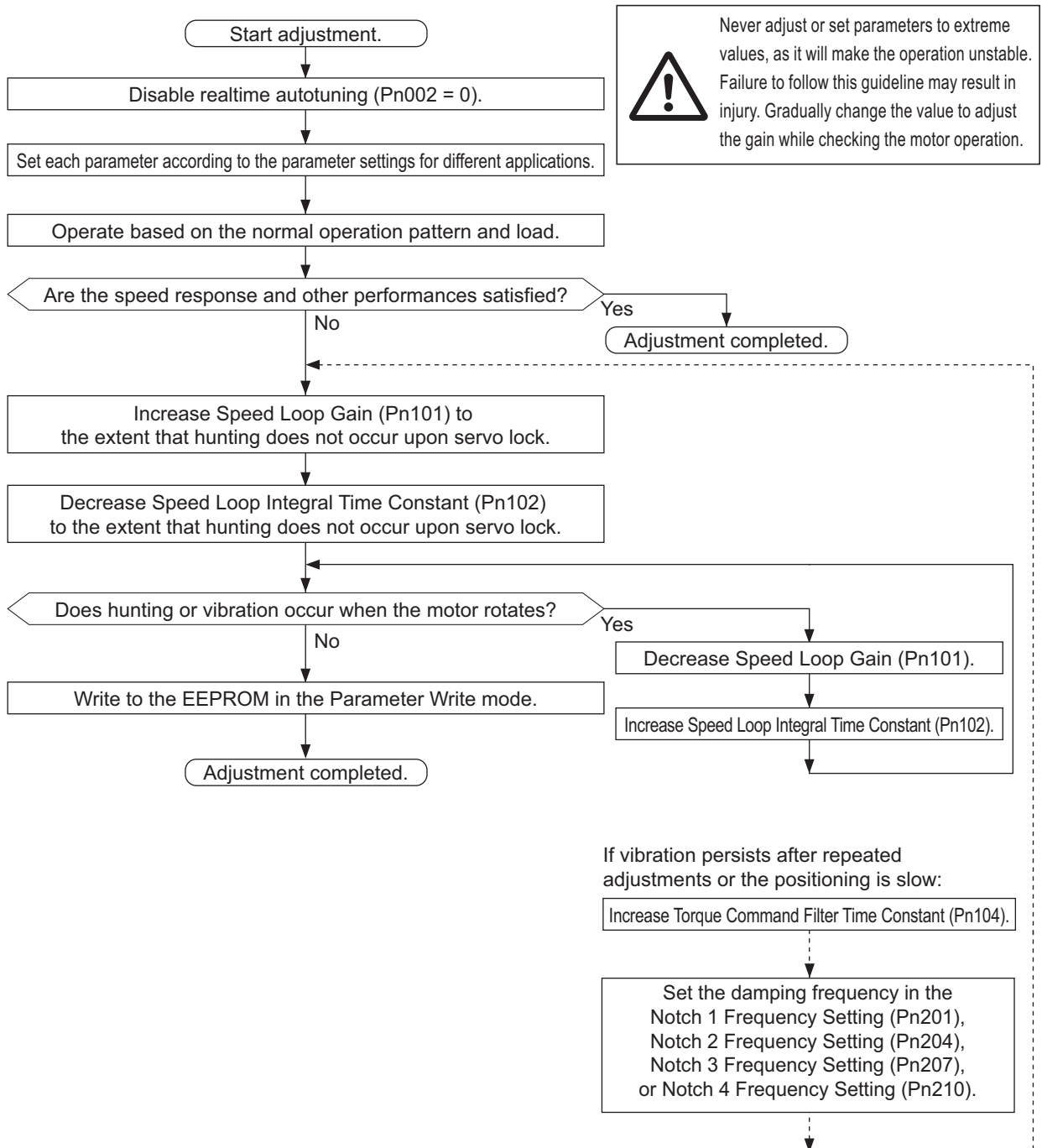

Servo Manual Tuning Method

There are four basic servo adjustment parameters as shown in the table below.

If the intended operation characteristics are obtained by adjusting the following 4 parameters, the adjustments of other parameters are not necessary.

Parameter No.	Name	Default value	2nd parameter No.
Pn100	Position Loop Gain	48.0 [1/s]	Pn105
Pn101	Speed Loop Gain	27.0 Hz	Pn106
Pn102	Speed Loop Integral Time Constant	21.0 ms	Pn107
Pn104	Torque Command Filter Time Constant	0.84 ms	Pn109

Adjustment of Each Parameter

The servo control loop consists of, from the outside, the position loop, the speed loop, and the current loop in this order.

An inner loop is influenced by outer loops and an outer loop is influenced by inner loops, respectively.

Determine the initial value for each parameter based on the machine configuration and rigidity, inertia ratio, and other aspects.

Use the following table as a guide to determine the parameter settings for each application.

● Parameter Settings for Each Application

Application name	Inertia	Rigidity	Position Loop Gain [1/s]	Speed Loop Gain [Hz]	Speed Loop Integral Time Constant	Torque Command Filter Time Constant [× 0.01 ms]
Ball Screw Horizontal	Large	Low	20	140	35	160
Ball Screw Horizontal	Medium	Medium	40	80	20	100
Ball Screw Horizontal	Small	High	80	60	15	80
Ball Screw Vertical	Large	Low	20	160	45	160
Ball Screw Vertical	Medium	Medium	40	80	30	120
Ball Screw Vertical	Small	High	60	60	20	100
Ball Screw Nut Rotation Horizontal	Large	Low	20	140	40	160
Ball Screw Nut Rotation Horizontal	Medium	Medium	40	100	30	120
Ball Screw Nut Rotation Vertical	Large	Low	20	160	45	160
Ball Screw Nut Rotation Vertical	Medium	Medium	40	120	25	120
Timing Belt	Large	Low	20	160	60	160
Timing Belt	Medium	Medium	30	120	40	120
Rack and Pinion	Large	Low	20	160	60	160
Rack and Pinion	Large	Medium	30	120	40	120
Rack and Pinion	Medium	Medium	40	100	20	100
Index Table	Large	Medium	40	120	25	120
Index Table	Small	High	80	120	20	100
Robot Arm Cylindrical	Large	Low	15	160	60	160
Robot Arm Cylindrical	Medium	Medium	25	120	40	120
Other General Uses	Medium	Medium	30	100	30	150

- The above values assume that Inertia Ratio 1 (Pn004) is fixed to 300%.

Inertia Guideline

Inertia is small	5 times the rotor inertia max.
Inertia is medium	5 to 10 times the rotor inertia max.
Inertia is large	10 to 20 times the rotor inertia max.

● Position Loop Gain (Pn100, 105)

This loop controls the number of pulses from encoder to be the designated number of pulses.

This is called an error counter, and when the pulse is equal to or lower than the specified value, positioning is completed and the signal is output. The ratio of set maximum speed and error counter is called a position loop gain.

$$\text{Position loop gain [1/s]} = \frac{\text{Maximum command speed [pps]}}{\text{Error counter accumulated pulse (P)}}$$

For the position loop gain, set the inverse of the value set in Speed Loop Integral Time Constant (Pn102) as a guide. This is 10 [1/s] when Pn102 is set to 100 ms.

With this setting, overshooting never occurs. For quicker positioning, increase the position loop gain value. Note that setting an excessively large results in overshooting or vibration. If this occurs, decrease the set value.

If the speed loop or the current loop is the cause of vibration, adjusting the position loop is not a solution for eliminating vibration.

Response to the position loop gain adjustment is as shown below.

- If the position loop gain is high, overshooting occurs.

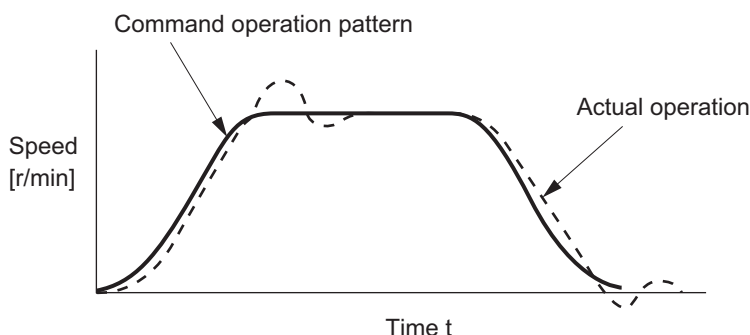

- If the position loop gain is low, positioning completion speed becomes slow.

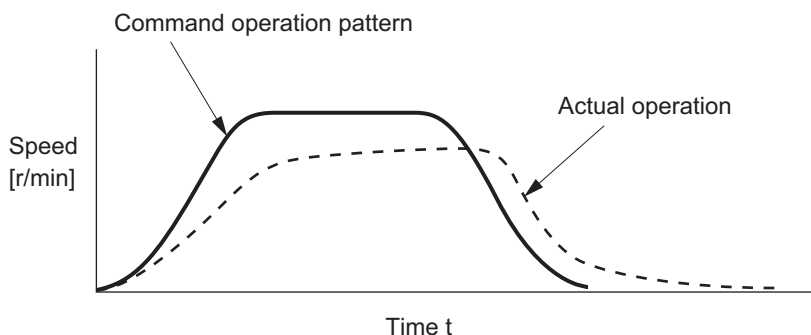

● Speed Loop Gain (Pn101, Pn106)

The speed loop gain determines the responsiveness of a Servo Drive.

When Inertia Ratio 1 (Pn004) is set correctly, the values set in these parameters are the response frequency.

Increasing the value of the speed loop gain improves the responsiveness and quickens positioning, but vibration is more likely to occur. Adjustment must be made so that vibration does not occur.

This parameter is related to Speed Loop Integral Time Constant (Pn102), so it is possible to increase the speed loop gain by increasing the integral time constant.

- If the speed loop gain is low, the speed response becomes slow and a large overshooting occurs. In such case, increase the speed loop gain.

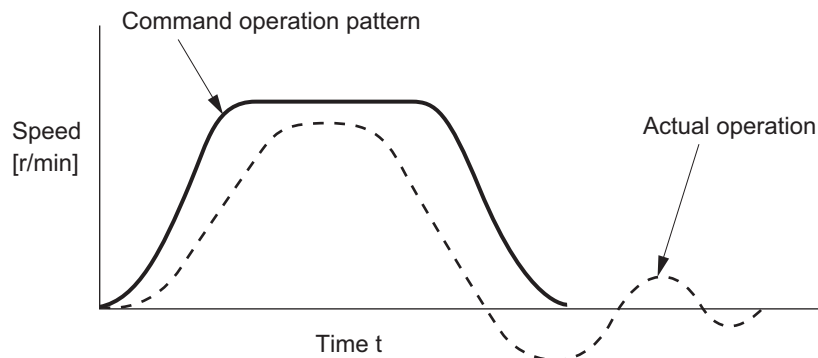

- If the speed loop gain is high, vibrations are more likely to occur. Vibration or resonance may not disappear. In such case, decrease the speed loop gain.

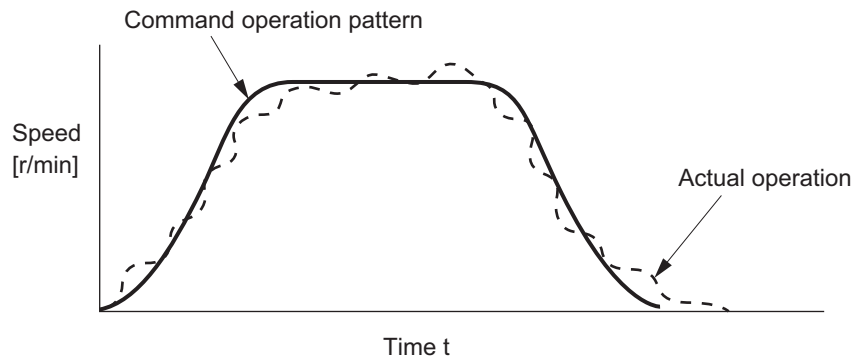

● Speed Loop Integral Time Constant (Pn102, 107)

The speed loop integral time constant also determines the responsiveness of a Servo Drive.

- If the speed loop integral time constant is low, vibration or resonance occurs.
In such case, increase the speed loop integral time constant.

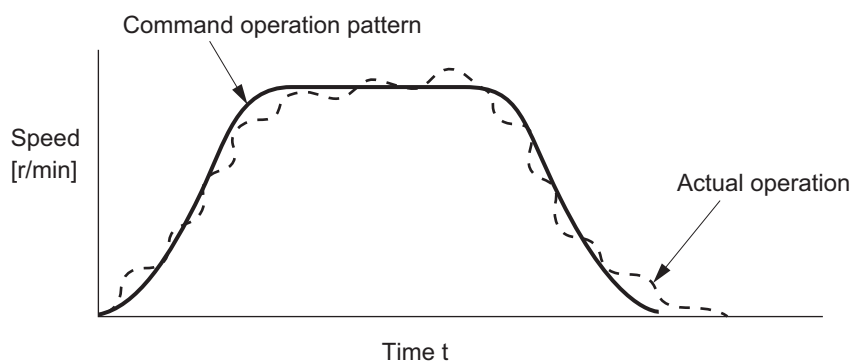

- If the speed loop integral time constant is high, the response is delayed. The servo rigidity becomes weak.
In such case, decrease the speed loop integral time constant.

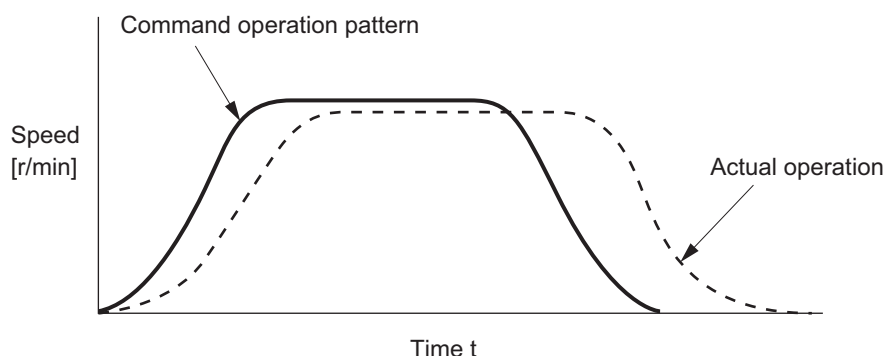

● Torque Command Filter Time Constant (Pn104, 109) for Current Loop Input Adjustment

The torque command filter function applies a filter that smoothens the current command from the speed loop. This ensures a smooth current flow and reduced vibration.

Torque Command Filter Time Constant is set to 84 (0.84 ms) by default.

Increase the value to decrease vibration. However, increasing the value results in slower response. Set the value to approximately 1/25 of the value set in Speed Loop Integral Time Constant (Pn102). The torque command filter also reduces vibration due to the machine rigidity.

This parameter is related to Speed Loop Gain (Pn101), so increasing the Torque Command Filter Time Constant value does not reduce vibration if the value set in Pn101 is too large.

If the Servomotor is subject to mechanical resonance with ball screws or other parts, use the notch filter parameters Pn201, Pn204, Pn207, and Pn210, or enable the adaptive filter to reduce the vibration.

● Other Adjustments

Overshooting may appear in the speed response if a torque loop is saturated due to reasons such as a short acceleration time and a large load torque. If overshooting occurs, increase the acceleration time to prevent saturation of the torque loop.

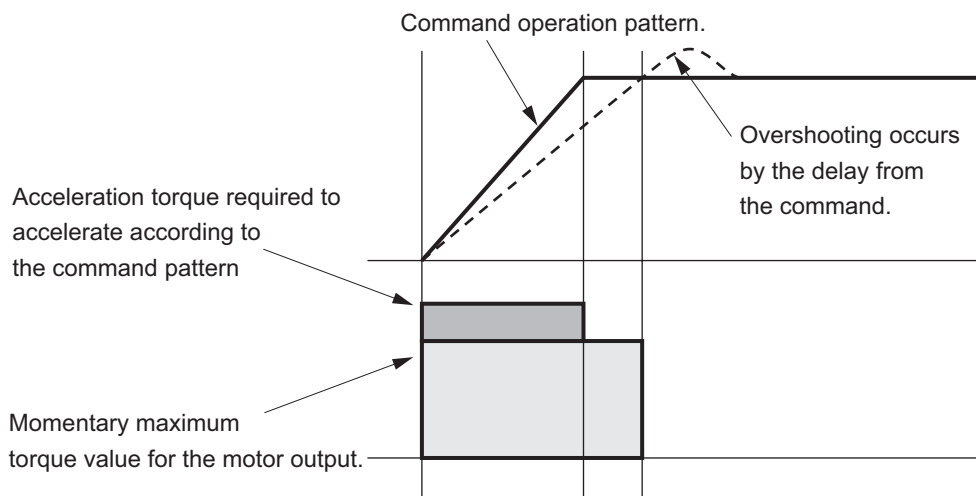

Troubleshooting and Maintenance

This section explains the items that must be checked when problems occur, error diagnosis using the alarm LED display and measures, error diagnosis based on the operating condition and measures, and periodic maintenance.

10-1 Actions for Problems	10-2
10-1-1 Preliminary Checks When a Problem Occurs.....	10-2
10-1-2 Precautions When a Problem Occurs.....	10-3
10-1-3 Replacing the Servomotor or Servo Drive	10-4
10-2 Warning List	10-5
10-3 Alarm List	10-6
10-4 Troubleshooting	10-10
10-4-1 Error Diagnosis with Alarm Displays.....	10-10
10-4-2 Error Diagnosis Using the Operation State.....	10-17
10-5 Periodic Maintenance	10-21
10-5-1 Servomotor Life Expectancy.....	10-21
10-5-2 Servo Drive Life Expectancy.....	10-22

10-1 Actions for Problems

10-1-1 Preliminary Checks When a Problem Occurs

This section explains the preliminary checks and analytical software required to determine the cause of a problem if one occurs.

Checking the Power Supply Voltage

- Check the voltage at the power supply input terminals.

Main Circuit Power Supply Input Terminals (L1, L2, L3)

R88D-KP□H (100 W to 1.5 kW): Single-phase 200 to 240 VAC (170 to 264 VAC) 50/60 Hz
 (750 W to 1.5 kW): 3-phase 200 to 240 VAC (170 to 264 VAC) 50/60 Hz
 (2 to 5 kW): 3-phase 200 to 230 VAC (170 to 253 VAC) 50/60 Hz

Control Circuit Power Supply Input Terminals (L1C, L2C)

R88D-KP□H (100 to 1.5 kW): Single-phase 200 to 240 VAC (170 to 264 VAC) 50/60 Hz
 (2 to 5 kW): Single-phase 200 to 230 VAC (170 to 253 VAC) 50/60 Hz

If the voltage is out of range, there is a risk of operation failure. Be sure that the power supply is within the specified range.

- Check the voltage of the sequence input power supply (+24 VIN terminal (CN1 pin 7)).

It must be between 11 and 25 VDC.

If the voltage is out of range, there is a risk of operation failure. Be sure that the power supply is within the specified range.

Checking Whether an Alarm Has Occurred

- Make an analysis using the 7-segment display and operation keys on the front of the Servo Drive.
- When an alarm has occurred
Check the alarm display (□□) and make an analysis based on the alarm that is indicated.
- When an alarm has not occurred
Make an analysis according to the error conditions.
- In either case, refer to *10-4 Troubleshooting* on page 10-10 for details.

10-1-2 Precautions When a Problem Occurs

When checking and verifying I/O after a problem has occurred, the Servo Drive may suddenly start to operate or suddenly stop, so always take the following precautions.

You should assume that anything not described in this manual is not possible with this product.

Precautions

- Disconnect the wiring before checking for cable breakage. If you test conduction with the cable connected, test results may not be accurate due to conduction via bypassing circuit.
- If the encoder signal is lost, the motor may run away, or an alarm may occur. Be sure to disconnect the motor from mechanical systems before checking the encoder signal.
- When measuring the encoder output, perform the measurement based on the SGGND (CN1 pin 13). When an oscilloscope is used for measurement, it will not be affected by noise if measurements are performed using the differential between CH1 and CH2.
- When performing tests, first check that there are no persons in the vicinity of the equipment, and that the equipment will not be damaged even if the motor runs away. Before performing the tests, verify that you can immediately stop the machine using an immediate stop in case the machine runs out of control.

10-1-3 Replacing the Servomotor or Servo Drive

Use the following procedure to replace the Servomotor or Servo Drive.

Replacing the Servomotor

- 1** Replace the motor.
- 2** Perform origin adjustment (for position control).
 - When the motor is replaced, the motor's origin position (phase Z) may deviate, so origin adjustment must be performed.
 - Refer to the position controller's manual for details on performing origin adjustment.

Replacing the Servo Drive

- 1** Take a record of all parameter settings.

Use the operation keys on the Servo Drive to write down all the contents of parameter settings.
- 2** Replace the Servo Drive.
- 3** Set the parameters.

Use the operation keys on the Servo Drive to set all of the parameters.

10-2 Warning List

The warning function outputs a warning signal and notifies state such as an overload before activation of a protective function.

Set what types of warning you want the Servo Drive to output in Warning Output Selection 1 (Pn440) and Warning Output Selection 2 (Pn441).



Precautions for Correct Use

You will be brought to the state before the occurrence of the warning automatically after recovery from the error condition. However, the warning state will be retained during the time period set in Warning Latch Hold Time Selection (Pn627). To clear the warning state before the latch hold time expires, follow a similar procedure as you do when clearing an alarm.

Warning List

Warning No.	Warning name	Latch ^{*1}	Warning condition	Warning Output Selection (Pn440, Pn441) ^{*2}	Warning Mask Setting (Pn638)
A0	Overload Warning	√	The load ratio is 85% or more of the protection level.	1	bit 7
A1	Excessive Regeneration Warning	√	The regeneration load ratio is 85% or more of the level.	2	bit 5
A2	Battery Warning	Fixed to no time limit	The battery voltage is 3.2 V or less.	3	bit 0
A3	Fan Warning	√	The fan stop state continues for 1 second.	4	bit 6
A4	Encoder Communications Warning	√	The encoder communications errors occurred in series more frequently than the specified value.	5	bit 4
A5	Encoder Overheating Warning	√	The encoder temperature exceeded the specified value.	6	bit 3
A6	Vibration Detection Warning	√	Vibrating is detected.	7	bit 9
A7	Life Expectancy Warning	Fixed to no time limit	The life expectancy of the capacitor or the fan is equal to or less than the specified value.	8	bit 2

*1 The "√" fields can be set to 1 to 10 s in Warning Latch Hold Time Selection (Pn627) or to no time limit. However, the battery warning is fixed to no time limit.

*2 Select the types of warning to be output from Warning Output 1 (WARN1) and Warning Output 2 (WARN2) in Warning Output Selection 1 (Pn440) and Warning Output Selection 2 (Pn441). If you set these parameters to 0, all warning types will be output. Do not set other values not listed above.

*3 Each warning detection can be masked by Warning Mask Setting (Pn638). The bit corresponding to each warning is shown in the table above. When the bit is set to 1, the warning detection is masked.

10-3 Alarm List

If the Servo Drive detects an error, it outputs an alarm (ALM), turns OFF the power drive circuit, and displays the corresponding alarm code.



Precautions for Correct Use

- Refer to *10-4-1 Error Diagnosis with Alarm Displays* on page 10-10 for appropriate alarm measures.
- Reset the alarm using one of the following methods. Be sure to remove the cause of the alarm first.
 - Input the Alarm Reset Input (RESET) signal.
 - Turn OFF the power supply, then turn it ON again.
 - Reset the alarm from the CX-Drive.

However, some alarms can only be reset by turning the power supply OFF and ON. Refer to Alarm List on the next page.

- Resetting the alarm is dangerous when the Operation Command (RUN) is ON because the Servomotor will start operating immediately when the alarm is reset. Turn OFF the RUN before resetting the alarm.
In situations where the RUN is always ON, ensure the safety sufficiently before resetting the alarm.
-

Alarm List

Alarm No.		Error detection function	Description and error cause	Attribute		
Main	Sub			History	Can be cleared	Immediate stop ^{*1}
11	0	Control Power Supply Undervoltage	The DC voltage of the main circuit fell below the specified value.	–	√	–
12	0	Overvoltage	The DC voltage in the main circuit is abnormally high.	√	√	–
13	0	Main Power Supply Undervoltage (insufficient voltage between P and N)	The DC voltage of the main circuit is low.	–	√	–
	1	Main Power Supply Undervoltage (AC cutoff detection)	A location was detected where the main circuit AC power supply is cut off.	–	√	–
14	0	Overcurrent	Overcurrent flowed to the IGBT.	√	–	–
	1	IPM Error	Motor power line ground fault or short circuit.	√	–	–
15	0	Servo Drive Overheat	The temperature of the Servo Drive radiator exceeded the specified value.	√	–	√
16	0	Overload	Operation was performed with torque significantly exceeding the rating for several seconds to several tens of seconds.	√	√	–
18	0	Regeneration Overload	The regenerative energy exceeds the processing capacity of the Regeneration Resistor.	√	–	√
	1	Regeneration Tr Error	An error was detected in a Servo Drive regeneration drive Tr.	√	–	–
21	0	Encoder Communications Disconnection Error	The encoder wiring is disconnected.	√	–	–
	1	Encoder Communications Error	An encoder communications error was detected.	√	–	–
23	0	Encoder Communications Data Error	Communications cannot be performed between the encoder and the Servo Drive.	√	–	–
24	0	Error Counter Overflow	The error counter accumulated pulse exceeds the set value for the Error Counter Overflow Level (Pn014).	√	√	√
	1	Excessive Speed error	The difference between the internal position command speed and the actual speed (i.e., the speed error) exceeded the Excessive Speed Error Setting (Pn602).	√	√	√
26	0	Overspeed	The motor rotation speed exceeded the value set on the Overspeed Level set (Pn513).	√	√	√
	1	Overspeed 2	The motor rotation speed exceeded the value set on the Overspeed Level set 2 (Pn615).	√	√	–
27	0	Command Pulse Frequency Error	A command pulse frequency error was detected.	√	√	√
	2	Command Pulse Multiplier Error	The command pulse divider or multiplier is not suitable.	√	√	√
28	0	Pulse Regeneration Error	The pulse regeneration output frequency exceeded the limit.	√	√	√

Alarm No.		Error detection function	Description and error cause	Attribute		
Main	Sub			History	Can be cleared	Immediate stop ^{*1}
29	0	Error Counter Overflow	Error counter value based on the encoder pulse reference exceeded 2^{29} (536,870,912).	√	√	—
33	0	Interface Input Duplicate Allocation Error 1	A duplicate setting for the interface input signals was detected.	√	—	—
	1	Interface Input Duplicate Allocation Error 2		√	—	—
	2	Interface Input Function Number Error 1	An undefined number was detected in the interface input signal allocations.	√	—	—
	3	Interface Input Function Number Error 2		√	—	—
	4	Interface Output Function Number Error 1	An undefined number was detected in the interface output signal allocations.	√	—	—
	5	Interface Output Function Number Error 2		√	—	—
	6	Counter Reset Allocation Error	The counter reset function was allocated to something other than input signal SI7.	√	—	—
	7	Command Pulse Prohibition Input Allocation Error	The command pulse prohibition input function was allocated to something other than input signal SI10.	√	—	—
34	0	Overrun Limit Error	The motor exceeded the allowable operating range set in the Overrun Limit Setting (Pn514) with respect to the position command input.	√	√	—
36	0-2	Parameter Error	Data in the Parameter Save area was corrupted when the power supply was turned ON and data was read from the EEPROM.	—	—	—
37	0-2	Parameter destruction	The checksum for the data read from the EEPROM when the power supply was turned ON does not match.	—	—	—
38	0	Drive Prohibition Input Error	The forward drive prohibition and reverse drive prohibition inputs are both turned OFF.	—	√	—
43	0	Encoder Initialization Error	An encoder initialization error was detected.	√	—	—
44	0	Encoder 1-rotation Counter Error	A 1-turn counter error was detected.	√	—	—
45	0	Multi-rotation Counter Error	A multi-rotation counter error or phase-AB signal error was detected.	√	—	—
48	0	Encoder Phase-Z Error	A serial incremental encoder phase Z pulse irregularity was detected.	√	—	—
49	0	Encoder CS Signal Error	A logic error was detected in the CS signal for serial incremental encoder.	√	—	—
55	0	Phase-A Connection Error	An error was detected in the external encoder phase A connection.	√	—	—
	1	Phase-B Connection Error	An error was detected in the external encoder phase B connection.	√	—	—
	2	Phase-Z Connection Error	An error was detected in the external encoder phase Z connection.	√	—	—

Alarm No.		Error detection function	Description and error cause	Attribute		
Main	Sub			History	Can be cleared	Immediate stop ^{*1}
87	0	Emergency Stop Input Error	An emergency stop input signal (STOP) was input.	–	√	–
95	0-4	Motor Non-conformity	The combination of the Servomotor and Servo Drive is not appropriate. The encoder was not connected when the power supply was turned ON.	–	–	–
Other numbers		Other errors	The control circuit malfunctioned due to excess noise or some other problem.	√	–	–

*1 "Immediate stop" means alarms which cause an immediate stop when Stop Selection for Alarm Detection (Pn510) is set to 4 to 7. For details, refer to *Stop Selection for Alarm Detection* on page 7-46.

10-4 Troubleshooting

If an error occurs in the machine, determine the error conditions from the alarm display and operation state, identify the cause of the error, and take appropriate measures.

10-4-1 Error Diagnosis with Alarm Displays

Alarm No.		Name	Cause	Measures
Main	Sub			
11	0	Control Power Supply Undervoltage	<p>The voltage across the positive and negative terminals in the control power supply converter dropped below the specified value.</p> <p>200-V products: Approx. 145 VDC (Approx. 100 VAC)</p> <ul style="list-style-type: none"> • The power supply voltage is low. A momentary power interruption occurred. • Insufficient power supply capacity: The power supply voltage dropped because there was inrush current when the main power supply was turned ON. • The Servo Drive is faulty (circuit fault). 	<p>Measure the voltage across the L1C and L2C lines on the connectors and the terminal block.</p> <ul style="list-style-type: none"> • Increase the power supply voltage. Change the power supply. • Increase the power supply capacity. • Replace the Servo Drive.
12	0	Overvoltage	<p>The power supply voltage exceeded the allowable input voltage range, causing the voltage across the positive and negative terminals in the converter to exceed the specified value. The power supply voltage is high. The voltage was suddenly increased by the phase advance capacitor or the uninterruptible power supply (UPS).</p> <p>200-V products: Approx. 400 VDC (Approx. 280 VAC)</p> <ul style="list-style-type: none"> • The Regeneration Resistor wiring is broken. • The External Regeneration Resistor is inappropriate and cannot absorb all of the regenerative energy. The load inertia is too large, gravitational torque on the vertical axis is too large, or there is some other problem to absorb the regenerative energy. • The Servo Drive is faulty (circuit fault). 	<p>Measure the voltage across the L1, L2, and L3 lines on the connectors and the terminal block.</p> <p>Input the correct voltage. Remove the phase advance capacitor.</p> <ul style="list-style-type: none"> • Use a tester to measure the resistance of the external resistor between the B1 and B2 terminals on the Servo Drive. If the resistance is infinite, the wiring is broken. Replace the external resistor. • Change the regeneration resistance and wattage to the specified values. Calculate the regenerative energy and connect an External Regeneration Resistor with the required regeneration absorption capacity. Reduce the descent speed. • Replace the Servo Drive.

Alarm No.		Name	Cause	Measures
Main	Sub			
13	0	Main Power Supply Undervoltage (insufficient voltage between P and N)	If Undervoltage Alarm Selection (Pn508) is set to 1, a momentary power interruption occurred between L1 and L3 for longer than the value set in Momentary Hold Time (Pn509). Alternatively, the voltage across the positive and negative terminals in the main power supply converter dropped below the specified value while the servo was ON. 200-V products: Approx. 110 VDC (Approx. 75 VAC) <ul style="list-style-type: none"> • The power supply voltage is low. • A momentary power interruption occurred. • Insufficient power supply capacity: The power supply voltage dropped because there was inrush current when the main power supply was turned ON. • Phase loss: A Servo Drive with 3-phase input specifications was operated with single-phase power supply. • The Servo Drive is faulty (circuit fault). 	Measure the voltage across the L1, L2, and L3 lines on the connectors and the terminal block. <ul style="list-style-type: none"> • Increase the power supply voltage. Change the power supply. • Eliminate the cause of the failure of the electromagnetic contactor on the main circuit power supply, and then turn ON the power again. • Check the value set in Momentary Hold Time (Pn509). Set each phase of the power supply correctly. • Increase the power supply capacity. Refer to 2-3-3 <i>Servo Drive and Servomotor Combination Tables</i> on page 2-11 for information on the power supply capacity. • Connect each phase (L1, L2, and L3) of the power supply correctly. Use L1 and L3 for single-phase 100 V and single-phase 200 V. • Replace the Servo Drive.
	1	Main Power Supply Undervoltage (AC cutoff detected)		
14	0	Overcurrent	The current flowing between the positive and negative terminals in the converter exceeded the specified value. <ul style="list-style-type: none"> • The Servo Drive is faulty (faulty circuit, faulty IGBT part, etc.). • The Servomotor cable is short-circuited between phases U, V, and W. • The Servomotor cable is ground-faulted. • Motor windings are burned out. • The Servomotor wiring contacts are faulty. • The relay for the dynamic brake has been welded due to frequent servo ON/OFF operations. • The command pulse input timing is the same as or earlier than the Servo ON timing. 	<ul style="list-style-type: none"> • Disconnect the Servomotor cable, and turn ON the servo. If the problem immediately recurs, replace the Servo Drive with a new one. • Check to see if the Servomotor cable is short-circuited between phases U, V and W by checking for loose wire strands on the connector lead. Connect the Servomotor cable correctly. • Check the insulation resistance between phases U, V, and W of the Servomotor cable and the grounding wire of the Servomotor. If the insulation is faulty, replace the Servomotor. • Check the balance between the resistance of each wire of the Servomotor. If resistance is unbalanced, replace the Servomotor. • Check for missing connector pins in Servomotor connections U, V, and W. If any loose or missing connector pins are found, secure them firmly. • Replace the Servo Drive. The servo does not turn ON for a period of 3 minutes after the use of the dynamic brake. • Wait at least 100 ms after the servo has turned ON, then input commands.
	1	IPM Error		

Alarm No.		Name	Cause	Measures
Main	Sub			
15	0	Servo Drive Overheat	<p>The temperature of the Servo Drive radiator or power elements exceeded the specified value.</p> <ul style="list-style-type: none"> The ambient temperature of the Servo Drive exceeded the specified value. Overload 	<ul style="list-style-type: none"> Improve the ambient temperature and the cooling conditions of the Servo Drive. Increase the capacities of the Servo Drive and the Servomotor. Set longer acceleration and deceleration times. Reduce the load.
16	0	Overload ^{*1}	<p>When the feedback value for torque command exceeds the overload level specified in Overload Detection Level Setting (Pn512), overload protection is performed according to the overload characteristics.</p> <ul style="list-style-type: none"> The load was heavy, the effective torque exceeded the rated torque, and operation continued too long. Vibration or hunting occurred due to faulty gain adjustment. The Servomotor vibrates or makes unusual noise. The value set in Inertia Ratio 1 (Pn004) is faulty. The Servomotor wiring is incorrect or broken. The machine was hit by an object, or the machine load suddenly became heavy. The machine was distorted. The electromagnetic brake remains ON. When multiple machines were wired, the wiring was incorrect and the Servomotor cable was connected to a Servomotor for another axis. 	<p>Check if torque (current) waveforms oscillate or excessively swing vertically with analog output or CX-Drive. Check the overload warning display and the load ratio through communications.</p> <ul style="list-style-type: none"> Increase the capacities of the Servo Drive and the Servomotor. Set longer acceleration and deceleration times. Reduce the load. Readjust the gain. Connect the Servomotor cable as shown in the wiring diagram. Replace the cable. Remove the distortion from the machine. Reduce the load. Turn OFF the brake. Wire the Servomotor and the encoder correctly so that the wiring matches the axes.
18	0	Regeneration Overload ^{*2}	<p>The regenerative energy exceeds the processing capacity of the Regeneration Resistor.</p> <ul style="list-style-type: none"> The regenerative energy during deceleration caused by a large load inertia increased the converter voltage across the positive and negative terminals, and then insufficient energy absorption by the Regeneration Resistor further increased the voltage. The Servomotor rotation speed is too high to absorb the regenerative energy within the specified deceleration time. The operating limit of the external resistor is limited to a 10% duty. 	<p>Check the load ratio of the Regeneration Resistor with CX-Drive. This Regeneration Resistor cannot be used for continuous regenerative braking.</p> <ul style="list-style-type: none"> Check the operation pattern (speed monitor). Check the load ratio of the Regeneration Resistor and check for the excessive regeneration warning display. Increase the capacities of the Servo Drive and the Servomotor, and lengthen the deceleration time. Reduce the Servomotor rotation speed. Use an External Regeneration Resistor. Set Regeneration Resistor Selection (Pn016) to 2.
	1	Regeneration Tr Error	<p>The Servo Drive regeneration drive Tr is faulty.</p>	<p>Replace the Servo Drive.</p>

Alarm No.		Name	Cause	Measures
Main	Sub			
21	0	Encoder Communications Disconnection Error	A disconnection was detected because communications between the encoder and the Servo Drive were stopped more frequently than the specified value.	Wire the encoder correctly as shown in the wiring diagram. Correct the connector pin connections.
	1	Encoder Communications Error	There was a communications error in data from the encoder. There was a data error mainly due to noise. The encode cable is connected, but a communications data error occurred.	<ul style="list-style-type: none"> • Provide the required encoder power supply voltage 5 VDC \pm5% (4.75 to 5.25 VDC). Be careful especially when the encode cable is long. • If the Servomotor cable and the encoder cable are bundled together, separate them. • Connect the encoder cable correctly.
23	0	Encoder Communications Data Error	No communications error occurred with data from the encoder, but there is an error in the contents of the data. There was a data error mainly due to noise. The encode cable is connected, but a communications data error occurred.	<ul style="list-style-type: none"> • Provide the required encoder power supply voltage 5 VDC \pm5% (4.75 to 5.25 VDC). Be careful especially when the encode cable is long. • If the Servomotor cable and the encoder cable are bundled together, separate them. • Connect the encoder cable correctly.
24	0	Error Counter Overflow	Position error pulses exceeded the value set in Error Counter Overflow Level (Pn014). <ul style="list-style-type: none"> • Motor operation does not follow the command. • The value set in Error Counter Overflow Level (Pn014) is small. 	<ul style="list-style-type: none"> • Check to see if the Servomotor rotates according to the position command pulses. Check with the torque monitor to see if the output torque is saturated. Adjust the gain. Maximize the values set in No.1 Torque Limit value (Pn013) and No.2 Torque Limit value (Pn522). Connect the encoder cable correctly. Lengthen the acceleration and deceleration times. Reduce the load and the speed. • Increase the value set in Error Counter Overflow Level (Pn014).
	1	Excessive Speed Error ^{*3}	The difference between the Internal Position Command Speed and the motor speed (speed deviation) exceeded the value set in Excessive Speed Error Setting (Pn602).	<ul style="list-style-type: none"> • Increase the value set in Excessive Speed Error Setting (Pn602). • Lengthen the acceleration and deceleration times for the Internal Position Command Speed. Or adjust the gain to improve the speed-following performance. • Disable Excessive Speed Error Setting (Pn602 = 0).
26	0	Overspeed	The Servomotor rotation speed exceeded the value set in Overspeed Detection Level Setting (Pn513).	<ul style="list-style-type: none"> • Do not give excessive speed commands. • Check the input frequency, dividing ratio, and multiplication ratio of the command pulses. • If overshooting occurred due to faulty gain adjustment, adjust the gain. • Connect the encoder cable correctly.
	1	Overspeed 2	The Servomotor rotation speed exceeded the value set in Overspeed Detection Level Setting at Emergency Stop (Pn615).	

Alarm No.		Name	Cause	Measures
Main	Sub			
27	0	Command Pulse Frequency Error	The command pulse input frequency exceeded the value set in Command Pulse Input Maximum Setting (Pn532) x 1.2.	Check the command pulse input.
	2	Command Pulse Multiplier Error	The parameter setting for the command pulse frequency or the electronic gear ratio is not appropriate. The value obtained by multiplying the number of command pulses per 0.167 ms by the electronic gear ratio exceeded approximately 3 Gpps (approximately 175 kpps for software versions earlier than V1.10). The command pulse input is sparse or dense. There is an erroneous count due to noise contained in the command pulse input.	<ul style="list-style-type: none"> Set the electronic gear ratio as small as possible in the range of 1/1,000 to 1,000 times. Check the command pulse input. Use the line driver interface if possible. Set Command Pulse Input Maximum Setting (Pn532) to less than 1,000 and enable the digital filter.
28	0	Pulse Regeneration Error	The pulse regeneration output frequency exceeded the allowable limit.	<ul style="list-style-type: none"> Check the values set in Encoder Dividing Numerator (Pn011) and Encoder Dividing Denominator (Pn503). To disable the detection, set Pulse Regeneration Limit Setting (Pn533) to 0.
29	0	Error Counter Overflow	The position error counter value obtained with reference to the encoder pulses exceeded $+2^{29}$ (536,870,912).	<ul style="list-style-type: none"> Check to see if the Servomotor rotates according to the position command. Check with the torque monitor to see if the output torque is saturated. Adjust the gain. Maximize the values set in No.1 Torque Limit value (Pn013) and No.2 Torque Limit value (Pn522). Wire the encoder cable correctly.
33	0	Interface Input Duplicate Allocation Error 1	There is a duplicate setting in the input signal (IN1, IN2 IN3, IN4, or IN5) function allocations.	Make sure that functions are correctly allocated to these connector pins.
	1	Interface Input Duplicate Allocation Error 2	There is a duplicate setting in the input signal (IN6, IN7, IN8, IN9, or IN10) function allocations.	
	2	Interface Input Function Number Error 1	There is an undefined number specification in the input signal (IN1, IN2, IN3, IN4, or IN5) function allocations.	
	3	Interface Input Function Number Error 2	There is an undefined number specification in the input signal (IN6, IN7, IN8, IN9, or IN10) function allocations.	
	4	Interface Output Function Number Error 1	There is an undefined number specification in the output signal (SO1 or SO2) function allocation.	
	5	Interface Output Function Number Error 2	There is an undefined number specification in the output signal (SO4) function allocation.	
	6	Counter Reset Allocation Error	The Error Counter Reset Input (ECRST) pin was allocated to other than the input signal S17.	
7	Command Pulse Prohibition Input Allocation Error	The Pulse Prohibition Input (IPG) function was allocated to other than the input signal SI10.		

Alarm No.		Name	Cause	Measures
Main	Sub			
34	0	Overrun Limit Error	The Servomotor exceeded the allowable operating range set in Overrun Limit Setting (Pn514) with respect to the position command input range. <ul style="list-style-type: none"> The gain is not appropriate. The value set in Pn514 is too small. 	Check the gain (the balance between the position loop gain and the speed loop gain) and the inertia ratio. <ul style="list-style-type: none"> Increase the value set in Pn514. Or set Pn514 to 0 to disable the protective functions.
36	0	Parameter Error	Data in the Parameter Save Area was corrupted when the power supply was turned ON and data was read from the EEPROM.	<ul style="list-style-type: none"> Set all of the parameters again. If this error occurs repeatedly, the Servo Drive may be faulty. In this case, replace the Servo Drive.
	1			
	2			
37	0	Parameter destruction	EEPROM write verification data was corrupted when the power supply was turned ON and data was read from the EEPROM.	The Servo Drive is faulty. Replace the Servo Drive.
	1			
	2			
38	0	Drive Prohibition Input Error	When Drive Prohibition Input Selection (Pn504) was set to 0, both the Forward Drive Prohibition Input (POT) and Reverse Drive Prohibition Input (NOT) signals turned ON. When Pn504 was set to 2, either the Forward Drive Prohibition Input or Reverse Drive Prohibition Input signal turned ON.	Check for any problems with the switches, wires, and power supplies that are connected to the Forward Drive Prohibition Input or Reverse Drive Prohibition input pin. In particular, check to see if the external power supply (12 to 24) for sequence input turns ON too slowly.
43	0	Encoder Initialization Error	An error was detected during encoder initialization.	Replace the Servomotor.
44	0	Encoder 1-rotation Counter Error	An encoder 1-rotation counter error was detected.	Replace the Servomotor.
45	0	Multi-rotation Counter Error	An encoder multi-rotation counter error was detected.	Replace the Servomotor.
48	0	Encoder Phase-Z Error	A missing phase-Z pulse was detected in the serial incremental encoder. The encoder is faulty.	Replace the Servomotor.
49	0	Encoder CS Signal Error	A logic error was detected in the serial incremental encoder CS signal. The encoder is faulty.	Replace the Servomotor.
55	0	Phase-A Connection Error	An error such as broken wiring was detected in the external encoder phase-A connection.	Check the external encoder phase-A connection.
	1	Phase-B Connection Error	An error such as broken wiring was detected in the external encoder phase-B connection.	Check the external encoder phase-B connection.
	2	Phase-Z Connection Error	An error such as broken wiring was detected in the external encoder phase-Z connection.	Check the external encoder phase-Z connection.
87	0	Emergency Stop Input Error	The Emergency Stop (STOP) signal was input.	Check the Emergency Stop (STOP) signal wiring.
95	0-4	Motor Non-conformity	The Servomotor does not match the Servo Drive.	Replace the Servomotor with one that matches the Servo Drive.
Other numbers		Other errors	The control circuit malfunctioned due to excess noise or some other problem. The self-diagnosis function of the Servo Drive was activated, and an error occurred in the Servo Drive.	<ul style="list-style-type: none"> Turn OFF the power once, and turn it ON again. If the error is displayed even after the power is turned ON again, the system may be faulty. Stop using the system, and replace the motor and/or the Servo Drive.

- *1 For the overload characteristics, refer to *3-2 Overload Characteristics (Electronic Thermal Function)* on page 3-35.
- *2 Always install a thermal switch when setting the Regeneration Resistor Selection (Pn016) value to 2. Otherwise, the Regeneration Resistor will not be protected, generate excessive heat, and be burned out.
- *3 When the Internal Position Command Speed is force-set to 0 during an immediate stop due to the Pulse Prohibition Input (IPG) or Forward/Reverse Drive Prohibition Input, the speed deviation immediately increases. The speed deviation also increases at the rising edge of the Internal Position Command Speed. Therefore, provide enough margin when configuring the settings.

10-4-2 Error Diagnosis Using the Operation State

Symptom	Probable cause	Check items	Measures
The PWR indicator does not light when the Servo Drive is powered on.	The power supply wiring is incorrect.	Check to see if the power supply input is within the allowed power supply voltage range.	Supply the correct power supply voltage.
		Check to see if the power supply input is wired correctly.	Wire correctly.
The Servomotor does not rotate when a command is input from the controller.	The Operation Command (RUN) signal is OFF.	Check in the monitor mode if the RUN signal turns ON/OFF.	<ul style="list-style-type: none"> Input the Operation Command (RUN) signal. Wire correctly.
	Forward Drive Prohibition Input (POT) or Reverse Drive Prohibition Input (NOT) signal is OFF.	Check in the monitor mode if the POT and NOT signals turn ON/OFF.	<ul style="list-style-type: none"> Turn ON the POT or NOT signal. Disable the parameter if the POT or NOT signal is not used.
	The control mode does not conform to the command.	Check the value set in Control Mode Selection (Pn001).	Set the control mode according to the command.
	The Error Counter Reset Input (ECRST) signal is ON.	Check in the monitor mode if the ECRST signal turns ON/OFF.	<ul style="list-style-type: none"> Turn OFF the ECRST signal. Wire correctly.
	The value set in Command Pulse Mode Selection (Pn007) is incorrect.	Check the command pulse type of the controller and that of the Servo Drive.	Set the command pulse type of the Servo Drive so that it matches the command pulse type of the controller.
	The Zero Speed Designation Input (VZERO) signal is OFF.	Check in the monitor mode if the VZERO signal turns ON/OFF.	<ul style="list-style-type: none"> Turn ON the VZERO signal. Wire correctly.
	No internally set speeds are set.	Check the values set in Pn304 to Pn311.	Set the desired rotation speed.
	The values set in No.1 Torque Limit (Pn013) and No.2 Torque Limit (Pn522) are 0.	Check the values set in Pn013 and Pn522.	Restore the default set values.
	The Servomotor power cable is wired incorrectly.	Check the wiring.	Wire correctly.
	The encoder cable is wired incorrectly.		
	The control I/O connector (CN1) is wired incorrectly.	Check the command pulse wiring.	Wire correctly.
		Check the command pulse type.	Set the command pulse type of the Servo Drive so that it matches the command pulse type of the controller.
		Check the command pulse voltage.	Connect resistors appropriate for the voltage.
	Power is not supplied.	Check the power supply and the PWR indicator.	Turn ON the power supply.
Check the voltage across the power terminals.		Wire the power-on circuit correctly.	
The speed command is disabled.	Check to see if the speed command input method is correct.	<ul style="list-style-type: none"> Set the internal speed correctly. 	
The torque command is disabled.	Check to see if the torque command input method is correct.	Set the torque command correctly.	
Both the CW and CCW inputs are turned ON simultaneously.	Check the command pulse wiring.	<ul style="list-style-type: none"> Input the pulse signal to either the CW or CCW input. Unused input terminals must be always OFF. 	
The Servo Drive is faulty.	—	Replace the Servo Drive.	

Symptom	Probable cause	Check items	Measures
The Servomotor operates momentarily, but then it does not operate after that.	The Servomotor power cable is wired incorrectly.	Check the wiring of the Servomotor power cable phases U, V, and W.	Wire correctly.
	The encoder cable is wired incorrectly.	Check the encoder cable wiring.	Wire correctly.
The Servomotor rotates without a command.	The command pulse input is incorrect.	Check the command pulse type.	Make sure that the command pulse input is appropriate.
		Check the command pulse voltage.	Connect a resistor that matches the voltage.
	The Servo Drive is faulty.	–	Replace the Servo Drive.
The Servomotor rotates opposite to the command direction.	The CW input and the CCW input are connected in reverse.	Check the command pulse type of the controller and that of the Servo Drive.	Connect the CW pulse signal to the CW input and the CCW pulse signal to the CCW input, respectively.
Motor rotation is unstable.	The Servomotor power cable or encoder cable is wired incorrectly.	Check the wiring of the Servomotor power cable phases U, V, and W and that of the encoder cable.	Wire correctly.
	The load torque fluctuates due to eccentricity of the coupling that connects the motor shaft to mechanical systems, loose screws, or poor engagement between the pulley and the gear.	Check the connection to mechanical systems.	Recheck and adjust the machine.
		Try to operate the Servomotor with no load (by disconnecting the motor from mechanical systems).	
	The load's moment of inertia exceeds the Servo Drive's allowable value.	Try to operate the Servomotor with no load (by disconnecting the motor from mechanical systems).	<ul style="list-style-type: none"> • Reduce the load. • Replace the Servomotor and the Servo Drive with larger capacity ones.
	Pulse signal lines are connected poorly.	Check the pulse signal wiring for the controller and the Servo Drive.	Wire correctly.
		Check the command pulse type of the controller and that of the Servo Drive.	Set the command pulse type of the Servo Drive so that it matches the command pulse type of the controller.
	The gain setting is inappropriate.	–	Perform manual tuning.
Chattering occurs in an input signal to CN1.	Check the Operation Command (RUN), Error Counter Reset Input (ECRST), Zero Speed Designation Input (VZERO), and Internally Set Speed 1/2 (VSEL1/VSEL2) signals.	Wire correctly to prevent chattering.	
The Servomotor is overheating.	The ambient temperature is too high.	Check to see if the ambient temperature around the Servomotor is over 40°C.	Lower the ambient temperature around the Servomotor to 40°C or less. (Use a fan or air conditioner.)
	Ventilation is blocked.	Check to see if ventilation is blocked.	Take measures to improve ventilation.
	The Servomotor is overloaded. The Servomotor vibrates during operation.	Try to operate the Servomotor with no load (by disconnecting the motor from mechanical systems).	<ul style="list-style-type: none"> • Reduce the load. • Replace the Servomotor and the Servo Drive with larger capacity ones.
The Servomotor's holding brake does not work.	Power is supplied to the holding brake.	Check to see if power is supplied to the holding brake.	Design the circuit so that stopping the Servomotor causes the power supply to the holding brake to turn OFF when it holds a load.

Symptom	Probable cause	Check items	Measures
The Servomotor does not stop or is hard to stop even if the Operation Command (RUN) signal is turned OFF while the Servomotor is rotating.	The load inertia is too large.	Check for the following: <ul style="list-style-type: none"> • Is the load too high? • Is the motor speed too high? 	Review the load conditions and replace the Servomotor and the Servo Drive with proper ones.
	The stop circuit is faulty.	–	Replace the Servo Drive.
The Servomotor generates abnormal noise or vibration.	The mechanical installation of the Servomotor is improper.	Check to see if the Servomotor mounting screws are loose.	Retighten the mounting screws.
		Check to see if the coupling is installed eccentrically.	Center the coupling.
		Check to see if the coupling is unbalanced.	Adjust the coupling balance.
	There is a problem with the bearings.	Check for noise or vibration around the bearings.	Contact the OMRON dealer or sales office.
	The gain setting is inappropriate.	–	Perform manual tuning.
	The value set in Speed Feedback Filter Time Constant (Pn103) is inappropriate.	Check the value set in Pn103.	Restore the default value 0 or increase the set value.
	The control I/O signal cable is affected by noise because it does not meet the specifications.	Check to see if the cable is a twisted-pair cable or common shielded twisted-pair cable with at least 0.08-mm ² core wires.	Use a control I/O signal cable that meets the specifications.
	The control I/O signal cable is affected by noise because it is longer than the specified length.	Check the length of the control I/O signal cable.	Limit the wiring length of the control I/O signal cable to 3 m or less.
	The encoder cable is affected by noise because it does not meet the specifications.	Check to see if the cable is a common shielded twisted-pair cable with at least 0.12-mm ² core wires.	Use an encoder cable that meets the specifications.
	The encoder cable is affected by noise because it is longer than the specified length.	Check the length of the encoder cable.	Limit the wiring length of encoder cables to 20 m or less.
	The encoder cable is affected by noise because it is stuck by something or has a torn sheath.	Check the encoder cable for damage.	Correct the encoder cabling.
	The encoder cable is affected by excessive noise.	Check to see if the encoder cable is bound together with or too close to high-current lines.	Install the encoder cable where it is not subject to surges.
	The FG's potential fluctuates due to equipment installed near the Servomotor, such as a welding machine.	Check for grounding problems (loss of ground or incomplete ground) of equipment such as a welding machine installed near the Servomotor.	Ground the equipment properly to prevent the current from flowing into the external encoder's FG.
The encoder fails due to excessive vibration or shock.	There is a problem of mechanical vibration or defective motor installation (low mounting surface accuracy, poor fixing, eccentric mounting).	Reduce the mechanical vibration or correct the Servomotor mounting conditions.	

Symptom	Probable cause	Check items	Measures
The Servomotor generates abnormal noise or vibration. (continue)	There is a resonance between the machine and the motor.	Check to see if there is a mechanical resonance.	<ul style="list-style-type: none"> Readjust the Torque Command Filter Time Constant values. If there is a resonance, set the following parameters: Notch 1 Frequency Setting (Pn201), Notch 1 Width Setting (Pn202), Notch 1 Depth Setting (Pn203).
Vibration occurs at the same frequency as the commercial power supply frequency.	Inductive noise is present.	Check to see if the control signal wiring of the Servo Drive is too long.	Shorten the control signal line.
		Check to see if the control signal line and power supply line are bound together.	<ul style="list-style-type: none"> Move the control signal line away from power supply line. Use a low-impedance power supply for control signals.
The Servomotor falls out of position. (Positional deviation occurs without alarm output.)	There is an error in the coupling between mechanical systems and the Servomotor.	Check to see if positional deviation occurs in the coupling between mechanical systems and the Servomotor.	Correct the coupling between mechanical systems and the Servomotor.
	<ul style="list-style-type: none"> The Error Counter Reset Input (ECRST) signal is affected by noise. The position command pulse (CW or CCW) input signal is affected by noise. 	Check to see if the control signal line and power supply line are bound together.	Take measures against noise; for example, separating the control signal line from the power supply line.
		Check to see if the cable is a common shielded twisted-pair cable with at least 0.08-mm ² core wires.	Use a control I/O signal cable that meets the specifications.
		Check the length of the control I/O signal cable.	Limit the wiring length of the control I/O signal cable to 10 m or less for line driver input and 3 m or less for open collector input.
	The gain setting is inappropriate.	—	Perform manual tuning.
	The load inertia is too large.	Check for the following: <ul style="list-style-type: none"> Is the load too high? Is the motor speed too high? 	<ul style="list-style-type: none"> Adjust the gain. Review the load conditions and replace the Servomotor and the Servo Drive with proper ones.

10-5 Periodic Maintenance

Caution



After replacing the Servo Drive, transfer to the new Servo Drive all data needed to resume operation, before restarting operation.
Equipment damage may result.



Never repair the Servo Drive by disassembling it.
Electric shock or injury may result.

Servomotors and Servo Drives contain many components and will operate properly only when each of the individual components is operating properly.

Some of the electrical and mechanical components require maintenance depending on application conditions. Periodic inspection and replacement are necessary to ensure proper long-term operation of Servomotors and Servo Drives. (Quoted from The Recommendation for Periodic Maintenance of a General-purpose Inverter published by JEMA.)

The periodic maintenance cycle depends on the installation environment and application conditions of the Servomotors and Servo Drives.

Recommended maintenance times are given below for Servomotors and Servo Drives. Use these for reference in periodic maintenance.

10-5-1 Servomotor Life Expectancy

- The lifetimes for the different motor parts are listed below.

Bearings: 20,000 hours

Decelerator: 20,000 hours

Oil seal: 5,000 hours

Encoder: 30,000 hours

These values assume a motor operating ambient temperature of 40°C, a shaft load within the specified value, rated operation (rated torque and rated rotation speed), and proper installation as described in this manual.

The bearings, decelerator, oil seal, and encoder can be replaced for repair.

- The radial load during Servomotor operation on timing pulleys and other components contacting belts is two or more times the static load or more. Consult with the belt and pulley manufacturers and adjust designs and system settings so that the motor allowable axial load is not exceeded even during operation. If a motor is used under a shaft load exceeding the allowable limit, the motor shaft can break and the bearings can be damaged.

10-5-2 Servo Drive Life Expectancy

- The lifetimes for the different drive parts are given below.
- Aluminum electrolytic capacitors: 28,000 hours
(at a drive operating ambient temperature of 50°C, constant output at rated torque, constant output at rated rotation speed, and installation as described in this manual)
Axial-flow fan: 10,000 to 30,000 hours (The limit depends on the operating conditions.)
Inrush current prevention relay: Approximately 20,000 operations (The limit depends on the operation conditions.)
- When using the Servo Drive in continuous operation, use fans or air conditioners to maintain the ambient temperature below 40°C.
- We recommend that the ambient temperature and the power supply ON time be reduced as much as possible to lengthen the service life of the Servo Drive.
- The limit of aluminum electrolytic capacitors is greatly affected by the operating ambient temperature. Generally, an increase of 10°C in the operating ambient temperature will reduce capacitor service life by 50%.
- The aluminum electrolytic capacitors deteriorate even when the Servo Drive is stored with no power supplied. If the Servo Drive is not used for a long time, we recommend periodic inspection and a part replacement period of 5 years.
- If the Servomotor or Servo Drive is not to be used for a long time, or if they are to be used under conditions worse than those described above, a periodic inspection period of 5 years is recommended.
- Upon request, OMRON will inspect the Servo Drive and Servomotor and determine if part replacement is required.

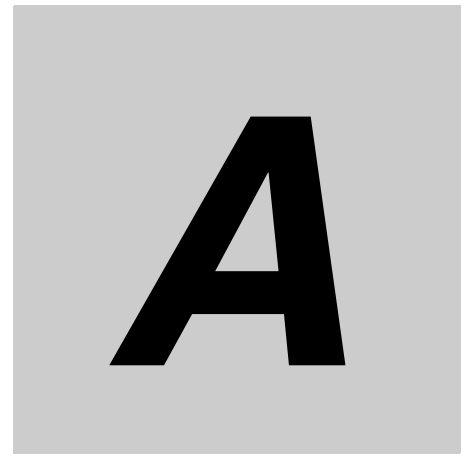

Appendices

The appendices provide connection examples with OMRON's PLC and Position Controller, as well as lists of parameters.

A-1 Connection Examples	A-2
A-2 Parameter List	A-11

A-1 Connection Examples

Example 1: Connection with SYSMAC CJ1W-NC133/233/433

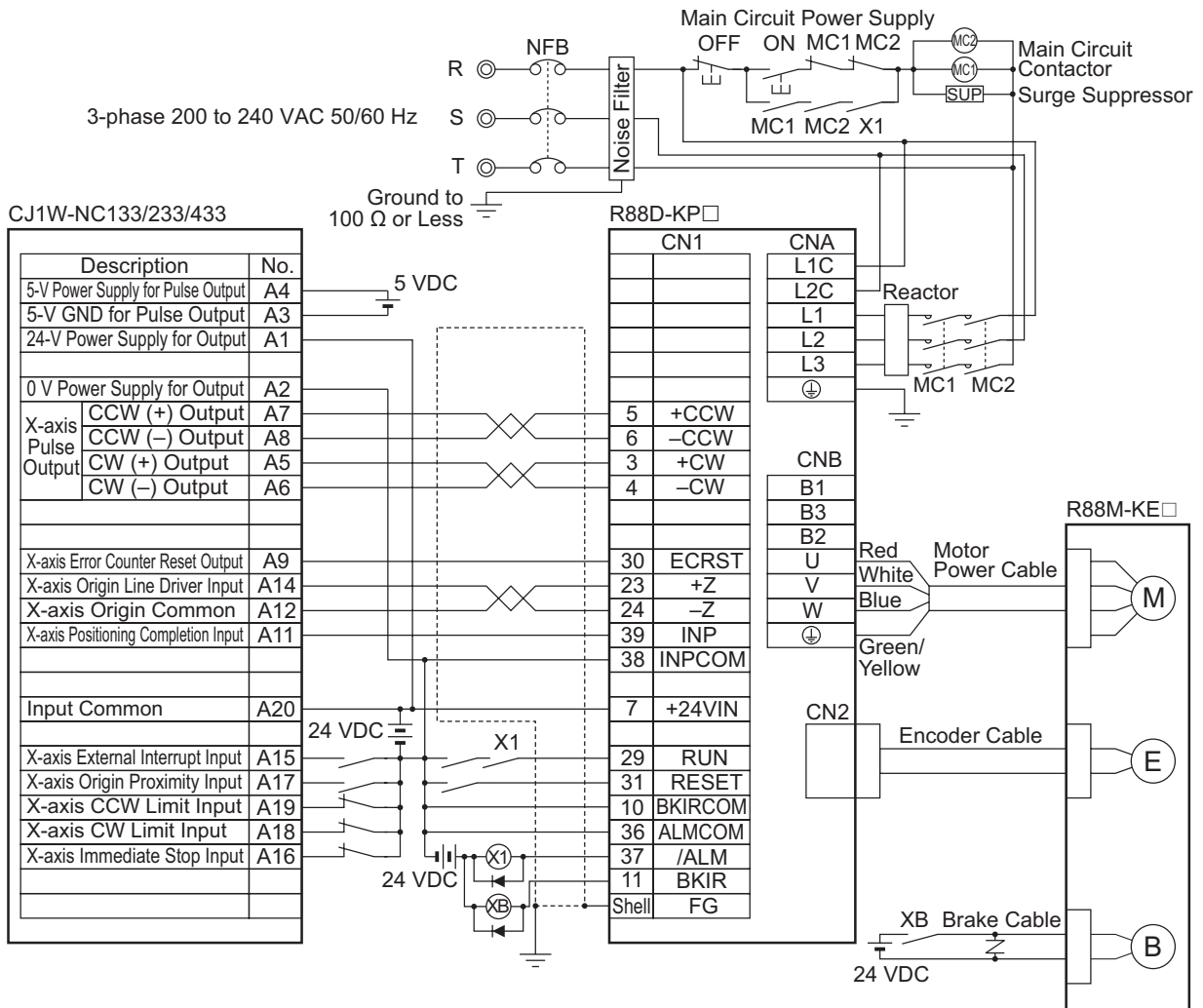

Precautions for Correct Use

- The above example shows an example of connecting a Servo Drive with 3-phase 200 VAC main circuit power supply inputs. Use a power supply and power cables that meet the power supply specifications of the Servo Drive.
- Note that incorrect connection of signal lines may cause damage to the Servo Drive and connected units.
- Leave unused signal wires disconnected and open.
- Use mode 2 for origin search.
- Recommended surge-absorbing diode: RU2 (Sanken Electric Co., Ltd.) or equivalent
- Connect signal lines so that the servo can be turned ON and OFF with the RUN signal.

Example 2: Connection with SYSMAC CJ1W-NC113/213/413

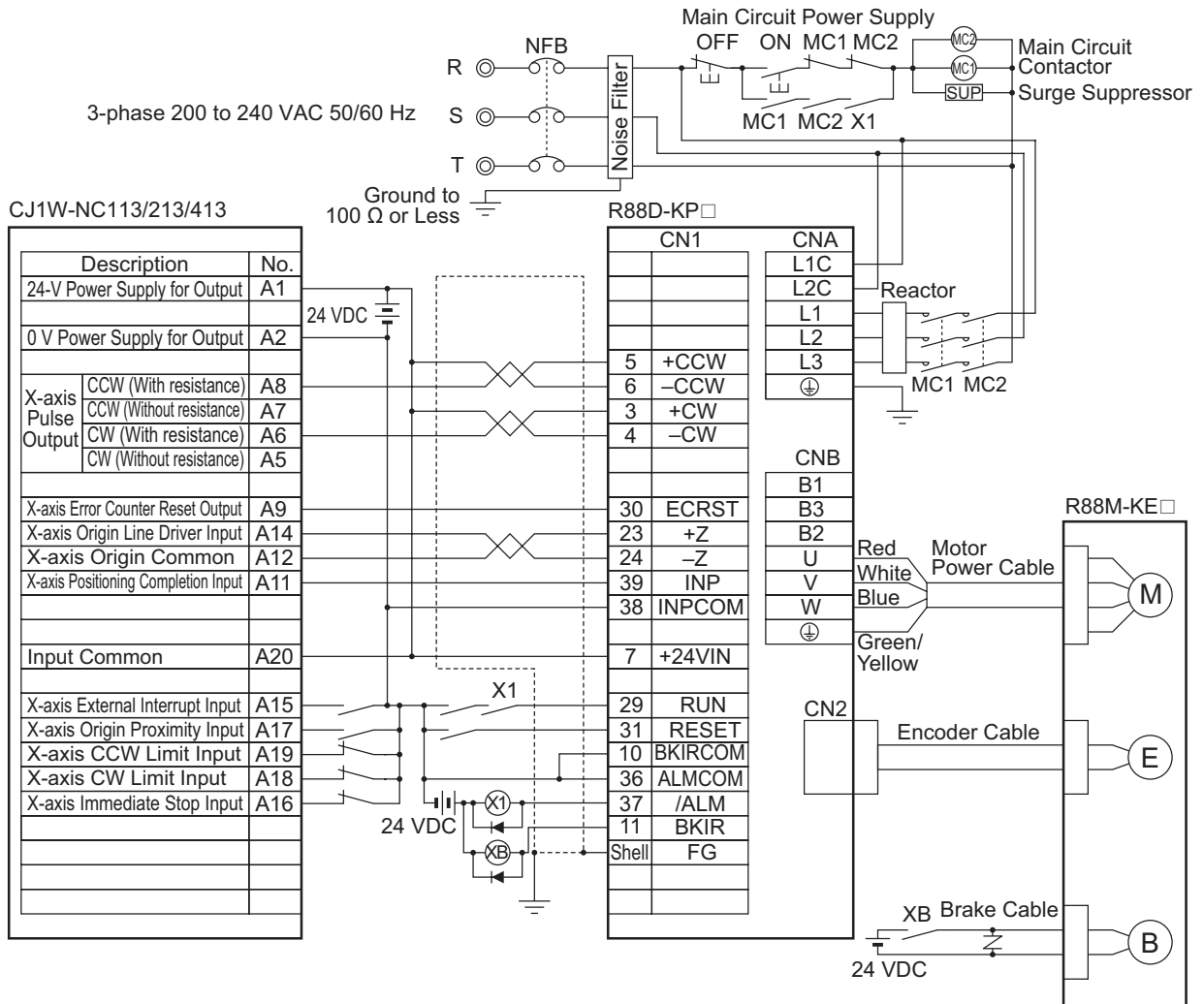

Precautions for Correct Use

- The above example shows an example of connecting a Servo Drive with 3-phase 200 VAC main circuit power supply inputs. Use a power supply and power cables that meet the power supply specifications of the Servo Drive.
- Note that incorrect connection of signal lines may cause damage to the Servo Drive and connected units.
- Leave unused signal wires disconnected and open.
- Use mode 2 for origin search.
- Recommended surge-absorbing diode: RU2 (Sanken Electric Co., Ltd.) or equivalent
- Connect signal lines so that the servo can be turned ON and OFF with the RUN signal.

Example 3: Connection with SYSMAC CS1W-NC133/233/433

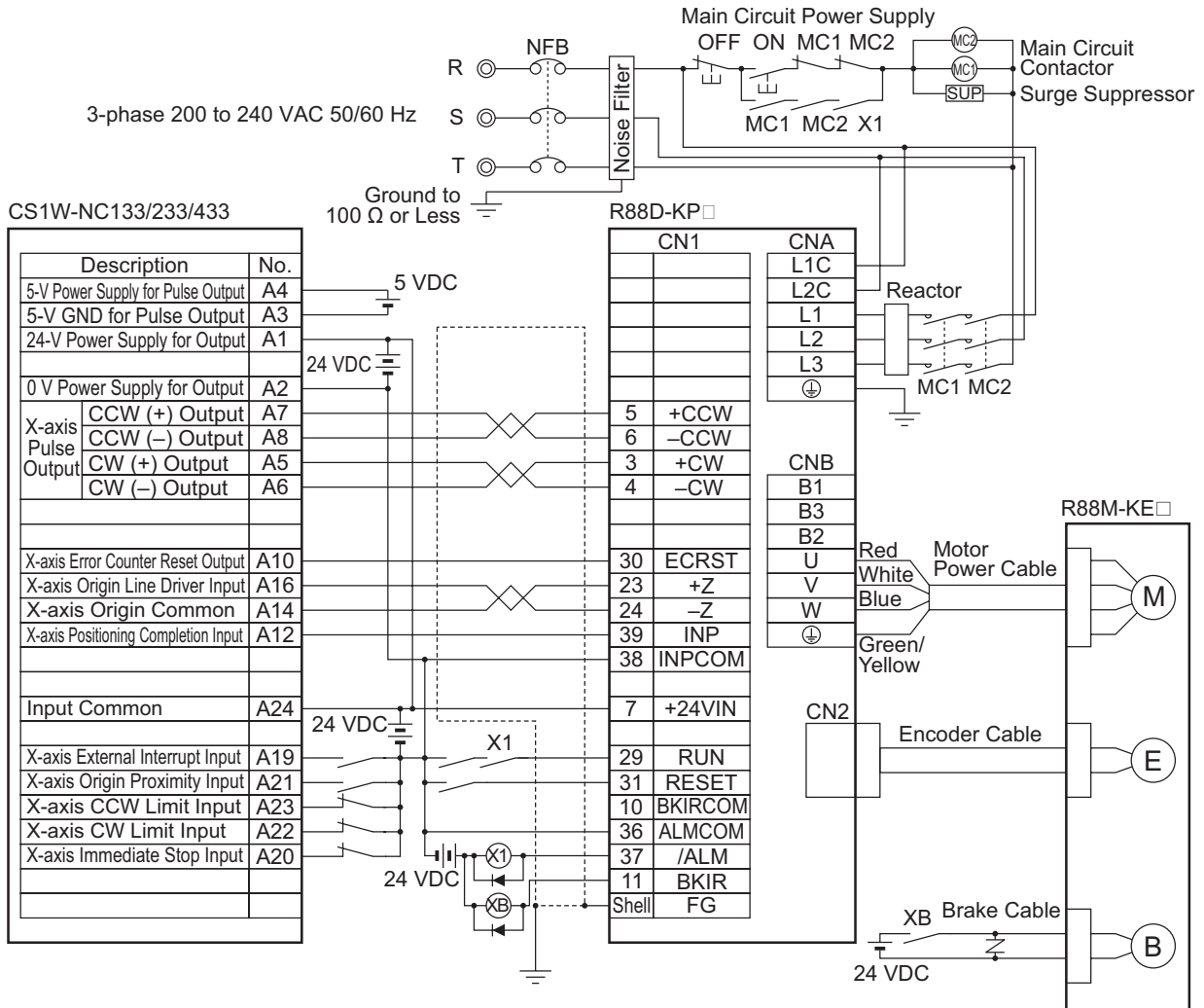

Precautions for Correct Use

- The above example shows an example of connecting a Servo Drive with 3-phase 200 VAC main circuit power supply inputs. Use a power supply and power cables that meet the power supply specifications of the Servo Drive.
- Note that incorrect connection of signal lines may cause damage to the Servo Drive and connected units.
- Leave unused signal wires disconnected and open.
- Use mode 2 for origin search.
- Recommended surge-absorbing diode: RU2 (Sanken Electric Co., Ltd.) or equivalent
- Connect signal lines so that the servo can be turned ON and OFF with the RUN signal.

Example 4: Connection with SYSMAC CS1W-NC113/213/413, C200HW-NC113/213/413

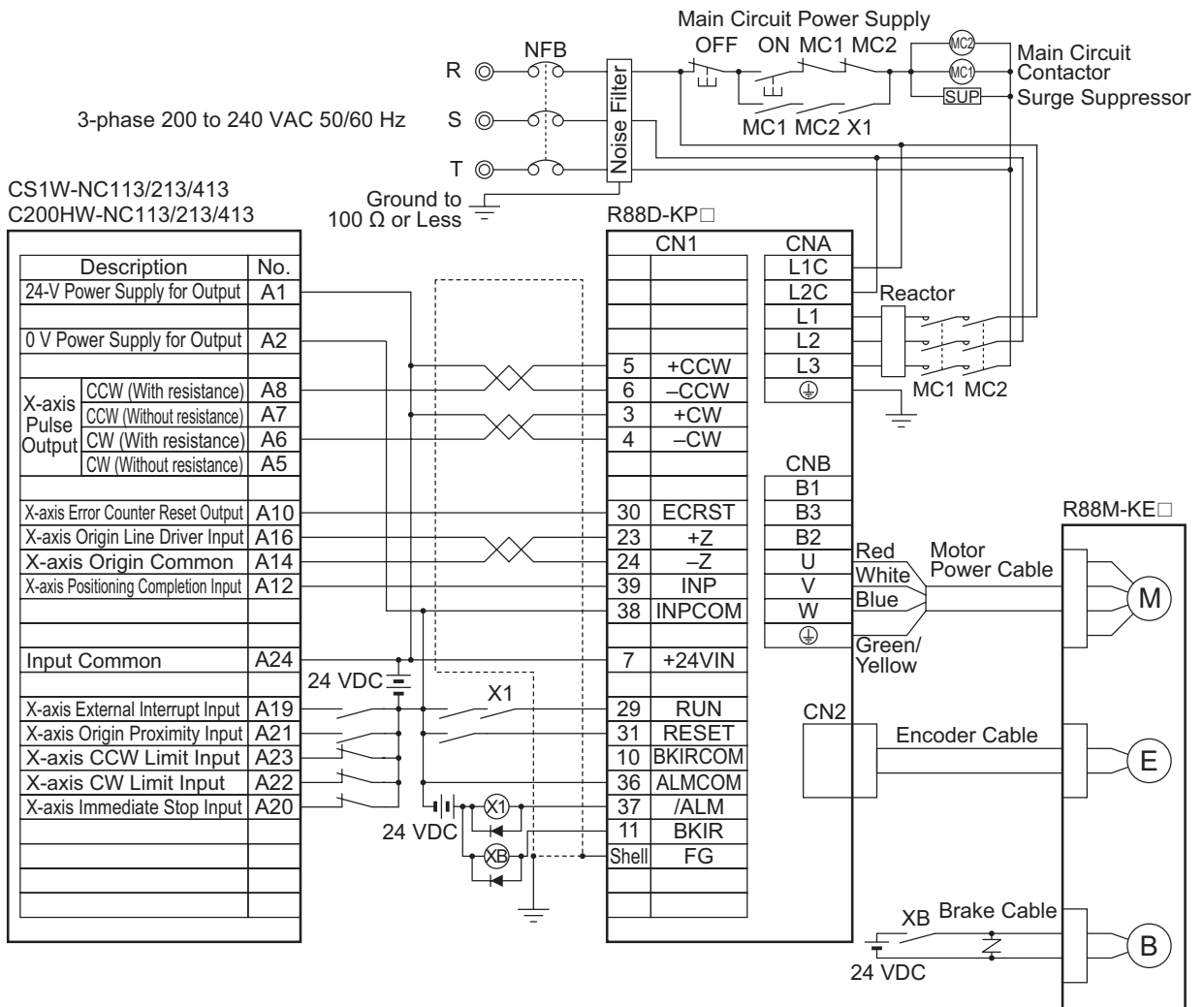

Precautions for Correct Use

- The above example shows an example of connecting a Servo Drive with 3-phase 200 VAC main circuit power supply inputs. Use a power supply and power cables that meet the power supply specifications of the Servo Drive.
- Note that incorrect connection of signal lines may cause damage to the Servo Drive and connected units.
- Leave unused signal wires disconnected and open.
- Use mode 2 for origin search.
- Recommended surge-absorbing diode: RU2 (Sanken Electric Co., Ltd.) or equivalent
- Connect signal lines so that the servo can be turned ON and OFF with the RUN signal.

Example 6: Connection with SYSMAC CP1H-X□□DT-D/CP1L-□□□DT-D

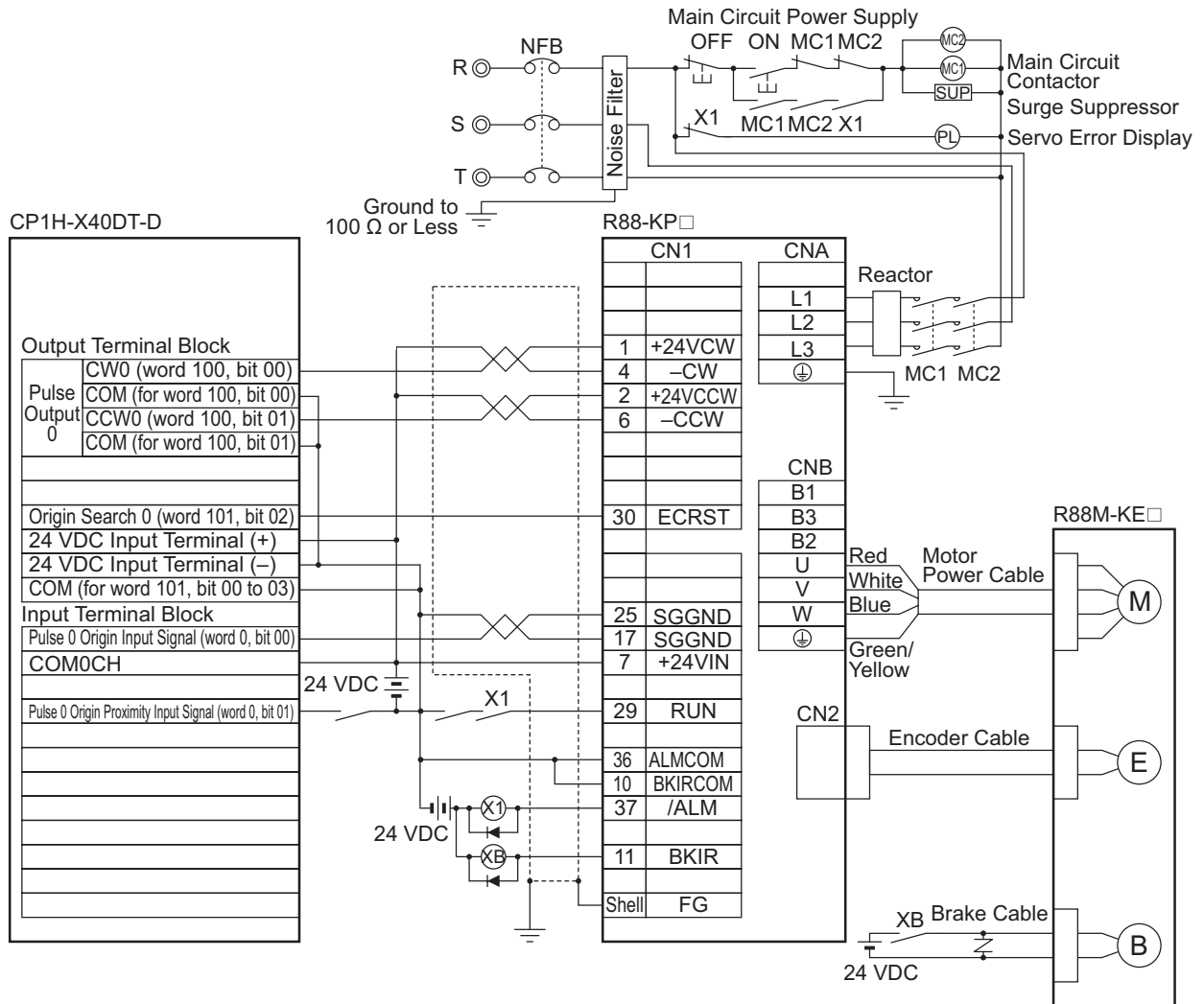

Precautions for Correct Use

- Note that incorrect connection of signal lines may cause damage to the Servo Drive and connected units.
- Leave unused signal wires disconnected and open.
- Use a separate power supply (24 VDC) for the brake, independent of the 24 VDC control power supply.
- Recommended surge-absorbing diode: RU2 (Sanken Electric Co., Ltd.) or equivalent

Example 8: Connection with SYSMAC Customizable Counter Unit CS1W-HCP22-V1

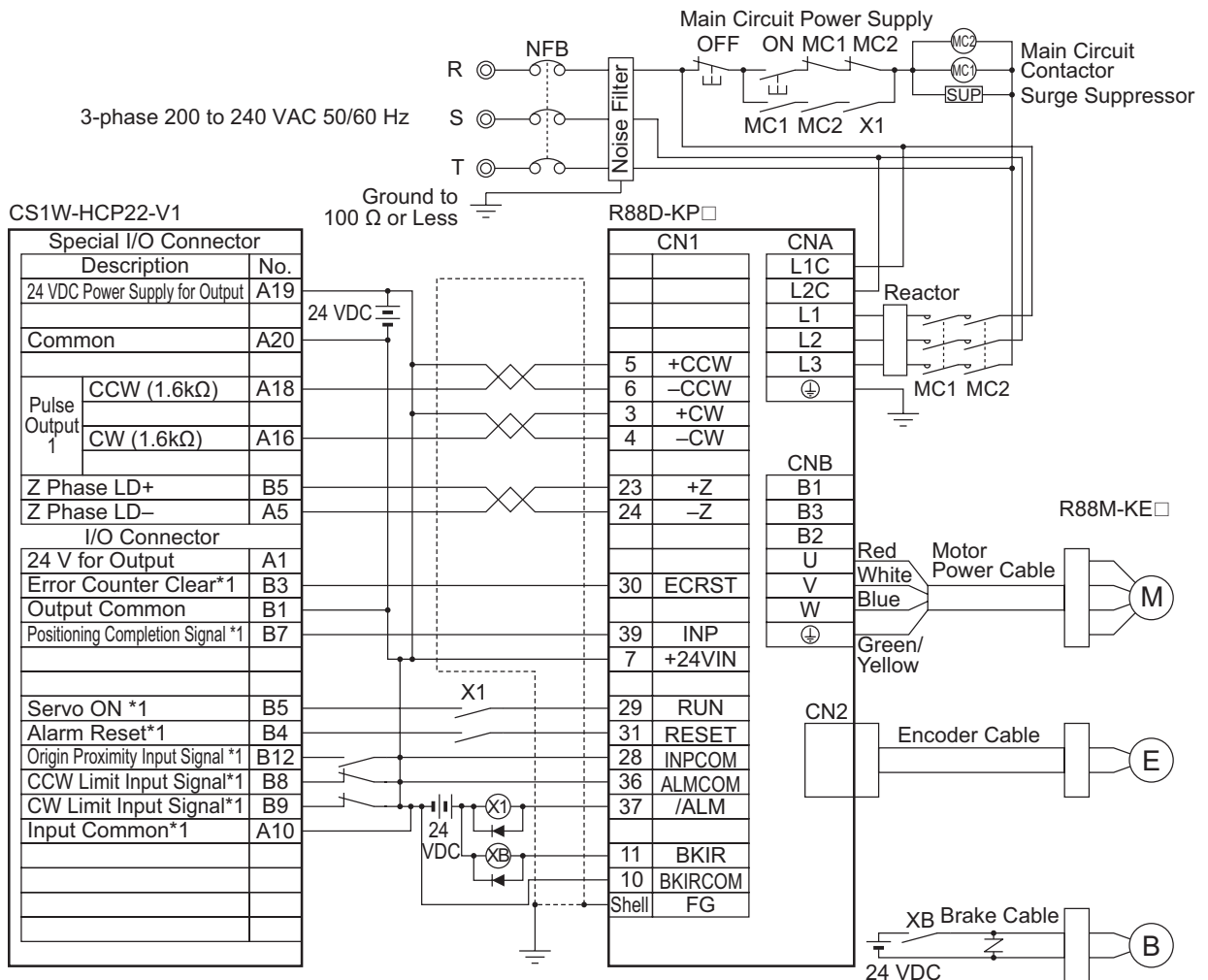

*1 The I/O signals for the HCP22 vary depending on the allocations of internal relay areas. Change the wiring according to the allocations.

Precautions for Correct Use

- Note that incorrect connection of signal lines may cause damage to the Servo Drive and connected units.
- Leave unused signal wires disconnected and open.
- Use a dedicated power supply (24 VDC) for the command pulse power.
- Recommended surge-absorbing diode: RU2 (Sanken Electric Co., Ltd.) or equivalent
- Use a separate power supply (24 VDC) for the brake, independent of the 24 VDC control power supply.

Example 9: Connection with SYSMAC Customizable Counter Unit CS1W-HCA12/22-V1

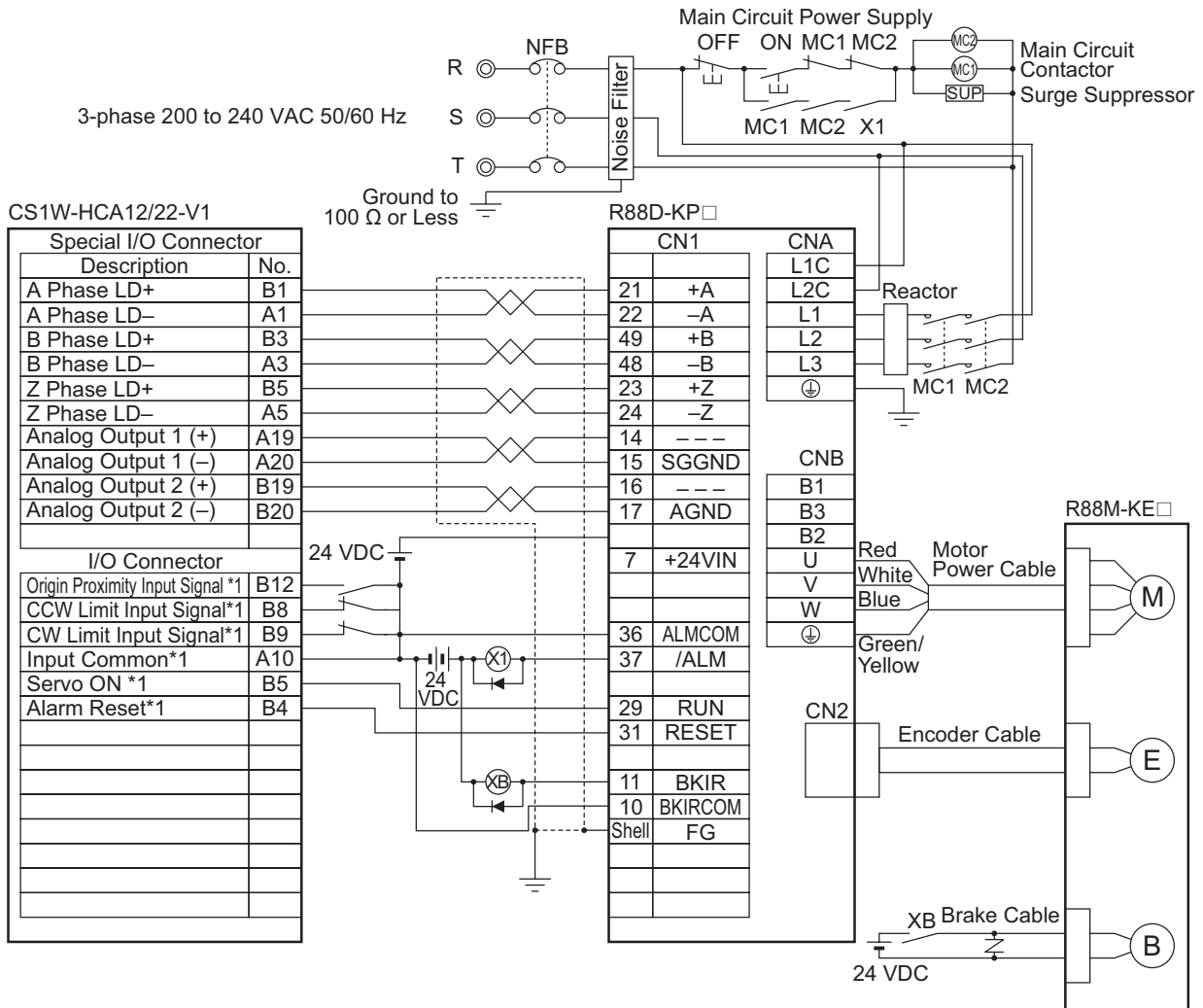

*1 The I/O signals for the HCA12/22 vary depending on the allocations in the internal relay area. Change the wiring according to the allocations.



Precautions for Correct Use

- Note that incorrect connection of signal lines may cause damage to the Servo Drive and connected units.
- Leave unused signal wires disconnected and open.
- Use a dedicated power supply (24 VDC) for the command pulse power.
- Recommended surge-absorbing diode: RU2 (Sanken Electric Co., Ltd.) or equivalent
- Use a separate power supply (24 VDC) for the brake, independent of the 24 VDC control power supply.

A-2 Parameter List

- Some parameters are enabled by cycling the power supply (shown in the tables below). After changing these parameters, turn OFF the power supply, confirm that the power supply indicator is not lit, and then turn ON the power supply again to restart the system.
- Do not change the parameters marked “Reserved.”
Do not change the set values marked “Not used” or “Reserved”.

A

Basic Setting Parameters

Pn No.	Name	Setting	Description	Default setting	Unit	Setting range	Cycle the power supply
000	Rotation Direction Setting	Set the relation between the command direction and the motor rotation direction.		1	-	0 to 1	Required
		0	Forward (CW) when viewed from shaft end for positive (+) commands				
		1	Reverse (CCW) when viewed from shaft end for positive (+) commands				
001	Control Mode Selection	Select the control mode of the Servo Drive.		0	-	0 to 3	Required
		0	Position control (Pulse-train command)				
		1	Speed control (Internally set speed control)				
		2	Reserved (Do not set.)				
		3	Mode 1: Position control Mode 2: Speed control				
		4	Reserved (Do not set.)				
		5	Reserved (Do not set.)				
6	Reserved (Do not set.)						
002	Realtime Autotuning Mode Selection	Set the realtime autotuning operation mode.		1	-	0 to 6	-
		0	Disabled				
		1	Focus on stability				
		2	Focus on position control				
		3	Used when an unbalanced load is present on a vertical axis etc.				
		4	Used when friction is large				
		5	Used when an unbalanced load is present on a vertical axis etc. and friction is large				
6	Used when customizing the realtime autotuning function						
003	Realtime Autotuning Machine Rigidity Setting	Set the machine rigidity when realtime autotuning is enabled.		13 ^{*1}	-	0 to 31	-
004	Inertia Ratio	Set the load inertia as a percentage of the motor rotor inertia.		250	%	0 to 10,000	-

Pn No.	Name	Setting	Description	Default setting	Unit	Setting range	Cycle the power supply
005	Command Pulse Input Selection	Select the command pulse input mode.		0	-	0 to 1	Required
		0	Photocoupler input				
		1	Input for line driver only				
006	Command Pulse Rotation Direction Switching Selection	Select the command pulse count direction.		0	-	0 to 1	Required
		0	Forward direction				
		1	Reverse direction				
007	Command Pulse Mode Selection	Set the command pulse mode.		1	-	0 to 3	Required
		0	90° phase difference (A/B) signal input				
		1	Forward pulse/Reverse pulse				
		2	90° phase difference (A/B) signal input				
		3	Feed pulse/Forward or reverse signal				
008	Electronic Gear Integer Setting	Set the number of command pulses per motor rotation.		10,000	Pulse	0 to 2 ²⁰	Required
009	Electronic Gear Ratio Numerator 1	Set the electronic gear ratio. If Pn009 = 0, the encoder resolution is set in the numerator.		0	-	0 to 2 ³⁰	-
010	Electronic Gear Ratio Denominator	$\frac{\text{Electronic Gear Ratio Numerator 1 (Pn009)}}{\text{Electronic Gear Ratio Denominator (Pn010)}}$		10,000	-	1 to 2 ³⁰	-
011	Encoder Dividing Numerator	Set the number of output pulses per motor rotation for phases A and B.		2,500	P/r	1 to 262,144	Required
012	Encoder Output Direction Switching Selection	Select the combination of the phase-B logic and the output source for pulse regeneration output.		0	-	0 to 1	Required
		0	Phase-B logic: Not reversed Output source: Encoder				
		1	Phase-B logic: Reversed Output source: Encoder				
		2	Reserved (Do not set.)				
		3	Reserved (Do not set.)				
013	No. 1 Torque Limit	Set the first output torque limit of the Servomotor.		500	%	0 to 500	-
014	Error Counter Overflow Level	Set the range of the error counter overflow level. Detection of error counter overflow level error is disabled if the set value is 0.		10,000	Command unit	0 to 2 ²⁷	-
015	Reserved	Do not set.		1	-	1	-
		1	Use as incremental encoder.				

Pn No.	Name	Setting	Description	Default setting	Unit	Setting range	Cycle the power supply
016	Regeneration Resistor Selection	Select the Regeneration Resistor to be used.		3*2	-	0 to 3	Required
		0	Uses the Built-in Resistor. The Regeneration Overload Protection (Alarm No.18) is enabled according to the Built-in Resistor (with approx. 1% duty).				
		1	Uses the External Resistor. The regeneration processing circuit operates and Regeneration Overload Protection (Alarm No.18) is enabled when the operating rate of the Regeneration Resistor is over 10%.				
		2	Uses the External Resistor. Regeneration Overload Protection (Alarm No.18) is disabled.				
		3	No Regeneration Resistors. All regenerative energy is processed by the built-in capacitor.				
017	External Regeneration Resistor Setting	Select the load ratio calculation type for the External Regeneration Resistor.		0	-	0	Required
		0	Regeneration load ratio is 100% when the operating rate of the External Regeneration Resistor is 10%.				
		1	Reserved				
		2	Reserved				
		3	Reserved				
		4	Reserved				

*1 The default setting is 11 for a Servo Drive with 200 V and 1 kW or more.

*2 The default setting is 0 for a Servo Drive with 200 V and 750 W or more.

Gain Adjustment Parameters

Pn No.	Name	Setting	Description	Default setting	Unit	Setting range	Cycle the power supply
100	Position Loop Gain		Set the first position loop gain.	480 ^{*1}	0.1/s	0 to 30,000	–
101	Speed Loop Gain		Set the first speed loop gain.	270 ^{*2}	0.1 Hz	1 to 32,767	–
102	Speed Loop Integral Time Constant		Set the first speed loop integral time constant.	210 ^{*3}	0.1 ms	1 to 10,000	–
103	Speed Feedback Filter Time Constant		Set the first speed feedback filter in six levels.	0	–	0 to 5	–
104	Torque Command Filter Time Constant		Set the first torque filter time constant.	84 ^{*4}	0.01 ms	0 to 2,500	–
105	Position Loop Gain 2		Set the second position loop gain.	570 ^{*5}	0.1/s	0 to 30,000	–
106	Speed Loop Gain 2		Set the second speed loop gain.	270 ^{*6}	0.1 Hz	1 to 32,767	–
107	Speed Loop Integral Time Constant 2		Set the second speed loop integral time constant.	10,000	0.1 ms	1 to 10,000	–
108	Speed Feedback Filter Time Constant 2		Set the second speed feedback filter in six levels.	0	–	0 to 5	–
109	Torque Command Filter Time Constant 2		Set the second torque filter time constant.	84 ^{*7}	0.01 ms	0 to 2,500	–
110	Speed Feed-forward Amount		Set the speed feed-forward amount.	300	0.1%	0 to 1,000	–
111	Speed Feed-forward Command Filter		Set the speed feed-forward filter time constant.	50	0.01 ms	0 to 6,400	–
112	Torque Feed-forward Amount		Set the torque feed-forward amount.	0	0.1%	0 to 1,000	–
113	Torque Feed-forward Command Filter		Set the torque feed-forward filter.	0	0.01 ms	0 to 6,400	–
114	Gain Switching Input Operating Mode Selection		Set this parameter if the gain switching function is used for optimal tuning.	1	–	0 to 1	–
		0	Gain 1 (PI/P switching is enabled)				
		1	Gain 1/Gain 2 switching is enabled				

Pn No.	Name	Setting	Description	Default setting	Unit	Setting range	Cycle the power supply
115	Switching Mode in Position Control	Select the conditions for switching the position control gain. Pn114 must be set to 1.		0	-	0 to 10	-
		0	Always Gain 1				
		1	Always Gain 2				
		2	Switching using gain switching input (GSEL)				
		3	Amount of change in torque command				
		4	Always Gain 1				
		5	Command speed				
		6	Amount of position error				
		7	Command pulse input				
		8	Positioning completion output (INP) OFF				
		9	Actual motor speed				
10	Combination of command pulse input and motor speed						
116	Gain Switching Delay Time in Position Control	Set the delay time when switching from Gain 2 to Gain 1.		50	0.1 ms	0 to 10,000	-
117	Gain Switching Level in Position Control	Set the gain switching level.		50	-	0 to 20,000	-
118	Gain Switching Hysteresis in Position Control	Set the hysteresis in gain switching.		33	-	0 to 20,000	-
119	Position Gain Switching Time	Set the position gain switching time in gain switching.		33	0.1 ms	0 to 10,000	-
120	Switching Mode in Speed Control	Select the conditions for switching the speed control gain. Pn114 must be set to 1.		0	-	0 to 5	-
		0	Always Gain 1				
		1	Always Gain 2				
		2	Switching using gain switching input (GSEL)				
		3	Amount of change in torque command				
		4	Amount of change in speed command				
5	Command speed						
121	Gain Switching Delay Time in Speed Control	Set the delay time when switching from Gain 2 to Gain 1.		0	0.1 ms	0 to 10,000	-
122	Gain Switching Level in Speed Control	Set the gain switching level.		0	-	0 to 20,000	-
123	Gain Switching Hysteresis in Speed Control	Set the hysteresis in gain switching.		0	-	0 to 20,000	-
124	Reserved	Do not set.		0	-	0	-

Pn No.	Name	Setting	Description	Default setting	Unit	Setting range	Cycle the power supply
125	Reserved	Do not set.		0	–	0	–
126	Reserved	Do not set.		0	–	0	–
127	Reserved	Do not set.		0	–	0	–

- *1 The default setting is 320 for a Servo Drive with 200 V and 1 kW or more.
- *2 The default setting is 180 for a Servo Drive with 200 V and 1 kW or more.
- *3 The default setting is 310 for a Servo Drive with 200 V and 1 kW or more.
- *4 The default setting is 126 for a Servo Drive with 200 V and 1 kW or more.
- *5 The default setting is 380 for a Servo Drive with 200 V and 1 kW or more.
- *6 The default setting is 180 for a Servo Drive with 200 V and 1 kW or more.
- *7 The default setting is 126 for a Servo Drive with 200 V and 1 kW or more.

Vibration Suppression Function Parameters

Pn No.	Name	Setting	Description	Default setting	Unit	Setting range	Cycle the power supply
200	Adaptive Filter Selection	Set the operation of the adaptive filter.		0	-	0 to 4	-
		0	Disabled				
		1	One filter enabled. Frequency limit applied when enabled.				
		2	Two filters enabled. Frequency limit applied when enabled.				
		3	One filter always enabled.				
4	Two filters enabled, one of which is always enabled.						
201	Notch 1 Frequency Setting	Set the notch frequency of the first resonance suppression notch filter.		5,000	Hz	50 to 5,000	-
202	Notch 1 Width Setting	Set the notch width of the first resonance suppression notch filter.		2	-	0 to 20	-
203	Notch 1 Depth Setting	Set the notch depth of the first resonance suppression notch filter.		0	-	0 to 99	-
204	Notch 2 Frequency Setting	Set the notch frequency of the second resonance suppression notch filter.		5,000	Hz	50 to 5,000	-
205	Notch 2 Width Setting	Set the notch width of the second resonance suppression notch filter.		2	-	0 to 20	-
206	Notch 2 Depth Setting	Set the notch depth of the second resonance suppression notch filter.		0	-	0 to 99	-
207	Notch 3 Frequency Setting	Set the notch frequency of the third resonance suppression notch filter. This parameter is automatically set when the adaptive filter is enabled.		5,000	Hz	50 to 5,000	-
208	Notch 3 Width Setting	Set the notch width of the third resonance suppression notch filter. This parameter is automatically set when the adaptive filter is enabled.		2	-	0 to 20	-
209	Notch 3 Depth Setting	Set the notch depth of the third resonance suppression notch filter. This parameter is automatically set when the adaptive filter is enabled.		0	-	0 to 99	-
210	Notch 4 Frequency Setting	Set the notch frequency of the fourth resonance suppression notch filter. This parameter is automatically set when the adaptive filter is enabled.		5,000	Hz	50 to 5,000	-
211	Notch 4 Width Setting	Set the notch width of the fourth resonance suppression notch filter. This parameter is automatically set when the adaptive filter is enabled.		2	-	0 to 20	-
212	Notch 4 Depth Setting	Set the notch depth of the fourth resonance suppression notch filter. This parameter is automatically set when the adaptive filter is enabled.		0	-	0 to 99	-

Pn No.	Name	Setting	Description	Default setting	Unit	Setting range	Cycle the power supply
213	Damping Filter Selection	Set the switching method for damping filters.		0	-	0 to 3	-
		0	Enabled				
		1	When DF-SEL1 input is open: Damping filters 1 and 3 enabled When DF-SEL1 input is shorted: Damping filters 2 and 4 enabled				
		2	When both DF-SEL1 and DF-SEL2 are open: Damping filter 1 enabled When DF-SEL1 is shorted and DF-SEL2 is open: Damping filter 2 enabled When DF-SEL1 is open and DF-SEL2 is shorted: Damping filter 3 enabled When both DF-SEL1 and DF-SEL2 are shorted: Damping filter 4 enabled				
		3	Forward direction: Damping filters 1 and 3 enabled Reverse direction: Damping filters 2 and 4 enabled				
214	Damping Frequency 1	Set the first damping frequency. The minimum allowable setting is 10 (= 1 Hz).		0	0.1 Hz	0 to 2,000	-
215	Damping Filter 1 Setting	Make fine adjustment to the first damping control function. Set a smaller value if torque saturation occurs or a larger value to increase the responsiveness.		0	0.1 Hz	0 to 1,000	-
216	Damping Frequency 2	Set the second damping frequency. The minimum allowable setting is 10 (= 1 Hz).		0	0.1 Hz	0 to 2,000	-
217	Damping Filter 2 Setting	Make fine adjustment to the second damping control function. Set a smaller value if torque saturation occurs or a larger value to increase the responsiveness.		0	0.1 Hz	0 to 1,000	-
218	Damping Frequency 3	Set the third damping frequency. The minimum allowable setting is 10 (= 1 Hz).		0	0.1 Hz	0 to 2,000	-
219	Damping Filter 3 Setting	Make fine adjustment to the third damping control function. Set a smaller value if torque saturation occurs or a larger value to increase the responsiveness.		0	0.1 Hz	0 to 1,000	-
220	Damping Frequency 4	Set the fourth damping frequency. The minimum allowable setting is 10 (= 1 Hz).		0	0.1 Hz	0 to 2,000	-
221	Damping Filter 4 Setting	Make fine adjustment to the fourth damping control function. Set a smaller value if torque saturation occurs or a larger value to increase the responsiveness.		0	0.1 Hz	0 to 1,000	-
222	Position Command Filter Time Constant	Set the first-order lag filter time constant for the position command.		0	0.1 ms	0 to 10,000	-
223	Smoothing Filter Time Constant	Set the FIR filter time constant for the position command.		0	0.1 ms	0 to 10,000	-

Speed Control Parameters

Pn No.	Name	Setting	Description	Default setting	Unit	Setting range	Cycle the power supply
300	Command Speed Selection	Select the speed command in the speed control mode.		1	-	1 to 3	-
		0	Disabled				
		1	No. 1 Internally Set Speed to No. 4 Internally Set Speed (Pn304 to Pn307)				
		2	Reserved (Do not set.)				
301	Speed Command Direction Selection	Select the method to specify the speed command direction.		0	-	0 to 1	-
		0	By a sign				
		1	By VSIGN				
302	Reserved	Do not set.		500	-	500	-
303	Reserved	Do not set.		1	-	1	-
304	No. 1 Internally Set Speed	Set the first internal speed command value.		0	r/min	-20,000 to 20,000	-
305	No. 2 Internally Set Speed	Set the second internal speed command value.		0	r/min		-
306	No. 3 Internally Set Speed	Set the third internal speed command value.		0	r/min		-
307	No. 4 Internally Set Speed	Set the fourth internal speed command value.		0	r/min		-
308	No. 5 Internally Set Speed	Set the fifth internal speed command value.		0	r/min		-
309	No. 6 Internally Set Speed	Set the sixth internal speed command value.		0	r/min		-
310	No. 7 Internally Set Speed	Set the seventh internal speed command value.		0	r/min		-
311	No. 8 Internally Set Speed	Set the eighth internal speed command value.		0	r/min		-
312	Soft Start Acceleration Time	Set the acceleration time relative to the speed command.		0	ms/ (1,000 r/min)	0 to 10,000	-
313	Soft Start Deceleration Time	Set the deceleration time relative to the speed command.		0	ms/ (1,000 r/min)	0 to 10,000	-
314	S-curve Acceleration/Deceleration Time Setting	Set the acceleration or deceleration S-curve time for the speed command.		0	ms	0 to 1,000	-

Pn No.	Name	Setting	Description	Default setting	Unit	Setting range	Cycle the power supply
315	Zero Speed Designation Selection	Select the zero speed designation input (ZEROSPD) function.		0	-	0 to 3	-
		0	Disabled				
		1	Sets the speed command value to 0.				
		2	Sets the speed command value to 0 and causes a servo lock if the actual speed reaches 0 or less.				
		3	Sets the speed command value to 0 and causes a servo lock if the speed command value reaches the value set in Zero Speed or less.				
316	Position Lock Level Setting	Set the threshold for transition to the position lock mode.		30	r/min	10 to 20,000	-
317	Reserved	Do not set.		0	-	0	-
318	Reserved	Do not set.		0	-	0	-
319	Reserved	Do not set.		30	-	30	-
320	Reserved	Do not set.		0	-	0	-
321	Reserved	Do not set.		0	-	0	-
322	Reserved	Do not set.		0	-	0	-
323	Reserved	Do not set.		0	-	0	-
324	Reserved	Do not set.		0	-	0	-
325	Reserved	Do not set.		10,000	-	10,000	-
326	Reserved	Do not set.		0	-	0	-
327	Reserved	Do not set.		0	-	0	-
328	Reserved	Do not set.		16,000	-	16,000	-
329	Reserved	Do not set.		0	-	0	-

Interface Monitor Setting Parameters

Pn No.	Name	Setting	Description	Default setting	Unit	Setting range	Cycle the power supply
400	Input Signal Selection 1	Set the function and logic of input signal 1.		8,553,090	-	0 to 00FFFFFF hex	Required
401	Input Signal Selection 2	Set the function and logic of input signal 2.		8,487,297	-	0 to 00FFFFFF hex	Required
402	Input Signal Selection 3	Set the function and logic of input signal 3.		9,539,850	-	0 to 00FFFFFF hex	Required
403	Input Signal Selection 4	Set the function and logic of input signal 4.		394,758	-	0 to 00FFFFFF hex	Required
404	Input Signal Selection 5	Set the function and logic of input signal 5.		4,108	-	0 to 00FFFFFF hex	Required
405	Input Signal Selection 6	Set the function and logic of input signal 6.		197,379	-	0 to 00FFFFFF hex	Required

Pn No.	Name	Setting	Description	Default setting	Unit	Setting range	Cycle the power supply
406	Input Signal Selection 7		Set the function and logic of input signal 7.	3,847	–	0 to 00FFFFFF hex	Required
407	Input Signal Selection 8		Set the function and logic of input signal 8.	263,172	–	0 to 00FFFFFF hex	Required
408	Input Signal Selection 9		Set the function and logic of input signal 9.	328,965	–	0 to 00FFFFFF hex	Required
409	Input Signal Selection 10		Set the function and logic of input signal 10.	3,720	–	0 to 00FFFFFF hex	Required
410	Output Signal Selection 1		Set the function assignment of output signal 1.	197,379	–	0 to 00FFFFFF hex	Required
411	Output Signal Selection 2		Set the function assignment of output signal 2.	131,586	–	0 to 00FFFFFF hex	Required
412	Not used		Do not change the set value.	–	–	–	–
413	Output Signal Selection 4		Set the function assignment of output signal 4.	328,964	–	0 to 00FFFFFF hex	Required
416	Analog Monitor 1 Selection	Select the type of analog monitor 1.		0	–	0 to 21	–
		0	Motor speed				
		1	Position command speed				
		2	Internal position command speed				
		3	Speed control command				
		4	Torque command				
		5	Position command error				
		6	Encoder position error				
		7	Reserved (Do not set.)				
		8	Reserved (Do not set.)				
		9	P-N voltage				
		10	Regeneration load ratio				
		11	Overload load ratio				
		12	Forward direction torque limit				
		13	Reverse direction torque limit				
		14	Speed limit value				
		15	Inertia ratio				
		16	Reserved (Do not set.)				
		17	Reserved (Do not set.)				
		18	Reserved (Do not set.)				
		19	Encoder temperature				
		20	Drive temperature				
21	Encoder 1-rotation data						
417	Analog Monitor 1 Scale Setting		Set the output gain of the analog monitor 1.	0	–	0 to 214,748,364	–

Pn No.	Name	Setting	Description	Default setting	Unit	Setting range	Cycle the power supply
418	Analog Monitor 2 Selection		Select the type of analog monitor 2. The set values for this parameter are the same as those of Analog Monitor 1 Selection (Pn416).	4	–	0 to 21	–
419	Analog Monitor 2 Scale Setting		Select the output gain of the analog monitor 2.	0	–	0 to 214,748,364	–
421	Analog Monitor Output Setting		Select the analog monitor output voltage method.	0	–	0 to 2	–
		0	Output range: –10 to 10 V Data output: Positive or negative				
		1	Output range: 0 to 10 V Data output: Positive or negative				
		2	Output range: 0 to 10 V Data output: Positive or negative				
422	Reserved		Do not set.	0	–	0	–
423	Reserved		Do not set.	0	–	0	–
424	Reserved		Do not set.	0	–	0	–
425	Reserved		Do not set.	0	–	0	–
426	Reserved		Do not set.	0	–	0	–
427	Reserved		Do not set.	0	–	0	–
428	Reserved		Do not set.	0	–	0	–
429	Reserved		Do not set.	0	–	0	–
430	Reserved		Do not set.	0	–	0	–
431	Positioning Completion Range 1		Set the positioning completion range as the number of allowable pulses.	10	Command unit	0 to 262,144	–
432	Positioning Completion Condition Selection		Select the judgment condition for the positioning completion output.	0	–	0 to 3	–
		0	The positioning completion output turns ON when the position error is equal to or less than Positioning Completion Range 1 (Pn431).				
		1	The positioning completion output turns ON when there is no position command and the position error is equal to or less than Positioning Completion Range 1 (Pn431).				
		2	The positioning completion output turns ON when there is no position command, the zero speed detection signal is ON, and the position error is equal to or less than Positioning Completion Range 1 (Pn431).				
		3	The positioning completion output turns ON when there is no position command and the position error is equal to or less than Positioning Completion Range 1 (Pn431). After that, the ON state will be retained until the next position command is received.				

Pn No.	Name	Setting	Description	Default setting	Unit	Setting range	Cycle the power supply
433	Positioning Completion Hold Time		Set the positioning completion hold time.	0	1 ms	0 to 30,000	–
434	Zero Speed Detection		Set the threshold for the zero speed detection signal (ZSP).	50	r/min	10 to 20,000	–
435	Speed Conformity Detection Range		Set the threshold for detecting the Speed Conformity Output Signal (VCMP) signal as the difference between the speed command value and the actual speed.	50	r/min	10 to 20,000	–
436	Rotation Speed for Motor Rotation Detection		Set the threshold for detecting the Motor Rotation Speed Detection Output (TGON).	1,000	r/min	10 to 20,000	–
437	Brake Timing when Stopped		Set the time elapsed until the mechanical brake is activated when the Servomotor is stopped.	0	1 ms	0 to 10,000	–
438	Brake Timing During Operation		Set the time elapsed until the mechanical brake is activated when the Servomotor is operating.	0	1 ms	0 to 10,000	–
439	Brake Release Speed Setting		Set the threshold speed for judging whether to output the mechanical brake release signal when the Servomotor is operating.	30	r/min	30 to 3,000	–
440	Warning Output Selection 1		Select the type of warning to be output from Warning Output 1.	0	–	0 to 10	–
		0	OR output for all types of warnings				
		1	Overload warning				
		2	Excessive regeneration warning				
		3	Battery warning				
		4	Fan warning				
		5	Encoder communications warning				
		6	Encoder overheating warning				
		7	Vibration detection warning				
		8	Service life detection warning				
		9	Reserved (Do not set.)				
10	Reserved (Do not set.)						
441	Warning Output Selection 2		Select the type of warning to be output from Warning Output 2. For this parameter, set the same value as for Warning Output Selection 1 (Pn440).	0	–	0 to 10	–
442	Positioning Completion Range 2		Set the second positioning completion range as the number of allowable pulses.	10	Command unit	0 to 262,144	–

Expansion Setting Parameters

Pn No.	Name	Setting	Description	Default setting	Unit	Setting range	Cycle the power supply
500	Electronic Gear Ratio Numerator 2		Set the electronic gear ratio. If Pn500, Pn501, or Pn502 = 0, the encoder resolution is set in the numerator.	0	–	0 to 2 ³⁰	–
501	Electronic Gear Ratio Numerator 3		Electronic Gear Ratio Numerator 2 (Pn500) or Electronic Gear Ratio Numerator 3 (Pn501) or Electronic Gear Ratio Numerator 4 (Pn502) Electronic Gear Ratio Denominator (Pn010)	0	–	0 to 2 ³⁰	–
502	Electronic Gear Ratio Numerator 4			0	–	0 to 2 ³⁰	–
503	Encoder Dividing Denominator			Set the denominator if the number of pulses per motor rotation is not an integer in pulse regeneration.	0	–	0 to 262,144
504	Drive Prohibition Input Selection		Set the operation to be performed upon forward/reverse drive prohibition input.	1	–	0 to 2	Required
		0	Forward or reverse drive prohibition input enabled				
		1	Forward or reverse drive prohibition input disabled				
		2	Forward or reverse drive prohibition input enabled				
505	Stop Selection for Drive Prohibition Input		Make the setting upon drive prohibition input.	0	–	0 to 2	Required
		0	The torque in the drive prohibit direction is disabled, and the dynamic brake is activated.				
		1	The torque in the drive prohibit direction is disabled, and free-run deceleration is performed.				
		2	The torque in the drive prohibit direction is disabled, and an immediate stop is performed.				

Pn No.	Name	Setting	Description	Default setting	Unit	Setting range	Cycle the power supply
506	Stop Selection with Servo OFF	Set the stop operation to be performed when the servo is OFF.		0	-	0 to 9	-
		0	During deceleration: Dynamic brake After stopping: Dynamic brake Error counter: Clear				
		1	During deceleration: Free-run After stopping: Dynamic brake Error counter: Clear				
		2	During deceleration: Dynamic brake After stopping: Servo-free Error counter: Clear				
		3	During deceleration: Free-run After stopping: Servo-free Error counter: Clear				
		4	During deceleration: Dynamic brake After stopping: Dynamic brake Error counter: Hold				
		5	During deceleration: Free-run After stopping: Dynamic brake Error counter: Hold				
		6	During deceleration: Dynamic brake After stopping: Servo-free Error counter: Hold				
		7	During deceleration: Free-run After stopping: Servo-free Error counter: Hold				
		8	During deceleration: Emergency stop After stopping: Dynamic brake Error counter: Clear				
9	During deceleration: Emergency stop After stopping: Servo-free Error counter: Clear						
507	Stop Selection with Main Power Supply OFF	Set the stop operation to be performed when the main power supply is turned OFF. The set values for this parameter are the same as those of Stop Selection with Servo OFF (Pn506).		0	-	0 to 9	-
508	Undervoltage Alarm Selection	Select whether to allow an LV trip or turn OFF the servo when a main power supply alarm occurs.		1	-	0 to 1	-
509	Momentary Hold Time	Set the Main Power Supply Alarm detection time.		70	1 ms	70 to 2,000	Required

Pn No.	Name	Setting	Description	Default setting	Unit	Setting range	Cycle the power supply
510	Stop Selection for Alarm Detection	Set the operation sequence in case of an alarm.		0	-	0 to 7	-
		0	During deceleration: Dynamic brake After stopping: Dynamic brake				
		1	During deceleration: Free-run After stopping: Dynamic brake				
		2	During deceleration: Dynamic brake After stopping: Servo-free				
		3	During deceleration: Free-run After stopping: Servo-free				
		4	During deceleration by immediate stop alarm: Immediate stop During deceleration: Dynamic brake After stopping: Dynamic brake				
		5	During deceleration by immediate stop alarm: Immediate stop During deceleration: Free-run After stopping: Dynamic brake				
		6	During deceleration by immediate stop alarm: Immediate stop During deceleration: Dynamic brake After stopping: Servo-free				
7	During deceleration by immediate stop alarm: Immediate stop During deceleration: Free-run After stopping: Servo-free						
511	Immediate Stop Torque	Set the torque limit for immediate stop.		0	%	0 to 500	-
512	Overload Detection Level Setting	Set the overload detection level.		0	%	0 to 500 ^{*1}	-
513	Overspeed Detection Level Setting	Set the overspeed error detection level.		0	r/min	0 to 20,000	-
514	Overrun Limit Setting	Set the amount of Servomotor overrun for the position command.		10	0.1 rotation	0 to 1,000	-
515	Control Input Signal Read Setting	Select the signal read cycle for the interface from the following four levels.		0	-	0 to 3	Required
		0	0.166 ms				
		1	0.333 ms				
		2	1 ms				
		3	1.666 ms				
516	Alarm Reset Condition Setting	Set the alarm clear input detection method.		0	-	0 to 1	Required
		0	120 ms				
		1	Follow the setting of Control Input Signal Read Setting (Pn515).				

*1 The value is regarded as 115% if set to 115 or higher.

Pn No.	Name	Setting	Description	Default setting	Unit	Setting range	Cycle the power supply
517	Error Counter Reset Condition Selection	Set the condition for clearing the Error Counter Reset Input signal.		3	-	0 to 4	-
		0	Disabled				
		1	Clear the error counter with the level. (Shorted for 500 μs or longer)				
		2	Clear the error counter with the level. (Shorted for 1 ms or longer)				
		3	Clear the error counter with the edge. (Change from open to shorted for 100 μs or longer)				
		4	Clear the error counter with the edge. (Change from open to shorted 1 ms or longer)				
518	Command Pulse Prohibition Input Setting	Set whether to enable or disable the command pulse prohibition input signal (INH).		1	-	0 to 1	-
		0	Enabled				
		1	Disabled				
519	Command Pulse Prohibition Input Read Setting	Select the signal read cycle for the Command Pulse Prohibition Input.		0	-	0 to 4	Required
		0	0.166 ms				
		1	0.333 ms				
		2	1 ms				
		3	1.666 ms				
		4	0.166 ms				
520	Position Setting Unit Selection	Select the setting unit of Position Completion Range 1/2 and Error Counter Overflow Level.		0	-	0 to 1	Required
		0	Command unit				
		1	Encoder unit				
521	Torque Limit Selection	Select the forward or reverse torque limit selection method.		1	-	0 to 6	-
		0	Reserved (Do not set.)				
		1	Limit in both forward and reverse directions set in Pn013				
		2	Forward: Set in Pn013, Reverse: Set in Pn522				
		3	When TL-SEL input is open: Set in Pn013 When TL-SEL input is shorted: Set in Pn522				
		4	Reserved (Do not set.)				
		5	Reserved (Do not set.)				
		6	When TL-SEL input is open: Limit in forward direction set in Pn013, limit in reverse direction set in Pn522 When TL-SEL input is shorted: Limit in forward direction set in Pn525, limit in reverse direction set in Pn526				
522	No. 2 Torque Limit	Set the second output torque limit of the Servomotor.		500	%	0 to 500	-

Pn No.	Name	Setting	Description	Default setting	Unit	Setting range	Cycle the power supply
523	Torque Limit Switching Setting 1		Set the rate of change (fluctuation) when switching from No. 1 Torque Limit to No. 2 Torque Limit.	0	ms/100%	0 to 4,000	–
524	Torque Limit Switching Setting 2		Set the rate of change (fluctuation) when switching from No. 2 Torque Limit to No. 1 Torque Limit.	0	ms/100%	0 to 4,000	–
525	Forward External Torque Limit		Set the forward torque limit for TL-SEL input when Torque Limit Selection (Pn521) is set to 6.	500	%	0 to 500	–
526	Reverse External Torque Limit		Set the reverse torque limit for TL-SEL input when Torque Limit Selection (Pn521) is set to 6.	500	%	0 to 500	–
527	Reserved		Do not set.	30	–	30	–
528	Default Display		Select the type of data to be displayed by default on the 7-segment display when the control power supply is powered on.	1		0 to 35	Required
		0	Position command error		Command unit		
		1	Motor speed		r/min		
		2	Position command speed		r/min		
		3	Speed control command		r/min		
		4	Torque command		%		
		5	Total encoder pulses		Pulse		
		6	Total command pulses		Pulse		
		8	Reserved (Do not set.)		–		
		9	Control mode		–		
		10	I/O signal status		–		
		11	Reserved (Do not set.)		–		
		12	Alarm factor, history		–		
		13	Warning number		–		
		14	Regeneration resistance load ratio		%		
		15	Overload load ratio		%		
		16	Inertia ratio		%		
		17	Reason for no rotation		–		
		18	Display of the number of I/O signal changes		time		
		20	Reserved (Do not set.)		–		
		21	Reserved (Do not set.)		–		
		22	Monitor for the number of encoder communications errors		time		
		23	Reserved (Do not set.)		–		
		24	Position error (for each encoder)		–		
		25	Reserved (Do not set.)		–		
		26	Reserved (Do not set.)		–		
		27	P-N voltage		V		
		28	Software version		–		

Pn No.	Name	Setting	Description	Default setting	Unit	Setting range	Cycle the power supply
528	Default Display	29	Drive serial number	1	–	0 to 35	Required
		30	Motor serial number		–		
		31	Accumulative operation time		h		
		32	Automatic motor recognition function		–		
		33	Temperature information		°C		
		35	Reserved (Do not set.)		–		
531	Reserved	Do not set.		1	–	1	–
532	Command Pulse Input Maximum Setting	Set the maximum command pulse input value.		4,000	kpps	250 to 4,000	Required
533	Pulse Regeneration Output Limit Setting	Set whether to enable or disable the pulse regeneration limit error detection function.		0	–	0 to 1	Required
		0	Disabled				
		1	Enabled				
535	Front Key Protection Setting	Set whether or not to restrict operations on the front panel.		0	–	0 to 1	Required
		0	Operations not restricted				
		1	Operations restricted				

Special Setting Parameters

Pn No.	Name	Setting	Description	Default setting	Unit	Setting range	Cycle the power supply
600	Reserved	Do not set.		0	–	0	–
602	Excessive Speed Error Setting	Set the detection level for the speed deviation, which is the difference between the internal position command speed and the actual speed.		0	r/min	0 to 20,000	–
604	Jog Speed	Set the command speed for trial JOG operation (speed control).		300	r/min	0 to 500	–
605	Gain 3 Effective Time	Set effective time of Gain 3 for 3-step gain switching.		0	0.1 ms	0 to 10,000	–
606	Gain 3 Ratio Setting	Set Gain 3 as a multiple of Gain 1.		100	%	50 to 1,000	–
607	Torque Command Value Offset	Set the offset torque to be added to torque commands.		0	%	–100 to 100	–
608	Forward Direction Torque Offset	Set the value to be added to torque commands for operation in the forward direction.		0	%	–100 to 100	–
609	Reverse Direction Torque Offset	Set the value to be added to torque commands for operation in the reverse direction.		0	%	–100 to 100	–
610	Function Expansion Setting	Set the function extension value. The set value varies depending on the function.		0	–	0 to 63	–
611	Electric Current Response Setting	Make fine adjustment to electric current response. The default setting is 100%.		100	%	50 to 100	–
613	Inertia Ratio 2	Set the value for switching the inertia ratio.		250	–	0 to 10,000	–
614	Alarm Detection Allowable Time Setting	Set the allowable time until stopping if an immediate stop is executed when an alarm occurs.		200	ms	0 to 1,000	–
615	Overspeed Detection Level Setting at Immediate Stop	If the motor speed exceeds the set value during an immediate stop due to an alarm, an Overspeed 2 Error will occur.		0	r/min	0 to 20,000	–
616	Reserved	Do not set.		1	–	0	Required
617	Front Panel Parameter Write Selection	Select whether to enable or disable writing to EEPROM when a parameter is changed.		0	–	0 to 1	Required
		0	Writing with parameter changes disabled				
		1	Writing with parameter changes enabled				
618	Power Supply ON Initialization Time	Set the initialization time after turning ON the power supply to the standard 1.5 seconds plus the specified value.		0	0.1 s	0 to 100	Required
619	Encoder Phase-Z Setting	Make fine adjustment to the encoder phase-Z width if the number of pulses per motor rotation after pulse output dividing is not an integer.		0	Pulse	0 to 32,767	Required
620	Reserved	Do not set.		0	–	0	–
621	Reserved	Do not set.		0	–	0	–

Pn No.	Name	Setting	Description	Default setting	Unit	Setting range	Cycle the power supply
622	Reserved	Do not set.		0	–	0	–
623	Disturbance Torque Compensation Gain	Set the compensation gain for the disturbance torque.		0	%	–100 to 100	–
624	Disturbance Observer Filter Setting	Set the filter time constant for disturbance torque compensation.		53	0.01 ms	10 to 2,500	–
627	Warning Latch Hold Time Selection	Select the warning latch time.		5	s	0 to 10	Required
		0	Latch time infinite				
		1 to 10	Latch time 1 to 10 seconds				
628	Not used	Do not change the set value.		–	–	–	–
631	Realtime Autotuning Estimated Speed Selection	Set the speed to estimate the load characteristic while the realtime autotuning is enabled.		1	–	0 to 3	–
		0	Fixes the estimated result when load estimation is stabilized.				
		1	Estimates every minute from the load characteristic changes.				
		2	Estimates every second from the load characteristic changes.				
		3	Estimates the optimum from the load characteristic changes.				
632	Realtime Autotuning Customization Mode Setting	Set the details of the realtime autotuning customization mode.		0	–	–3,2768 to 32,767	–
633	Reserved	Do not set.		1,000	–	1,000	–
634	Reserved	Do not set.		0	–	0	–
635	Reserved	Do not set.		10	–	10	–
637	Vibration Detection Threshold	Set the vibration detection threshold. If torque vibration that exceeds this setting is detected, a vibration detection warning occurs.		0	0.1%	0 to 1,000	–
638	Warning Mask Setting	Set the warning mask to disable detection of a particular warning. If you set the corresponding bit to 1, detection of the corresponding warning detection is disabled.		4	–	–32,768 to 32,767	Required



Precautions for Correct Use

Pn700 to Pn799 and Pn800 to Pn899 are not used. Do not change the settings.

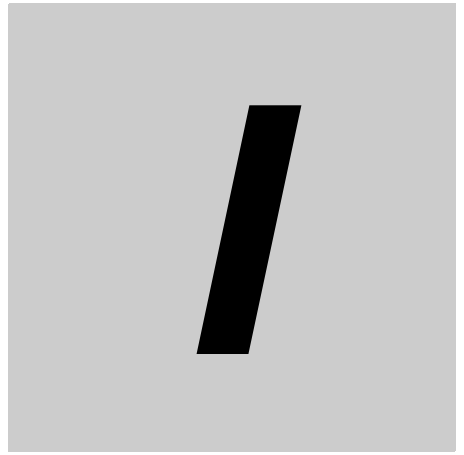

Index



Index

Numerics

1,000-r/min Servomotors	3-50
2,000-r/min Servomotors	2-9, 3-45
3,000-r/min Servomotors	2-8, 3-37

A

Accessories	-13
Actions for Problems	10-2
Adaptive Filter	6-6
Adaptive Filter Selection (Pn200)	7-20
Alarm Clear	8-22
Alarm Clear Attribute Output (ALM-ATB)	3-31
Alarm Detection Allowable Time Setting (Pn614)	7-57
Alarm List	10-7
Alarm Output (/ALM)	3-29
Alarm Reset Condition Setting (Pn516)	7-49
Alarm Reset Input (RESET)	3-21
Allowable current	4-18
Analog Monitor 1 Scale Setting (Pn417)	7-34
Analog Monitor 1 Selection (Pn416)	7-33
Analog Monitor 2 Scale Setting (Pn419)	7-35
Analog Monitor 2 Selection (Pn418)	7-34
Analog Monitor Cable	2-18, 3-83
Analog Monitor Output Setting (Pn421)	7-35
Applicable Standards	1-10

B

Brake Cable Connector	3-82
Brake Cables (Global Flexible Cable)	2-17, 3-79
Brake Cables (Global Non-Flexible Cable)	2-16, 3-78
Brake Interlock	6-18
Brake Interlock Output (BKIR)	3-29
Brake Release Speed Setting (Pn439)	7-41
Brake Timing during Operation (Pn438)	7-40
Brake Timing when Stopped (Pn437)	7-39

C

Cable specifications	3-62
Changing the Mode	8-6
Clamp core	4-29
Combinations of Servomotors and Decelerators	2-40
Command Pulse Input Maximum Setting (Pn532)	7-54
Command Pulse Input Selection (Pn005)	7-4
Command Pulse Mode Selection (Pn007)	7-5
Command Pulse Prohibition Input Read Setting (Pn519)	7-50
Command Pulse Prohibition Input Setting (Pn518)	7-50
Command Pulse Rotation Direction Switching Selection (Pn006)	7-4
Command Speed Selection (Pn300)	7-26

Connection Examples	A-2
Connector specifications	3-62
Connector Terminal Block	2-20
Connector Terminal Block Cables	2-20, 3-91
Connector Terminal Block Conversion Unit	3-93
Connectors	2-18
Contactors	4-33
Control Cables	2-20
Control I/O Connector	3-80
Control I/O Connector Specifications (CN1)	3-9
Control Input Circuits	3-15
Control Input Signal Read Setting (Pn515)	7-49
Control Inputs (CN1)	3-10
Control Mode Selection (Pn001)	7-3
Control Mode Switching (TVSEL)	3-22
Control Output Circuits	3-27
Control Output Sequence	3-28

D

Damping Control	6-3
Damping Filter 1 Setting (Pn215)	7-22
Damping Filter 2 Setting (Pn217)	7-23
Damping Filter 3 Setting (Pn219)	7-23
Damping Filter 4 Setting (Pn221)	7-23
Damping Filter Selection (Pn213)	7-22
Damping Filter Switching 1 (DFSEL1)	3-23
Damping Filter Switching 2 (DFSEL2)	3-23
Damping Frequency 1 (Pn214)	7-22
Damping Frequency 2 (Pn216)	7-22
Damping Frequency 3 (Pn218)	7-23
Damping Frequency 4 (Pn220)	7-23
Decelerator Dimensions	2-42
Decelerator for 1,000-r/min Servomotors (Backlash: 3 Arcminutes max.)	3-59
Decelerator for 2,000-r/min Servomotors (Backlash: 3 Arcminutes max.)	3-57
Decelerator for 3,000-r/min Servomotors (Backlash: 15 Arcminutes max.)	2-54, 3-60
Decelerator for 3,000-r/min Servomotors (Backlash: 3 Arcminutes max.)	2-42, 3-54
Decelerator Installation Conditions	4-6
Decelerator model	2-12
Decelerator Specifications	3-54
Default Display (Pn528)	7-53
Disturbance Observer Filter Setting (Pn624)	7-58
Disturbance Torque Compensation Gain (Pn623)	7-58
Drive Prohibition Input Selection (Pn504)	7-43

E

EC Directives	1-10
Electric Current Response Setting (Pn611)	7-56
Electronic Gear Function	6-11
Electronic Gear Integer Setting (Pn008)	7-7

Electronic Gear Ratio Denominator (Pn010)	7-7
Electronic Gear Ratio Numerator 1 (Pn009)	7-7
Electronic Gear Ratio Numerator 2 (Pn500)	7-42
Electronic Gear Ratio Numerator 3 (Pn501)	7-42
Electronic Gear Ratio Numerator 4 (Pn502)	7-42
Electronic Gear Switching 1 (GESEL1)	3-23
Electronic Gear Switching 2 (GESEL2)	3-23
Emergency Stop Input (STOP)	3-26
Encoder Cables (Global Flexible Cable)	2-17, 3-66
Encoder Cables (Global Non-Flexible Cable)	2-16, 3-64
Encoder Connector Specifications (CN2)	3-32
Encoder Connectors	3-80
Encoder Dividing Denominator (Pn503)	7-42
Encoder Dividing Numerator (Pn011)	7-8
Encoder Output Direction Switching Selection (Pn012)	7-8
Encoder Outputs (Phase A, B and Z)	3-29
Encoder Specifications	3-53
Error Counter Overflow Level (Pn014)	7-8
Error Counter Reset Condition Selection (Pn517)	7-49
Error Counter Reset Input (ECRST)	3-22
Error Diagnosis Using the Operation State	10-17
Error Diagnosis with Alarm Displays	10-10
Excessive Speed Error Setting (Pn602)	7-55
External Dimensions	2-22
External Regeneration Resistor	4-42
External Regeneration Resistor Connector Specifications (CNC)	3-7, 4-15
External Regeneration Resistor Dimensions	2-56
External Regeneration Resistor Setting (Pn017)	7-9
External Regeneration Resistor Specifications	3-122
External Regeneration Resistors	2-20, 4-42

F

Forward Direction Torque Offset (Pn608)	7-55
Forward Drive Prohibition Input (POT)	3-21
Forward External Torque Limit (Pn525)	7-52
Front Panel Parameter Write Selection (Pn617)	7-58
Function Expansion Setting (Pn610)	7-56

G

Gain 3 Effective Time (Pn605)	7-55
Gain 3 Ratio Setting (Pn606)	7-55
Gain Adjustment	9-2
Gain Switching (GSEL)	3-22
Gain Switching Delay Time in Position Control (Pn116)	7-15
Gain Switching Delay Time in Speed Control (Pn121)	7-18
Gain Switching Function	6-23
Gain Switching Hysteresis in Position Control (Pn118)	7-16
Gain Switching Hysteresis in Speed Control (Pn123)	7-19
Gain Switching Input Operating Mode Selection (Pn114)	7-13
Gain Switching Level in Position Control (Pn117)	7-16

Gain Switching Level in Speed Control (Pn122)	7-18
General Servo Drive specifications	3-2
General Servomotor specifications	3-36
General-purpose Control Cables	3-89
General-purpose Control Cables (with connector on one end)	2-20
General-Purpose Input	3-17

H

Harmonic Current Measures	4-36
High-speed Photocoupler Input	3-17

I

Immediate Stop Torque (Pn511)	7-47
Improving Control I/O Signal Noise Resistance	4-35
Improving Encoder Cable Noise Resistance	4-34
Incremental encoder	3-53
Inertia Ratio 1 (Pn004)	7-4
Inertia Ratio 2 (Pn613)	7-56
Inertia Ratio Switching Input (JSEL)	3-26
Input Signal Selection 1 (Pn400)	7-32
Input Signal Selection 2 (Pn401)	7-32
Input Signal Selection 3 (Pn402)	7-32
Input Signal Selection 4 (Pn403)	7-32
Input Signal Selection 5 (Pn404)	7-32
Input Signal Selection 6 (Pn405)	7-32
Input Signal Selection 7 (Pn406)	7-32
Input Signal Selection 8 (Pn407)	7-32
Input Signal Selection 9 (Pn408)	7-32
Input Signal Selection 10 (Pn409)	7-32
Internally Set Speed Control	5-7
Internally Set Speed Selection 1, 2 and 3 (VSEL1, 2 and 3)	3-24

J

Jog Operation	8-23
Jog Speed (Pn604)	7-55

L

Leakage Breaker	4-27
Line Receiver Input	3-19

M

Main Circuit Connector Specifications (CNA)	3-6, 3-7, 4-14, 4-15
Main Circuit Terminal Block Specifications	3-8
Maintenance	10-21
Manual Tuning	9-11
Mode Setting	8-6
Momentary Hold Time (Pn509)	7-46
Monitor Connector Specifications (CN5)	3-33
Monitor Mode	8-7
Motor Connector Specifications (CNB)	3-6, 3-7, 4-14, 4-15

Motor power cable	3-68
Motor Power Cables (Global Flexible Cable)	2-17
Motor Power Cables (Global Non-Flexible Cable)	2-16
Motor Rotation Speed Detection Output (TGON)	3-30
Mounting Brackets	2-21
Mounting Dimensions	2-22

N

Names and Functions	1-4
No. 1 Internally Set Speed (Pn304)	7-27
No. 1 Torque Limit (Pn013)	7-8
No. 2 Internally Set Speed (Pn305)	7-27
No. 2 Torque Limit (Pn522)	7-51
No. 3 Internally Set Speed (Pn306)	7-27
No. 4 Internally Set Speed (Pn307)	7-27
No. 5 Internally Set Speed (Pn308)	7-27
No. 6 Internally Set Speed (Pn309)	7-27
No. 7 Internally Set Speed (Pn310)	7-27
No. 8 Internally Set Speed (Pn311)	7-28
No-fuse Breaker	4-26
Noise Filter for Brake Power Supply	4-24
Noise filters	4-24, 4-29, 4-37
Noise Filters for Motor Output	4-37
Notch 1 Depth Setting (Pn203)	7-20
Notch 1 Frequency Setting (Pn201)	7-20
Notch 1 Width Setting (Pn202)	7-20
Notch 2 Depth Setting (Pn206)	7-21
Notch 2 Frequency Setting (Pn204)	7-20
Notch 2 Width Setting (Pn205)	7-21
Notch 3 Depth Setting (Pn209)	7-21
Notch 3 Frequency Setting (Pn207)	7-21
Notch 3 Width Setting (Pn208)	7-21
Notch 4 Depth Setting (Pn212)	7-21
Notch 4 Frequency Setting (Pn210)	7-21
Notch 4 Width Setting (Pn211)	7-21

O

Operation Command (RUN)	3-21
Operational Procedure	8-2
Output Signal Selection 1 (Pn410)	7-32
Output Signal Selection 2 (Pn411)	7-33
Output Signal Selection 4 (Pn413)	7-33
Overload Detection Level Setting (Pn512)	7-48
Overrun Limit Setting (Pn514)	7-48
Overspeed Detection Level Setting (Pn513)	7-48
Overspeed Detection Level Setting at Immediate Stop (Pn615)	7-57

P

Parameter List	A-11
Parameter Setting Mode	8-19
Parameter Write Mode	8-21
Periodic Maintenance	10-21
Phase-Z Output (Open Collector Output)	3-27
Pin arrangement	3-14
Position Command Filter Time Constant (Pn222)	7-24

Position Command Pulse	3-15
Position Command Status Output (P-CMD)	3-31
Position Control	5-2
Position Control Mode Adjustment	9-12
Position Control Unit Relay Unit Cable Specifications	3-111
Position Feedback Output	3-27
Position Gain Switching Time (Pn119)	7-16
Position Lock Level Setting (Pn316)	7-30
Position Loop Gain (Pn100)	7-10
Position Loop Gain 2 (Pn105)	7-12
Position Setting Unit Selection (Pn520)	7-50
Positioning Completion Condition Selection (Pn432)	7-37
Positioning Completion Output 1 (INP1)	3-30
Positioning Completion Output 2 (INP2)	3-30
Positioning Completion Range 1 (Pn431)	7-37
Positioning Completion Range 2 (Pn442)	7-41
Power Cable Connector	3-82
Power Cables with Brake (Global Flexible Cable)	3-76
Power Cables with Brake (Global Non-Flexible Cable)	3-74
Power Cables without Brake (Global Flexible Cable)	3-71
Power Cables without Brake (Global Non-Flexible Cable)	3-68
Power Supply ON Initialization Time (Pn618)	7-58
Preparing for Operation	8-3
Protective Functions	3-5
Pulse Prohibition Input (IPG)	3-24
Pulse Regeneration Output Limit Setting (Pn533)	7-54

R

Radio noise filter	4-29
Reactor	2-21, 3-124, 4-36
Reactor Dimensions	2-57
Reactor to Reduce Harmonic Current	4-36
Realtime Autotuning	9-4
Realtime Autotuning Customization Mode Setting (Pn632)	7-59
Realtime Autotuning Estimated Speed Selection (Pn631)	7-59
Realtime Autotuning Machine Rigidity Setting (Pn003)	7-4
Realtime Autotuning Mode Selection (Pn002)	7-3
Regeneration Absorption Capacity	4-41
Regeneration Resistor Selection (Pn016)	7-9
Regenerative Energy Absorption	4-39
Replacement procedures	10-4
Replacing the Servo Drive	10-4
Replacing the Servomotor	10-4
Resistance to Bending of Global Flexible Cable	3-62
Reverse Direction Torque Offset (Pn609)	7-55
Reverse Drive Prohibition Input (NOT)	3-21
Reverse External Torque Limit (Pn526)	7-52
Rotation Direction Switching (Pn000)	7-2
Rotation speed characteristics (1,000-r/min Servomotors)	3-52

Rotation speed characteristics (2,000-r/min Servomotors)	3-49
Rotation speed characteristics (3,000-r/min Servomotors)	3-43
Rotation Speed for Motor Rotation Detection (Pn436)	7-39

S

S-curve Acceleration/Deceleration Time Setting (Pn314)	7-28
SEMI F47	1-10
Sequence Output	3-27
Servo Drive and Servomotor combination	2-11
Servo Drive characteristics	3-3
Servo Drive Dimensions	2-22
Servo Drive Functions	1-5
Servo Drive Installation Conditions	4-2
Servo Drive Life Expectancy	10-22
Servo Drive model	2-8
Servo Drive Part Names	1-4
Servo Drive Relay Unit cables	3-108
Servo Ready Completed Output (READY)	3-29
Servo Relay Unit	2-18
Servo Relay Unit Cables (Position Control Unit)	2-19
Servo Relay Unit Cables (Servo Drive)	2-19
Servo Relay Units	3-96
Servomotor	4-3
Servomotor characteristics	3-37
Servomotor Installation Conditions	4-3
Servomotor Life Expectancy	10-21
Servomotor Model	2-8
Smoothing Filter Time Constant (Pn223)	7-25
Soft Start Acceleration Time (Pn312)	7-28
Soft Start Deceleration Time (Pn313)	7-28
Specified Cables for Position Control Unit	3-84
Speed Command Direction Selection (Pn301)	7-26
Speed Command Sign Input (VSIGN)	3-25
Speed Command Status Output (V-CMD)	3-32
Speed Conformity Detection Range (Pn435)	7-38
Speed Conformity Output Signal (VCMP)	3-31
Speed control mode adjustment	9-13
Speed Feedback Filter Time Constant (Pn103)	7-11
Speed Feedback Filter Time Constant 2 (Pn108)	7-12
Speed Feed-forward Amount (Pn110)	7-13
Speed Feed-forward Command Filter (Pn111)	7-13
Speed Loop Gain (Pn101)	7-11
Speed Loop Gain 2 (Pn106)	7-12
Speed Loop Integral Time Constant (Pn102)	7-11
Speed Loop Integral Time Constant 2 (Pn107)	7-12
Stop Selection for Alarm Detection (Pn510)	7-46
Stop Selection for Drive Prohibition Input (Pn505)	7-43
Stop Selection with Main Power Supply OFF (Pn507)	7-45
Stop Selection with Servo OFF (Pn506)	7-44
Surge Absorber	4-28
Surge Suppressors	4-33
Switching Control	5-13
Switching Mode in Position Control (Pn115)	7-14

Switching Mode in Speed Control (Pn120)	7-17
System Block Diagram	1-6
System Configuration	1-3

T

Terminal Block Specifications	4-16
Terminal Block Wiring	4-19
Torque Command Filter Time Constant (Pn104)	7-12
Torque Command Filter Time Constant 2 (Pn109)	7-12
Torque Command Value Offset (Pn607)	7-55
Torque Feed-forward Amount (Pn112)	7-13
Torque Feed-forward Command Filter (Pn113)	7-13
Torque Limit	6-31
Torque Limit Output (TLIMIT)	3-30
Torque Limit Selection (Pn521)	7-51
Torque Limit Switching (TLSEL)	3-26
Torque Limit Switching Setting 1 (Pn523)	7-52
Torque Limit Switching Setting 2 (Pn524)	7-52
Trial Operation	8-28
Troubleshooting	10-10

U

UL and cUL Standards	1-10
Undervoltage Alarm Selection (Pn508)	7-45
USB Connector Specifications (CN7)	3-34

V

Vibration Detection Threshold (Pn637)	7-61
---	------

W

Warning Latch Hold Time Selection (Pn627)	7-59
Warning Mask Setting (Pn638)	7-61
Warning Output 1 (WARN1)	3-31
Warning Output 2 (WARN2)	3-31
Warning Output Selection 1 (Pn440)	7-41
Warning Output Selection 2 (Pn441)	7-41
Wire sizes	4-18
Wiring Conforming to EMC Directives	4-20

Z

Zero Speed Designation (VZERO)	3-25
Zero Speed Designation Selection (Pn315)	7-29
Zero Speed Detection (Pn434)	7-38
Zero Speed Detection Signal (ZSP)	3-30

OMRON Corporation Industrial Automation Company

Tokyo, JAPAN

Contact: www.ia.omron.com

Regional Headquarters

OMRON EUROPE B.V.

Wegalaan 67-69-2132 JD Hoofddorp
The Netherlands

Tel: (31)2356-81-300/Fax: (31)2356-81-388

OMRON ELECTRONICS LLC

One Commerce Drive Schaumburg,
IL 60173-5302 U.S.A.

Tel: (1) 847-843-7900/Fax: (1) 847-843-7787

OMRON ASIA PACIFIC PTE. LTD.

No. 438A Alexandra Road # 05-05/08 (Lobby 2),
Alexandra Technopark,
Singapore 119967

Tel: (65) 6835-3011/Fax: (65) 6835-2711

OMRON (CHINA) CO., LTD.

Room 2211, Bank of China Tower,
200 Yin Cheng Zhong Road,
PuDong New Area, Shanghai, 200120, China

Tel: (86) 21-5037-2222/Fax: (86) 21-5037-2200

Authorized Distributor:

© OMRON Corporation 2012 All Rights Reserved.
In the interest of product improvement,
specifications are subject to change without notice.

Cat. No. I584-E1-02

0812